



TENDER DOCUMENT

**PROPOSED CONSTRUCTION OF GENERATOR HOUSING,
SUPPLY, DELIVERY, INSTALLATION, TESTING,
TRAINING AND COMMISSIONING OF STANDBY
GENERATOR SETS AND RELATED WORKS**

AMREF HEALTH AFRICA IN KENYA

TENDER NO: AMREF/20/11/2024/028

LOT NUMBER FOUR (4)

INTRODUCTION

Amref Health Africa hereinafter referred to as the Client, Employer or Project Manager intends to invite contractors to tender for the proposed construction of generator housing, supply, delivery, installation, testing, training and commissioning of Standby Generator Sets and related works in various health facilities.

Proposed works will comprise the following;

- (a) Electrical works
- (b) Testing, training and commissioning works.

SIGNATURE AND SPECIAL NOTES

Supplied as part of the contract for;

Proposed construction of generator housing, supply, delivery, installation, testing, training and commissioning of Standby Generator Sets and Related Works in various health facilities.

PREPARED & ISSUED BY:

Amref Health Africa
P.O Box 30125 - 00100
Nairobi

The contract for the above-mentioned works entered into on the day of 20 by the undersigned parties, refers to these Bills of Quantities consisting and the Ministry of Works general specification dated 1976, (together with any amendments thereto issued since the date of publication) which shall be read and construed as part of the said contract.

.....

.....

CONTRACTOR

CLIENT

AMREF HEALTH AFRICA

Date:

Date:

SPECIAL NOTES

The contractor is required to check the pages of these Bills of Quantities together with all collections and summaries and should he find any missing or should the contractor be in doubt of the precise meaning of any items of figures, for any reason whatsoever, he must inform the PROJECT MANAGER in order that the correct meaning may be decided before the date for submission of Tenders.

No liability will be admitted or claim allowed in respect of errors in the contractor's tender due to mistakes in the Bills of Quantities which should have been rectified in the manner described above.

The Bills of Quantities and General Specifications shall be read and construed together and wherever descriptions in the Bills of Quantities do not agree with descriptions in the General Specifications, then the Bills of Quantities shall override.

In the event of any discrepancies arising between the Bills of Quantities and actual works the site measurements shall generally take precedence. However, such discrepancies between any contract documents shall immediately be referred to the PROJECT MANAGER in accordance with Clause 22 of the conditions of Contract. The discrepancies shall then be treated as a variation and be dealt with in accordance with Clause 22 of the said Conditions.

TABLE OF CONTENTS

PART A: TECHNICAL REQUIREMENTS	1
SECTION I: Invitation to Tender	1
SECTION II: Instructions to Tenderers	4
SECTION III: Tender Evaluation Criteria	13
STAGE 1: Preliminary Evaluation	13
STAGE 2: Technical Evaluation	15
STAGE 3: Financial Evaluation	19
(a) Determination of Arithmetic Errors	19
(b) Comparison of rates	19
(c) Consistency of the Rates	19
STAGE 4: Due Diligence	20
SECTION IV: Conditions of Contract	21
SECTION V: Appendix to Conditions of Contract	37
SECTION VI: Standard Forms	39
Form of Invitation for Tenders	40
Form of Tender	41
Letter of Award	42
Form of Agreement	44
Form of Tender Security	46
Qualification Information	48
Confidential Business Questionnaire	51
Part 1 - General	51
Part 2 (a) – Individuals	51
Part 2 (b) – Partnership	51
Part 2 (c) – Registered Company	51
Details of Sub-Contractors	53
Declaration	54
PART B: FINANCIAL	70

PART A: TECHNICAL REQUIREMENTS

SECTION I: Invitation to Tender

1. Amref Health Africa invites sealed bids from eligible candidates for the proposed supply, delivery, installation, testing, training and commissioning of Standby Generator Sets and related works in various health facilities in Kenya in lots as listed below;

Table 1:

LOT	DESCRIPTION	DELIVERY LOCATION
Lot 1.	Construction of generator housing, supply, delivery, installation, testing, training and commissioning of 110 \pm 5 kVA Standby Generator Sets and related works	Banisa Sub County Hospital
		Faza Sub County Hospital
		Mpeketoni Sub County Hospital
		Ngao Sub District Hospital
		Bura Sub County Hospital
		Chemolingot Sub County Hospital
		Daadab Sub County Hospital
		Kabartonjo Sub County Hospital
		Kacheliba Sub County Hospital
		Kalacha Sub County Referral Hospital
		Lokitaung Sub County hospital
		Lokori Sub County Hospital
		Lunga Lunga Sub County Hospital
		Rumuruti Sub County Hospital
Suguta Marmar Sub County Hospital		
Wamba Health Centre		
Lot 2	Construction of generator housing, supply, delivery, installation, testing, training and commissioning of 165 \pm 5 kVA Standby Generator Sets and related works	Habaswein Sub County Hospital
		Ijara Subcounty Hospital
Lot 3	Construction of generator housing, supply, delivery, installation, testing, training and commissioning of 200 \pm 5 kVA Standby Generator Sets and related works	Kapenguria CRH
Lot 4	Electrical Installation Works as specified in the tender document	Elwak District hospital
		Mandera County Hospital
		Sololo Sub County Hospital

2. This tender document is only for **Lot Number Four (4)**.

3. Interested eligible bidders may obtain further information from the **Amref Health Africa website** www.amref.org
4. Complete sets of tender documents can be downloaded from Amref Health Africa website; <http://amref.org/tenders/> by interested bidders upon payment of non-refundable fee of **Ksh.2000 PER LOT**. The payment should be made through the following Bank account(s): **Kenya Commercial Bank, Kipande House Branch, Account No: 1111429243 OR National Bank of Kenya, Wilson Branch, Account No: 01020058235400** or via **MPesa Paybill: 890750, Account: AMREF/20/11/2024/028**.
5. Candidates will then attach the copy of the mobile money receipt or the original banking/deposit slip to the tender documents as proof of purchase. Candidates interested in buying more than one lot **Must** pay for the lots separately and then attach the copy of the mobile money receipts or original banking deposit slips respectively to the tender documents as proof of purchase.
6. Completed tender documents for preliminary, technical requirements and filled BOQ are to be enclosed in a plain envelope marked with the tender reference number and tender name. **Please note that only one complete tender document per lot is required (Do not provide additional copies per lot).**
7. Tenders must be delivered to the address below not later than **Wednesday 04th December 2024 at 12.00 noon** and must be accompanied by a tender security of **Kshs 253,290.00** in the Currency specified in the tender document in the form of a bank guarantee from a reputable bank and must be delivered with the Tender Documents in the technical bid, **(bid bonds from insurance companies will NOT be accepted)**. The tender security validity period from date of closing tender should also be indicated.
8. Tenders should be dropped at the Amref Health Africa Kenya Country Office Tender Box at the Main Reception. Tenders will be opened at 12 noon on the closing date in the presence of the Tenderers' representatives who choose to attend at the Amref Health Africa Kenya Country Office. Electronic bidding will not be permitted. No bids will be accepted after 12 noon on the closing day.
9. Prices quoted should be inclusive of VAT and all other applicable taxes and must be in Kenya Shillings and shall remain valid for 90 days from the closing date of the tender.

NOTE: Global Fund grants are tax exempt. Bidders will be required to submit quotations inclusive of 16% VAT. Payment(s) to the successful bidder(s) shall be made in total exclusive of VAT and tax exemption certificate will be issued accordingly. Successful applicants shall be required to submit proforma invoice and valid tax compliance certificate upon receipt of LPO for processing of specific VAT exemption certificate.

10. Pre-Bid Conference

Interested eligible bidders are also invited for a pre-bid conference to be on **Monday 25th November 2024** starting at **10:00 am**. To access the Link for registration for the pre-bid conference, log onto Amref Health Africa website <http://amref.org/tenders/>

11. Specific Instructions

- 11.1** Bidders must quote for all items and quantities as indicated per Lot in order to qualify for evaluation.

- 11.2** The final bound tender document must be serially paginated (All pages in the document from top page (immediately after top cover) to the last page (one before back cover) including table of content, separators, brochures, bank deposit slip and any other attachments) in a continuous ascending order from the first page to the last in this format; 1,2,3.....n where n indicates the last numerical page number.

- 11.3** Bids will be evaluated on Lot-by-Lot basis.

Amref Health Africa reserves the right to accept or reject any or all bids and is not bound to give reasons for its decision.

SECTION II: Instructions to Tenderers

1. General/Eligibility/Qualifications/Joint venture/Cost of tendering.
 - 1.1 The Employer as defined in the Appendix to Conditions of Contract invites tenders for Works Contract as described in the tender documents. The successful tenderer will be expected to complete the Works by the Intended Completion Date specified in the tender documents.
 - 1.2 All tenderers shall provide the Qualification Information, a statement that the tenderer (including all members of a joint venture and subcontractors) is not associated, or has not been associated in the past, directly or indirectly, with the Consultant or any other entity that has prepared the design, specifications, and other documents for the project or being proposed as Project Manager for the Contract. A firm that has been engaged by the Employer to provide consulting services for the preparation or supervision of the Works, and any of its affiliates, shall not be eligible to tender.
 - 1.3 All tenderers shall provide in the Form of Tender and Qualification Information, a preliminary description of the proposed work method and schedule as necessary.
 - 1.4 In the event that pre-qualification of potential tenderers has been undertaken, only tenders from pre-qualified tenderers will be considered for award of Contract. These qualified tenderers should submit with their tenders any information updating their original pre-qualification applications or, alternatively, confirm in their tenders that the originally submitted pre-qualification information remains essentially correct as of the date of tender submission.
 - 1.5 Where no pre-qualification of potential tenderers has been done, all tenderers shall include the following information and documents with their tenders, unless otherwise stated:
 - a) copies of original documents defining the constitution or legal status, place of registration, and principal place of business; written power of attorney of the signatory of the tender to commit the tenderer.
 - b) total monetary value of construction work performed for each of the last five years;
 - c) experience in works of a similar nature and size for each of the last five years, and details of work under way or contractually committed; and names and addresses of clients who may be contacted for further information on these contracts;
 - d) major items of construction equipment proposed to carry out the Contract and an undertaking that they will be available for the Contract.
 - e) qualifications and experience of key site management and technical personnel proposed for the Contract and an undertaking that they shall be available for the Contract.
 - f) reports on the financial standing of the tenderer, such as profit and loss statements and auditor's reports for the past two years;
 - g) evidence of adequacy of working capital for this Contract (access to line(s) of credit and availability of other financial resources);
 - h) authority to seek references from the tenderer's bankers;
 - i) information regarding any litigation, current or during the last five years, in which the tenderer is involved, the parties concerned and disputed amount; and

- j) proposals for subcontracting components of the Works amounting to more than 10 percent of the Contract Price.

1.6 Tenders submitted by a joint venture of two or more firms as partners shall comply with the following requirements, unless otherwise stated:

- a) Provide a Joint Venture Agreement. A legally binding agreement must be submitted outlining the roles, responsibilities, and contributions of each party.
- b) Provide proof of registration for the Joint Venture or Special Purpose Vehicle.
- a) the tender shall include all the information listed in clause 1.5 above for each joint venture partner;
- b) the tender shall be signed so as to be legally binding on all partners;
- c) all partners shall be jointly and severally liable for the execution of the Contract in accordance with the Contract terms;
- d) one of the partners will be nominated as being in charge, authorized to incur liabilities, and receive instructions for and on behalf of all partners of the joint venture; and
- e) the execution of the entire Contract, including payment, shall be done exclusively with the partner in charge.

1.7 To qualify for award of the Contract, tenderers shall meet the following minimum qualifying criteria;

- a) annual volume of construction work of at least 2.5 times the estimated annual cash flow for the Contract;
- b) experience as main contractor in the construction of at least two completed works of a nature and complexity equivalent to the Works over the last 5 years;
- c) proposals for the timely acquisition (own, lease, hire, etc.) of the essential equipment listed as required for the Works;
- d) a team lead with at least seven years' experience in works of an equivalent nature and volume and;
- e) liquid assets and/or credit facilities, net of other contractual commitments and exclusive of any advance payments which may be made under the Contract, of no less than 4 months of the payment flow under this Contract.

1.8 The figures for each of the partners of a joint venture shall be added together to determine the tenderer's compliance with the minimum qualifying criteria of clause 1.7 (a) and (e); however, for a joint venture to qualify, each of its partners must meet at least 25 percent of minimum criteria 1.7 (a), (b) and (e) for an individual tenderer, and the partner in charge at least 40 percent of those minimum criteria. Failure to comply with this requirement will result in rejection of the joint venture's tender. Subcontractors' experience and resources will not be considered in determining the tenderer's compliance with the qualifying criteria, unless otherwise stated.

1.9 Each tenderer shall submit only one tender, either individually or as a partner in a joint venture. A

tenderer who submits or participates in more than one tender (other than as a subcontractor or in cases of alternatives that have been permitted or requested) will cause all the proposals with the tenderer's participation to be disqualified.

- 1.10 The tenderer shall bear all costs associated with the preparation and submission of his tender, and the Employer will in no case be responsible or liable for those costs.
- 1.11 The tenderer, at the tenderer's own responsibility and risk, is encouraged to visit and examine the Site of the Works and its surroundings, and obtain all information that may be necessary for preparing the tender and entering into a contract for construction of the Works. The costs of visiting the Site shall be at the tenderer's own expense.
- 1.12 The procuring entity's employees, committee members, board members and their relative (spouse and children) are not eligible to participate in the tender.
- 1.13 The price to be charged for the tender document shall be **Kshs. 2,000.00/= Per Lot**.
- 1.14 The procuring entity shall allow the tenderer to review the tender document free of charge before purchase through the website.

2. Tender Documents

- 2.1 The complete set of tender documents comprises the documents listed below and any addenda issued in accordance with Clause 2.4.
 - a) These Instructions to Tenderers
 - b) Form of Tender and Qualification Information
 - c) Conditions of Contract
 - d) Appendix to Conditions of Contract
 - e) Specifications
 - f) Bills of Quantities
 - g) Forms of Securities
- 2.2 The tenderer shall examine all Instructions, Forms to be filled and Specifications in the tender documents. Failure to furnish all information required by the tender documents, or submission of a tender not substantially responsive to the tendering documents in every respect will be at the tenderer's risk and may result in rejection of his tender.
- 2.3 Enquiries from prospective tenderers shall be addressed during the Pre-bid conference to be held on **Monday 25th November 2024**.
- 2.4 Before the deadline for submission of tenders, the Employer may modify the tendering documents by issuing an addendum. Any addendum thus issued shall be part of the tendering documents and shall be communicated in writing or email to all tenderers. Prospective tenderers shall acknowledge receipt of each addendum in writing to the Employer.
- 2.5 To give prospective tenderers reasonable time in which to take an addendum into account in preparing their tenders, the Employer shall extend, as necessary, the deadline for submission of tenders, in accordance with Clause 4.2 here below.

3. Preparation of Tenders

- 3.1 All documents relating to the tender and any correspondence shall be in English language.

- 3.2 The final bound tender document must be serially paginated (All pages in the document from top page (immediately after top cover) to the last page (one before back cover) including table of content, separators, brochures, bank deposit slip and any other attachments) in a continuous ascending order from the first page to the last in this format; 1,2,3.....n where n is the last numerical page number.
- 3.3 The document should be clearly arranged with separators and bound.
- 3.4 The tender submitted by the tenderer shall comprise the following:
- (a) These Instructions to Tenderers, Form of Tender, Conditions of Contract,
 - (b) Appendix to Conditions of Contract and Specifications;
 - (c) Tender Security;
 - (d) Priced Bill of Quantities;
 - (e) Qualification Information Form and Documents;
 - (f) Alternative offers where invited; and
 - (g) Any other materials required to be completed and submitted by the tenderers.
- 3.5 The tenderer shall fill in rates and prices for all items of the Works described in the Bill of Quantities. Items for which no rate or price is entered by the tenderer will not be paid for when executed and shall be deemed covered by the other rates and prices in the Bill of Quantities. All duties, taxes, and other levies payable by the Contractor under the Contract, or for any other cause relevant to the Contract, as of 30 days prior to the deadline for submission of tenders, shall be included in the tender price submitted by the tenderer.
- 3.6 The rates and prices quoted by the tenderer shall only be subject to adjustment during the performance of the Contract if provided for in the Appendix to Conditions of Contract and provisions made in the Conditions of Contract.
- 3.7 The unit rates and prices shall be in Kenya Shillings.
- 3.8 Tenders shall remain valid for a period of Ninety (90) from the date of submission. However, in exceptional circumstances, the Employer may request that the tenderers extend the period of validity for a specified additional period. The request and the tenderers' responses shall be made in writing. A tenderer may refuse the request without forfeiting the Tender Security. A tenderer agreeing to the request will not be required or permitted to otherwise modify the tender, but will be required to extend the validity of Tender Security for the period of the extension, and in compliance with Clause 3.9 to 3.13 in all respects.
- 3.9 The tenderer shall furnish, as part of the tender, a Tender Security in the amount and form specified in the appendix to invitation to tenderers. This shall be in the amount specified in this tender document.
- 3.10 The format of the Tender Security should be in accordance with the form of Tender Security included in Section V - Standard forms or any other form acceptable to the Employer. Tender Security shall be valid for 90 days beyond the validity of the tender.
- 3.11 Any tender not accompanied by an acceptable Tender Security shall be rejected. The Tender Security of a joint venture must define as "Tenderer" all joint venture partners and list them in the following manner: a joint venture consisting of "....."
".....", and ".....".

3.12 The Tender Securities of unsuccessful tenderers will be returned within 28 days of the end of the tender validity period specified in Clause 3.8.

3.13 The Tender Security of the successful tenderer will be discharged when the tenderer has signed the Contract Agreement and furnished the required Performance Security.

3.14 The Tender Security may be forfeited

- (a) if the tenderer withdraws the tender after tender opening during the period of tender validity;
- (b) if the tenderer does not accept the correction of the tender price, pursuant to Clause 5.7;
- (c) in the case of a successful tenderer, if the tenderer fails within the specified time limit to;
 - (i) sign agreement, or
 - (ii) furnish the required Performance Security

3.15 Tenderers shall submit offers that comply with the requirements of the tendering documents, including the basic technical design as indicated in the Specifications. Alternatives will not be considered, unless specifically allowed in the invitation to tender. If so allowed, tenderers wishing to offer technical alternatives to the requirements of the tendering documents must also submit a tender that complies with the requirements of the tendering documents, including the basic technical design as indicated in the Specifications. In addition to submitting the basic tender, the tenderer shall provide all information necessary for a complete evaluation of the alternative, including design calculations, technical specifications, breakdown of prices, proposed construction methods and other relevant details. Only the technical alternatives, if any, of the lowest evaluated tender conforming to the basic technical requirements shall be considered.

3.16 The tenderer shall only submit one completed tender document per lot as described in Clause 3.4 of these Instructions to Tenderers, and containing the Form of Tender, and **clearly marked with the tender reference number and tender name**. (Do not provide additional copies per lot).

3.17 The submitted tender shall be typed or written in indelible ink and shall be signed by a person or persons duly authorised to sign on behalf of the tenderer, pursuant to Clause 1.5 (a) or 1.6 (b), as the case may be. All pages of the tender where alterations or additions have been made shall be initialled by the person or persons signing the tender.

3.18 Clarification of tenders shall be made during the Pre-bid conference to be held on **Monday 25th November 2024**.

3.19 The tender security shall be in the amount of **KShs 253,290.00**.

4. Submission of Tenders.

4.1 The tenderer shall seal the original of the tender in one envelope, duly marked. The envelope shall:

- (a) be addressed to the Employer at the address provided in the invitation to tender;
- (b) bear the tender name and tender reference number of the Contract as defined in the invitation to tender; and

(c) provide a warning not to open before the specified time and date for tender opening.

4.2 Tenders shall be delivered to the Employer at the address specified above not later than the time and date specified in the invitation to tender. However, the Employer may extend the deadline for submission of tenders by issuing an amendment in accordance with Sub-Clause 2.5 in which case all rights and obligations of the Employer and the tenderers previously subject to the original deadline will then be subject to the new deadline.

4.3 Any tender received after the deadline prescribed in clause 4.2 will be returned to the tenderer unopened.

4.4 Tenderers may modify or withdraw their tenders by giving notice in writing before the deadline prescribed in clause 4.2. Each tenderer's modification or withdrawal notice shall be prepared, sealed, marked, and delivered in accordance with clause 3.15 and 4.1, with the outer and inner envelopes additionally marked "MODIFICATION" and "WITHDRAWAL", as appropriate. No tender may be modified after the deadline for submission of tenders.

4.5 Withdrawal of a tender between the deadline for submission of tenders and the expiration of the period of tender validity specified in the invitation to tender or as extended pursuant to Clause 3.8 may result in the forfeiture of the Tender Security pursuant to Clause 3.13.

4.6 Tenderers may only offer discounts to, or otherwise modify the prices of their tenders by submitting tender modifications in accordance with Clause 4.4 or be included in the original tender submission.

5. Tender Opening and Evaluation

5.1 The tenders will be opened by the Employer, including modifications made pursuant to Clause 4.4, in the presence of the tenderers' representatives who choose to attend at the time and in the place specified in the invitation to tender. Envelopes marked "WITHDRAWAL" shall be opened and read out first. Tenderers' and Employer's representatives who are present during the opening shall sign a register evidencing their attendance.

5.2 The tenderers' names and proof of purchase of each tender and any alternative tender (if alternatives have been requested or permitted), tender modifications and withdrawals, and such other details as may the Employer, at its discretion may consider appropriate will be announced at the opening. The Employer shall prepare a tender opening report.

5.3 Information relating to the examination, clarification, evaluation, and comparison of tenders and recommendations for the award of Contract shall not be disclosed to tenderers or any other third parties out of the context of the evaluation committee until the award to the successful tenderer has been announced. Any effort by a tenderer to influence the Employer's officials, processing of tenders or award decisions shall result in the rejection of his tender.

5.4 To assist in the examination, evaluation, and comparison of tenders, the Employer at his discretion, may ask any tenderer for clarification of the tender, including breakdowns of unit rates. The request for clarification and the response shall be in writing or email but no change in the price or substance of the tender shall be sought, offered, or permitted except as required to confirm the correction of arithmetic errors discovered in the evaluation of the tenders in accordance with Clause 5.7.

5.5 Prior to the detailed evaluation of tenders, the Employer will determine whether each tender (a) meets the eligibility criteria defined in Clause 1.7; (b) has been properly signed; (c) is accompanied by the required securities; and (d) is substantially responsive to the requirements of the tendering

documents. A substantially responsive tender is one which conforms to all the terms, conditions and specifications of the tendering documents, without material deviation or reservation. A material deviation or reservation is one (a) which affects in any substantial way the scope, quality, or performance of the works; (b) which limits in any substantial way, inconsistent with the tendering documents, the Employer's rights or the tenderer's obligations under the Contract; or (c) whose rectification would affect unfairly the competitive position of other tenderers presenting substantially responsive tenders.

5.6 If a tender is not substantially responsive, it will be rejected, and may not subsequently be made responsive by correction or withdrawal of the nonconforming deviation or reservation.

5.7 Tenders determined to be substantially responsive will be checked for any arithmetic errors. Errors will be corrected as follows:

- (a) where there is a discrepancy between the amount in figures and the amount in words, the amount in words will prevail; and
- (b) where there is a discrepancy between the unit rate and the line item total resulting from multiplying the unit rate by the quantity, the unit rate as quoted will prevail, unless in the opinion of the Employer, there is an obvious typographical error, in which case the adjustment will be made to the entry containing that error.
- (c) In the event of a discrepancy between the tender amount as stated in the Form of Tender and the corrected tender figure in the main summary of the Bill of Quantities, the amount as stated in the Form of Tender shall prevail.
- (d) The Error Correction Factor shall be computed by expressing the difference between the tender amount and the corrected tender sum as a percentage of the corrected Work (i.e. Corrected tender sum less Prime Cost and Provisional Sums).
- (e) The Error Correction Factor shall be applied to all Works (as a rebate or addition as the case may be) for the purposes of valuations for Interim Certificates and valuation of variations.
- (f) the amount stated in the tender will be adjusted in accordance with the above procedure for the correction of errors and, with concurrence of the tenderer, shall be considered as binding upon the tenderer. If the tenderer does not accept the corrected amount, the tender may be rejected and the Tender Security may be forfeited in accordance with clause 3.13.

5.8 The Employer will evaluate and compare only the tenders determined to be substantially responsive in accordance with Clause 5.5.

5.9 In evaluating the tenders, the Employer will determine for each tender the evaluated tender price by adjusting the tender price as follows:

- (a) making any correction for errors pursuant to clause 5.7;
- (b) excluding provisional sums and the provision, if any, for contingencies in the Bill of Quantities, but including Dayworks where priced competitively.

- (c) making an appropriate adjustment for any other acceptable variations, deviations, or alternative offers submitted in accordance with clause 3.14; and
- (d) making appropriate adjustments to reflect discounts or other price modifications offered in accordance with clause 4.6.

5.10 The Employer reserves the right to accept or reject any variation, deviation, or alternative offer. Variations, deviations, and alternative offers and other factors which are in excess of the requirements of the tender documents or otherwise result in unsolicited benefits for the Employer will not be taken into account in tender evaluation.

5.11 The tenderer shall not influence the Employer on any matter relating to his tender from the time of the tender opening to the time the Contract is awarded. Any effort by the Tenderer to influence the Employer or his employees in his decision on tender evaluation, tender comparison or Contract award may result in the rejection of the tender.

5.12 Firms incorporated in Kenya where indigenous Kenyans own 51% or more of the share capital shall be allowed a 10% preferential bias provided that they do not sub-contract work valued at more than 50% of the Contract Price excluding Provisional Sums to a non-indigenous sub-contractor.

6. Award of Contract

6.1 Subject to Clause 6.2, the award of the Contract will be made to the tenderer whose tender has been determined to be substantially responsive to the tendering documents and who has offered the lowest evaluated tender price, provided that such tenderer has been determined to be (a) eligible in accordance with the provision of Clauses 1.2, and (b) qualified in accordance with the provisions of clause 1.7 and 1.8.

6.2 Notwithstanding clause 6.1 above, the Employer reserves the right to accept or reject any tender, and to cancel the tendering process and reject all tenders, at any time prior to the award of Contract, without thereby incurring any liability to the affected tenderer or tenderers or any obligation to inform the affected tenderer or tenderers of the grounds for the action.

6.3 The tenderer whose tender has been accepted will be notified of the award prior to expiration of the tender validity period in writing or email. This notification (hereinafter and in all Contract documents called the "Letter of Acceptance") will state the sum (hereinafter and in all Contract documents called the "Contract Price") that the Employer will pay the Contractor in consideration of the execution, completion, and maintenance of the Works by the Contractor as prescribed by the Contract. At the same time the other tenderers shall be informed that their tenders have not been successful. The contract shall be formed on the parties signing the contract.

6.4 The Agreement will incorporate all agreements between the Employer and the successful tenderer.

6.5 The LPO together with the contract will be sent to the successful tenderer if they acknowledge receipt and acceptance of the offer within 5 days following the date of notification of award. After receipt of the Letter of Acceptance, the successful tenderer shall deliver to the Employer a Performance Security in the amount stipulated in the Appendix to Conditions of Contract and in the form stipulated in the Tender documents. The Performance Security shall be in the amount and specified form.

6.6 Failure of the successful tenderer to comply with the requirements of clause 6.5 shall constitute sufficient grounds for cancellation of the award and forfeiture of the Tender Security.

- 6.7 Preference where allowed in the evaluation of tenders shall not be allowed for contracts not exceeding one year (12 months).
- 6.8 The tender evaluation shall be carried out within a maximum of 30 calendar days from the day of opening the tender.
- 6.9 The parties to the contract shall have it signed within 30 days from the date of notification of contract award unless there is an administrative review request.
- 6.10 Contract price variations shall not be allowed for contracts not exceeding one year (12 months).
- 6.11 Where contract price variation is allowed, the valuation shall not exceed 15% of the original contract price.
- 6.12 Price variation request shall be processed by the procuring entity within 14 days of receiving the request.
- 6.13 The procuring entity may at any time terminate procurement proceedings before contract award and shall not be liable to any person for the termination.
- 6.14 The procuring entity shall give prompt notice of the termination to the tenderers and on request give its reasons for termination within 14 days of receiving the request from any tenderer.
- 6.15 A tenderer who gives false information in the tender document about its qualification or who refuses to enter into a contract after notification of contract award shall be considered for debarment from participating in future public procurement.

7. Corrupt and Fraudulent practices

- 7.1 The procuring entity requires that tenderers observe the highest standards of ethics during procurement process and execution of contracts. A tenderer shall sign a declaration that he has not and will not be involved in corrupt and fraudulent practices.

8. Appeal Period

- 8.1 Any vendor/service provider who wishes to appeal against the outcome of the tender shall do so in writing within 3 working days of the date of the notification/regret letter. Any letter received after the third day shall not be responded to and shall be treated as null and void. Amref Health Africa shall have dispensed with this procurement.

SECTION III: Tender Evaluation Criteria

After tender opening, the tenders will be evaluated in 4 stages, namely:

1. Preliminary Evaluation
2. Technical Evaluation – 1st Stage
3. Technical Evaluation – 2nd Stage
4. Financial Evaluation
5. Due diligence

STAGE 1: Preliminary Evaluation

Bids will be evaluated based on the below criteria and the bids **lacking any of the documents** below will be considered as non-responsive and therefore will be eliminated at this stage.

Table 2:

PRELIMINARY EVALUATION OF MANDATORY REQUIREMENTS				
Mandatory Requirements				
No.	Particulars	Marks	Compliant	Non-compliant
1.	Copy of Certificate of Incorporation/Certificate of Registration. <i>(For Joint Ventures, provide relevant copies for all entities involved)</i>	1 or 0		
2.	Copy of valid KRA Tax Compliance certificate <i>(For Joint Ventures, provide relevant copies for all entities involved)</i>	1 or 0		
3.	Copy of CR12 generated within the last 12 months (not older than October 2023) <i>(For Joint Ventures, provide relevant copies for all entities involved)</i>	1 or 0		
4.	Must attach Mobile money deposit receipt/ banking deposit slip as proof of purchase of tender documents	1 or 0		
5.	Must provide a copy of Valid business Trading License <i>(For Joint Ventures, provide relevant copies for all entities involved)</i>	1 or 0		
6.	Must provide Manufacturer’s certificate (if bidding as the manufacturer) or Manufacturer’s authorization (if not the manufacturer) for the I. Main Distribution panel II. 3-Phase Automatic voltage regulator (AVR)	1 or 0		
7.	Must provide tender security from a reputable bank amounting to Kshs 253,290.00 valid up to Monday 02nd June 2025 <i>(For Joint Ventures, the Tender Security must define as “Tenderer” all joint venture partners and list them in the following manner: a joint venture consisting of “.....”, and “.....”.)</i>	1 or 0		
8.	Must submit copies of 2 most recent sequential audited financial reports (from 2021) and each must be signed and dated by the auditor and the firms Directors. (Both reports must have unqualified/unmodified auditor’s opinion). <i>(For Joint Ventures, provide relevant copies for all entities involved)</i>	1 or 0		

9.	<p>Energy and Petroleum Regulatory Authority (EPRA) valid license for Electrical contractors; (Class B and above).</p> <p>NOTE:</p> <ul style="list-style-type: none"> • <i>For Joint Ventures, any of the entities can be mentioned in the EPRA License as per their joint venture agreement</i> <p><i>For sub-contractors, the EPRA License should correspond to the electrical works and must be accompanied by a <u>signed and witnessed</u> sub-contractor agreement between the two parties</i></p>	1 or 0		
10.	<p>ENSURE that all pages are sequentially paginated in the format 1, 2,3 starting with 1 on top page (<i>see details of pagination and binding on section 11.2 of the tender document</i>).</p>	1 or 0		

Note:

- 1. All the above documents numbered 1 to 10 should be packaged and arranged in that order under the preliminary evaluation criteria section of the tender document.**
- 2. For joint ventures, the joint venture agreement must be provided and detail the responsibilities of each of the partners as per the requirements in section 1.6. Failure to meet the requirements as per section 1.6 will lead to automatic disqualification**

STAGE 2: Technical Evaluation

The tender document shall be examined based on clause 2.2 of the Instruction to Tenderers which states as follows:

1. In accordance with clause 2.2 of Instruction to Tenderers, the tenderers will be required to provide evidence for eligibility of the award of the tender by satisfying the employer of their eligibility under sub clause 2.1 of Instructions to Tenderers and their capability and adequacy of resources to effectively carry out the subject contract.
2. In order to comply with provisions of clause 2.2 of Instruction to Tenderers, the tenderers shall be required;
 - a) To fill the Standard Forms provided in the bid document for the purposes of providing the required information. The tenderers may also attach the required information if they so desire;
 - b) To supply equipment/items which comply with the technical specifications set out in the bid document. In this regard, the bidders shall be required to submit relevant technical brochures/catalogues with the tender document, highlighting the Catalogue Numbers of the proposed items. Such brochures/catalogues should indicate comprehensive relevant data of the proposed equipment/items which should include but not limited to the following:
 - (i) Standards of manufacture;
 - (ii) Performance ratings/characteristics;
 - (iii) Material of manufacture;
 - (iv) Electrical power ratings;
 - (v) Proof of CE Certification of the product; and
 - (vi) Any other necessary requirements (Specify)
 - (vii) Equipment compatibility restrictions with the rest of the electrical system/Installation.

The bid will then be analysed, using the information in the technical brochures, to determine compliance with General and Particular technical specifications for the works as indicated in the tender document.

The tenderer shall also fill in the Technical Schedule as specified in the tender document for Equipment and Items indicating the Country of Origin, Model/Make/Manufacturer and catalogue numbers of the Items/Equipment they propose to supply.

Only bidders who shall meet the mandatory requirement of the 1st stage of the technical evaluation shall proceed to the 2nd stage of technical evaluation.

Table 3: Technical Evaluation

Requirements			
PART A			
Compliance with Technical Specifications for the following key components;			
	<u>Description of requirements</u>		Max Score
1	Electrical works		
1.1	Distribution Panel (Specify Make and Model) Factory made and factory assembled Outdoor Electrical power Distribution Panel	Must Attach product data sheet/manual/brochure from the manufacturer/panel builder to evidence the distribution panel compliance with IEC 61439 or KS IEC 61439 (for local manufacturer's)	10 or 0 Marks
1.2	Cables and Cable handling materials		
	- PVC-insulated, armoured, and non-armoured cables	<ul style="list-style-type: none"> - Must Attach technical product data sheet/manual/brochure from the manufacturer. - Provide a valid ISO 9001 certificate or equivalent from an accredited certifying body for the manufacture of the listed electrical power cables - Provide proof of conformance to KS 6346 or equivalent 	5 or 0 Marks
1.3	3-Phase Automatic voltage regulator (AVR)	<ul style="list-style-type: none"> - Must Attach product data sheet/manual/brochure from the manufacturer. to evidence the AVR specifications - Provide a valid ISO 9001 certificate or equivalent from an accredited certifying body for the manufacture of the listed AVR 	6 or 0 Marks
2	Key Personnel – Electrical Works	<p>Technical Personnel: Provide CVs of technical personnel and their academic and professional certificates for;</p> <p>1(a) At least 1-degree /higher diploma holder of key personnel in electrical engineering field. <i>(Should be post-education experience)</i></p> <ul style="list-style-type: none"> i. With over 7 years relevant experience-----3 Marks ii. With 5 to 7 years relevant experience-----2 Marks iii. With under 5 years relevant experience-----1 Mark iv. No relevant certificate-----0 Mark 	3 Marks

		<p>1(b) At least 2 diploma holders of key personnel in electrical engineering field. <i>(Should be post-education experience)</i></p> <p>i. With over 5 years relevant experience-----2 Marks Each</p> <p>ii. With 2 to 5 years relevant experience-----1 Marks Each</p> <p>iii. With under 2 years relevant experience or no relevant experience-----0 Mark</p>	4 Marks
		<p>1(c) At least 2 artisans (certificate holder electrical engineering field.) <i>(Should be post-education experience)</i></p> <p>i. Artisan with over 2 years relevant experience---2 Marks Each</p> <p>ii. Artisan with over 1 year but less than 2 years relevant experience----1 Mark Each</p> <p>iii. With Under 1 years' experience or no artisan-----0 Marks</p>	4 Marks
3	Annual Turnover (2 most recent audited financial reports from 2021);	<p>i. Average Annual Turn-over equal or greater than the cost of the project. (4 marks)</p> <p>ii. Average Annual Turn-over above 50% but below 100% of the cost of the project - (2 marks)</p> <p>iii. Average Annual Turn-over below 50% of the cost of the project (1 mark)</p>	4 Marks
4	Contractors Equipment	Provide list of at least five (5) key equipment owned or leased by the company that will be used in the execution of the works; (Key equipment required: Pick-up truck, Hoisting equipment, Generator, Scaffolding, Earth Test Meters, Power Analyzer, Insulation Tester, Clamp Meter, Multi-Meter, Spring bending, aluminum safety ladders, etc.). Provide proof of ownership e.g. log book or lease agreement where applicable not older than Yr 2023 (1mark each)	5 Marks
5	Warranty	Provide a warranty for at least 2 years from date of commissioning for the Automatic Voltage Regulator	4 marks
6	Delivery Schedule	<p>Attach a work program/delivery schedule in the form of a Gantt chart specifying the lead time for the electrical works for all facilities in this Lot.</p> <p>i. 12 weeks or less (5 marks)</p> <p>ii. More than 12 weeks (2marks)</p> <p>iii. Not specified (0 mark)</p>	5 Marks
7	Proof of Electrical Works	<p>Provide proof of construction works within the last 5 years – 2019 to date specifying the value <i>(do attach invoices/contracts /completion certificates)</i></p> <p>i. More than 2 proofs of work - (10marks)</p> <p>ii. Provided up to 2 proofs of work – (5 marks)</p> <p>iii. Not provided/Irrelevant – (0 mark)</p> <p><i>(The experience of all partners in a joint venture and sub-contractors will also be considered)</i></p>	10 Marks

14	Provide applicants litigation History- if any (attach Sworn affidavit by a lawyer) i. Provided/Declared (2 marks) ii. Not provided (0 marks)	2 Marks
TOTAL		60 MARKS

Any bidder who scores at least **40 Marks out of 60 Marks** shall qualify for the next stage of financial evaluation.

STAGE 3: Financial Evaluation

Upon completion of the technical evaluation a detailed financial evaluation shall follow.

The evaluation shall be in three stages;

- a) Determination of Arithmetic errors
- b) Comparison of Rates; and
- c) Consistency of the Rates.

(a) Determination of Arithmetic Errors

Arithmetic Errors will be corrected by the Procuring Entity as follows:

- i. In the event of a discrepancy between the tender amount as stated in the form of Tender and the corrected tender figure in the Main summary of the Bills of Quantities, the amount as stated in the Form of Tender shall prevail. Pursuant to Section 82 of the Public Procurement and Asset Disposal Act 2015, the tender sum as submitted and read out during the tender opening shall be absolute and final and shall not be the subject of correction, adjustment or amendment in any way by any person or entity;
- ii. Error correction factor shall be computed by expressing the difference between the amount and the corrected tender sum as a percentage of the corrected contract works (i.e. corrected tender sum less P.C; and Provisional Sums);
- iii. The Error correction factor shall be applied to all contract works (as a rebate or addition as the case may be) for the purposes of valuations for Interim Certificates and valuation of variations.

(b) Comparison of rates

Items that are under-priced or overpriced may indicate potential for non-delivery and front loading respectively. The committee shall promptly write to the tenderer asking for detailed breakdown of costs for any of the quoted items, relationship between those prices, proposed construction/installation methods and schedules.

The evaluation committee shall evaluate the responses and make an appropriate recommendation to the procuring entity giving necessary evidence. Such recommendations may include but not limited to:

- i. Recommend no adverse action to the tenderer after a convincing response;
- ii. Employer requiring that the amount of the performance bond be raised at the expense of the successful tenderer to a level sufficient to protect the employer against potential financial losses;
- iii. Recommend non-award based on the response provided and the available demonstrable evidence that the scope, quality, completion timing, administration of works to be undertaken by the tenderer, would adversely be affected or the rights of the employer or the tenderers obligations would be limited in a substantial way.

(c) Consistency of the Rates

The evaluation committee will compare the consistency of rates for similar items and note all inconsistencies of the rates for similar items.

STAGE 4: Due Diligence

The Evaluation Committee shall subject shortlisted bidder(s) considered for award for due diligence check prior to award.

SECTION IV: Conditions of Contract

1 Definitions

1.1 In this Contract, except where context otherwise requires, the following terms shall be interpreted as indicated;

“Bill of Quantities” means the priced and completed Bill of Quantities forming part of the tender.

“Compensation Events” are those defined in Clause 24 hereunder.

“The Completion Date” means the date of completion of the Works as certified by the Project Manager, in accordance with Clause 31.

“The Contract” means the agreement entered into between the Employer and the Contractor as recorded in the Agreement Form and signed by the parties including all attachments and appendices thereto and all documents incorporated by reference therein to execute, complete, and maintain the Works,

“The Contractor” refers to the person or corporate body whose tender to carry out the Works has been accepted by the Employer.

“The Contractor’s Tender” is the completed tendering document submitted by the Contractor to the Employer.

“The Contract Price” is the price stated in the Letter of Acceptance and thereafter as adjusted in accordance with the provisions of the Contract.

“Days” are calendar days; “Months” are calendar months.

“A Defect” is any part of the Works not completed in accordance with the Contract.

“The Defects Liability Certificate” is the certificate issued by Project Manager upon correction of defects by the Contractor.

“The Defects Liability Period” is the period named in the Contract Data and calculated from the Completion Date.

“Drawings” include calculations and other information provided or approved by the Project Manager for the execution of the Contract.

“Dayworks” are Work inputs subject to payment on a time basis for labour and the associated materials and plant.

“Client”, or the “Procuring entity” as defined in the Public Procurement Regulations (i.e. National or County Government administration, Universities, Public Institutions and Corporations, etc) is the party who employs the Contractor to carry out the Works.

“Equipment” is the Contractor’s machinery and vehicles brought temporarily to the Site for the execution of the Work.

“The Intended Completion Date” is the date on which it is intended that the Contractor shall complete the Works. The Intended Completion Date may be revised only by the Project Manager by issuing an extension of time or an acceleration order.

“Materials” are all supplies, including consumables, used by the Contractor for incorporation in the Works.

“Plant” is any integral part of the Works that shall have a mechanical, electrical, chemical, or biological function.

“Project Manager” is the person named in the Appendix to Conditions of Contract (or any other competent person appointed by the Employer and notified to the Contractor, to act in replacement of the Project Manager) who is responsible for supervising the execution of the Works and administering the Contract.

“Site” is the area defined as such in the Appendix to Condition of Contract.

“Site Investigation Reports” are those reports that may be included in the tendering documents which are factual and interpretative about the surface and subsurface conditions at the Site.

“Specifications” means the Specifications of the Works included in the Contract and any modification or addition made or approved by the Project Manager.

“Start Date” is the latest date when the Contractor shall commence execution of the Works. It does not necessarily coincide with the Site possession date(s).

“A Subcontractor” is a person or corporate body who has a Contract with the Contractor to carry out a part of the Work in the Contract, which includes Work on the Site.

“Temporary works” are works designed, constructed, installed, and removed by the Contractor which are needed for construction or installation of the Works.

“A Variation” is an instruction given by the Project Manager which varies the Works.

“The Works” are what the Contract requires the Contractor to construct, install, and turnover to the Employer, as defined in the Appendix to Conditions of Contract.

2 Interpretation

2.1 In interpreting these Conditions of Contract, singular also means plural, male also means female or neuter, and the other way around. Headings have no significance. Words have their normal meaning in English Language unless specifically defined. The Project Manager will provide instructions clarifying queries about these Conditions of Contract.

2.2 If sectional completion is specified in the Appendix to Conditions of Contract, reference in the Conditions of Contract to the Works, the Completion Date and the Intended Completion Date apply to any section of the Works (other than references to the Intended Completion Date for the whole of the Works).

2.3 The following documents shall constitute the Contract documents and shall be interpreted in the

following order of priority;

- i. Agreement,
- ii. Letter of Acceptance,
- iii. Contractor's Tender,
- iv. Appendix to Conditions of Contract,
- v. Conditions of Contract,
- vi. Specifications,
- vii. Bill of Quantities,
- viii. Any other documents listed in the Appendix to Conditions of Contract as forming part of the Contract.

2.4 Immediately after the execution of the Contract, the Project Manager shall furnish both the Client and the Contractor with two copies each of all the Contract documents. Further, as and when necessary the Project Manager shall furnish the Contractor [always with a copy to the Client] with three [3] copies of such further details or descriptive schedules as are reasonably necessary either to enable the Contractor to carry out and complete the Works in accordance with these Conditions.

3 Language and Law

3.1 Language of the Contract and the law governing the Contract shall be English language and the Laws of Kenya respectively unless otherwise stated.

4 Project Manager's Decisions

4.1 Except where otherwise specifically stated, the Project Manager will decide contractual matters between the Employer and the Contractor in the role representing the Employer.

5 Delegation

5.1 The Project Manager may delegate any of his duties and responsibilities to others after notifying the Contractor.

6 Communications

6.1 Communication between parties shall be effective only when in writing. A notice shall be effective only when it is delivered.

7 Subcontracting

7.1 The Contractor may subcontract with the approval of the Project Manager, but may not assign the Contract without the approval of the Employer in writing. Subcontracting shall not alter the Contractor's obligations.

8 Other Contractors

8.1 The Contractor shall cooperate and share the Site with other contractors, public authorities, utilities etc. as listed in the Appendix to Conditions of Contract and also with the Employer, as per the directions of the Project Manager. The Contractor shall also provide facilities and services for them. The Employer may modify the said List of Other Contractors etc., and shall notify the Contractor of any such modification.

9 Personnel

- 9.1 The Contractor shall employ the key personnel named in the Qualification Information, to carry out the functions stated in the said Information or other personnel approved by the Project Manager. The Project Manager will approve any proposed replacement of key personnel only if their relevant qualifications and abilities are substantially equal to or better than those of the personnel listed in the Qualification Information. If the Project Manager asks the Contractor to remove a person who is a member of the Contractor's staff or work force, stating the reasons, the Contractor shall ensure that the person leaves the Site immediately days and has no further connection with the Work in the Contract.

10 Works

- 10.1 The Contractor shall construct and install the Works in accordance with the Specifications and Drawings. The Works may commence on the Start Date and shall be carried out in accordance with the Program submitted by the Contractor, as updated with the approval of the Project Manager, and complete them by the Intended Completion Date.

11 Safety and Temporary Works

- 11.1 The Contractor shall be responsible for the design of temporary works. However before erecting the same, he shall submit his designs including specifications to the Project Manager and to any other relevant third parties for their approval. No erection of temporary works shall be done until such approvals are obtained.
- 11.2 The Project Manager's approval shall not alter the Contractor's responsibility for design of the Temporary works prepared by the Contractor for the execution of the temporary or permanent Works, shall be subject to prior approval by the Project Manager before they can be used.
- 11.3 The Contractor shall be responsible for the safety of all activities on the Site.
- 11.4 Occupational Safety and Health Administration (OSHA). The Contractor will be required to comply with OSHA requirements during installation works. The Contractor will be required to provide risk assessment and safety methods statements prior to work commencement.

12 Discoveries

- 12.1 Anything of historical or other interest or of significant value unexpectedly discovered on Site shall be the property of the Employer. The Contractor shall notify the Project Manager of such discoveries and carry out the Project Manager's instructions for dealing with them.

13 Work Program

- 13.1 Within the time stated in the Appendix to Conditions of Contract, the Contractor shall submit to the Project Manager for approval a program showing the general methods, arrangements, order, and timing for all the activities in the Works. An update of the program shall be a program showing the actual progress achieved on each activity and the effect of the progress achieved on the timing of the remaining Work, including any changes to the sequence of the activities.
- 13.2 The Contractor shall submit to the Project Manager for approval an updated program at intervals no longer than the period stated in the Appendix to Conditions of Contract. If the Contractor

does not submit an updated program within this period, the Project Manager may withhold the amount stated in the said Appendix from the next payment certificate and continue to withhold this amount until the next payment after the date on which the overdue program has been submitted. The Project Manager's approval of the program shall not alter the Contractor's obligations. The Contractor may revise the program and submit it to the Project Manager again at any time. A revised program shall show the effect of Variations and Compensation Events.

14 Possession of Site

14.1 The Employer shall give possession of all parts of the Site to the Contractor. If possession of a part is not given by the date stated in the Appendix to Conditions of Contract, the Employer will be deemed to have delayed the start of the relevant activities, and this will be a Compensation Event.

15 Access to Site

15.1 The Contractor shall allow the Project Manager and any other person authorized by the Project Manager, access to the Site and to any place where work in connection with the Contract is being carried out or is intended to be carried out.

16 Instructions

16.1 The Contractor shall carry out all instructions of the Project Manager which are in accordance with the Contract.

17 Extension or Acceleration of Completion Date

17.1 The Project Manager shall extend the Intended Completion Date if a Compensation Event occurs or a variation is issued which makes it impossible for completion to be achieved by the Intended Completion Date without the Contractor taking steps to accelerate the remaining Work, which would cause the Contractor to incur additional cost. The Project Manager shall decide whether and by how much to extend the Intended Completion Date within 21 days of the Contractor asking the Project Manager in writing for a decision upon the effect of a Compensation Event or variation and submitting full supporting information. If the Contractor has failed to give early warning of a delay or has failed to cooperate in dealing with a delay, the delay caused by such failure shall not be considered in assessing the new (extended) Completion Date.

17.2 No bonus for early completion of the Works shall be paid to the Contractor by the Employer.

18 Management Meetings

18.1 A Contract management meeting shall be held monthly and attended by the Project Manager and the Contractor. Its business shall be to review the plans for the remaining Work and to deal with matters raised in accordance with the early warning procedure. The Project Manager shall record the minutes of management meetings and provide copies of the same to those attending the meeting and the Employer. The responsibility of the parties for actions to be taken shall be decided by the Project Manager either at the management meeting or after the management meeting and stated in writing to all who attended the meeting.

19 Early Warning

19.1 The Contractor shall warn the Project Manager at the earliest opportunity of specific likely future

events or circumstances that may adversely affect the quality of the Work, increase the Contract Price or delay the execution of the Works. The Project Manager may require the Contractor to provide an estimate of the expected effect of the future event or circumstance on the Contract Price and Completion Date. The estimate shall be provided by the Contractor as soon as reasonably possible.

- 19.2 The Contractor shall cooperate with the Project Manager in making and considering proposals on how the effect of such an event or circumstance can be avoided or reduced by anyone involved in the Work and in carrying out any resulting instructions of the Project Manager.

20 Defects

- 20.1 The Project Manager shall inspect the Contractor's work and notify the Contractor of any defects that are found. Such inspection shall not affect the Contractor's responsibilities. The Project Manager may instruct the Contractor to search for a defect and to uncover and test any Work that the Project Manager considers may have a defect. Should the defect be found, the cost of uncovering and making good shall be borne by the Contractor, However, if there is no defect found, the cost of uncovering and making good shall be treated as a variation and added to the Contract Price.
- 20.2 The Project Manager shall give notice to the Contractor of any defects before the end of the Defects Liability Period, which begins at Completion, and is defined in the Appendix to Conditions of Contract. The Defects Liability Period shall be extended for as long as defects remain to be corrected.
- 20.3 Every time notice of a defect is given, the Contractor shall correct the notified defect within the length of time specified by the Project Manager's notice. If the Contractor has not corrected a defect within the time specified in the Project Manager's notice, the Project Manager will assess the cost of having the defect corrected by other parties and such cost shall be treated as a variation and be deducted from the Contract Price.

21 Bills of Quantities

- 21.1 The Bills of Quantities shall contain items for the construction, installation, testing and commissioning of the Work to be done by the Contractor. The Contractor will be paid for the quantity of the Work done at the rate in the Bills of Quantities for each item.
- 21.2 If the final quantity of the Work done differs from the quantity in the Bills of Quantities for the particular item by more than 25 percent and provided the change exceeds 1 percent of the Initial Contract price, the Project Manager shall adjust the rate to allow for the change.
- 21.3 If requested by the Project Manager, the Contractor shall provide the Project Manager with a detailed cost breakdown of any rate in the Bills of Quantities.

22 Variations

- 22.1 All variations shall be included in updated programs produced by the Contractor.
- 22.2 The Contractor shall provide the Project Manager with a quotation for carrying out the variations when requested to do so. The Project Manager shall assess the quotation, which shall be given

within seven days of the request or within any longer period as may be stated by the Project Manager and before the Variation is ordered.

- 22.3 If the work in the variation corresponds with an item description in the Bills of Quantities and if in the opinion of the Project Manager, the quantity of work is not above the limit stated in Clause 21.2 or the timing of its execution does not cause the cost per unit of quantity to change, the rate in the Bills of Quantities shall be used to calculate the value of the variation. If the cost per unit of quantity changes, or if the nature or timing of the work in the variation does not correspond with items in
- 22.4 The Bills of Quantities, the quotation by the Contractor shall be in the form of new rates for the relevant items of Work.
- 22.5 If the Contractor's quotation is unreasonable, the Project Manager may order the variation and make a change to the Contract price, which shall be based on the Project Manager's own forecast of the effects of the variation on the Contractor's costs.
- 22.6 If the Project Manager decides that the urgency of varying the Work would prevent a quotation being given and considered without delaying the Work, no quotation shall be given and the variation shall be treated as a Compensation Event.
- 22.7 The Contractor shall not be entitled to additional payment for costs that could have been avoided by giving early warning.
- 22.8 When the Program is updated, the Contractor shall provide the Project Manager with an updated cash flow forecast.

23 Payment Certificates, Currency of Payments and Advance Payments

- 23.1 The Contractor shall submit to the Project Manager monthly applications for payment giving sufficient details of the Work done and materials on Site and the amounts which the Contractor considers himself to be entitled to. The Project Manager shall check the monthly application and certify the amount to be paid to the Contractor within 14 days. The value of Work executed and payable shall be determined by the Project Manager.
- 23.2 The value of Work executed shall comprise the value of the quantities of the items in the Bills of Quantities completed, materials delivered on Site, variations and compensation events. Such materials shall become the property of the Employer once the Employer has paid the Contractor for their value. Thereafter, they shall not be removed from Site without the Project Manager's instructions except for use upon the Works.
- 23.3 Payments shall be adjusted for deductions for retention. The Employer shall pay the Contractor the amounts certified by the Project Manager within 30 days of the date of issue of each certificate. If the Employer makes a late payment, the Contractor shall be paid simple interest on the late payment in the next payment. Interest shall be calculated on the basis of number of days delayed at a rate three percentage points above the Central Bank of Kenya's average rate for base lending prevailing as of the first day the payment becomes overdue.
- 23.4 If an amount certified is increased in a later certificate or as a result of an award by an Arbitrator,

the Contractor shall be paid interest upon the delayed payment as set out in this clause. Interest shall be calculated from the date upon which the increased amount would have been certified in the absence of dispute.

23.5 Items of the Works for which no rate or price has been entered in will not be paid for by the Employer and shall be deemed covered by other rates and prices in the Contract.

23.6 The Contract Price shall be stated in Kenya Shillings. All payments to the Contractor shall be made in Kenya Shillings and foreign currency in the proportion indicated in the tender, or agreed prior to the execution of the Contract Agreement and indicated therein. The rate of exchange for the calculation of the amount of foreign currency payment shall be the rate of exchange indicated in the Appendix to Conditions of Contract. If the Contractor indicated foreign currencies for payment other than the currencies of the countries of origin of related goods and services, the Employer reserves the right to pay the equivalent at the time of payment in the currencies of the countries of such goods and services. The Employer and the Project Manager shall be notified promptly by the Contractor of any changes in the expected foreign currency requirements of the Contractor during the execution of the Works as indicated in the Schedule of Foreign Currency Requirements and the foreign and local currency portions of the balance of the Contract Price shall then be amended by agreement between Employer and the Contractor in order to reflect appropriately such changes.

23.7 In the event that an advance payment is granted, the following shall apply: -

- a) On signature of the Contract, the Contractor shall at his request, and without furnishing proof of expenditure, be entitled to an advance of 10% (ten percent) of the original amount of the Contract. The advance shall not be subject to retention money.
- b) No advance payment may be made before the Contractor has submitted proof of the establishment of deposit or a directly liable guarantee satisfactory to the Employer in the amount of the advance payment. The guarantee shall be in the same currency as the advance.
- c) Reimbursement of the lump sum advance shall be made by deductions from the Interim payments and where applicable from the balance owing to the Contractor. Reimbursement shall begin when the amount of the sums due under the Contract reaches 20% of the original amount of the Contract. It shall have been completed by the time 80% of this amount is reached.

The amount to be repaid by way of successive deductions shall be calculated by means of the formula:

$$R = \frac{A(x^1 - x^{11})}{80-20}$$

Where:

R = the amount to be reimbursed

- A = the amount of the advance which has been granted
- X^1 = the amount of proposed cumulative payments as a percentage of the original amount of the Contract. This figure will exceed 20% but not exceed 80%.
- X^{11} = the amount of the previous cumulative payments as a percentage of the original amount of the Contract. This figure will be below 80% but not less than 20%.
- a) with each reimbursement the counterpart of the directly liable guarantee may be reduced accordingly.

24 Compensation Events

24.1 The following issues shall constitute Compensation Events:

- a) The Employer does not give access to a part of the Site by the Site Possession Date stated in the Appendix to Conditions of Contract.
- b) The Employer modifies the List of Other Contractors, etc., in a way that affects the Work of the Contractor under the Contract.
- c) The Project Manager orders a delay or does not issue drawings, specifications or instructions required for execution of the Works on time.
- d) The Project Manager instructs the Contractor to uncover or to carry out additional tests upon the Work, which is then found to have no defects.
- e) The Project Manager unreasonably does not approve a subcontract to be let.
- f) Ground conditions are substantially more adverse than could reasonably have been assumed before issuance of the Letter of Acceptance from the information issued to tenderers (including the Site investigation reports), from information available publicly and from a visual inspection of the Site.
- g) The Project Manager gives an instruction for dealing with an unforeseen condition, caused by the Employer or additional work required for safety or other reasons.
- h) Other contractors, public authorities, utilities, or the Employer does not work within the dates and other constraints stated in the Contract, and they cause delay or extra cost to the Contractor.
- i) The effects on the Contractor of any of the Employer's risks.
- j) The Project Manager unreasonably delays issuing a Certificate of Completion.
- k) Other compensation events described in the Contract or determined by the Project Manager shall apply.

24.2 If a compensation event would cause additional cost or would prevent the Work being completed before the Intended Completion Date, the Contract Price shall be increased and/or the Intended

Completion Date shall be extended. The Project Manager shall decide whether and by how much the Contract Price shall be increased and whether and by how much the Intended Completion Date shall be extended.

- 24.3 As soon as information demonstrating the effect of each compensation event upon the Contractor's forecast cost has been provided by the Contractor, it shall be assessed by the Project Manager, and the Contract Price shall be adjusted accordingly. If the Contractor's forecast is deemed unreasonable, the Project Manager shall adjust the Contract Price based on the Project Manager's own forecast. The Project Manager will assume that the Contractor will react competently and promptly to the event.
- 24.4 The Contractor shall not be entitled to compensation to the extent that the Employer's interests are adversely affected by the Contractor not having given early warning or not having co-operated with the Project Manager.
- 24.5 Prices shall be adjusted for fluctuations in the cost of inputs only if provided for in the Appendix to Conditions of Contract.
- 24.6 The Contractor shall give written notice to the Project Manager of his intention to make a claim within thirty days after the event giving rise to the claim has first arisen. The claim shall be submitted within thirty days thereafter provided always that should the event giving rise to the claim of continuing effect, the Contractor shall submit an interim claim within the said thirty days and a final claim within thirty days of the end of the event giving rise to the claim.

25 Price Adjustment

- 25.1 The Project Manager shall adjust the Contract Price if taxes, duties and other levies are changed between the date 30 days before the submission of tenders for the Contract and the date of Completion. The adjustment shall be the change in the amount of tax payable by the Contractor.
- 25.2 The Contract Price shall be deemed to be based on exchange rates current at the date of tender submission in calculating the cost to the Contractor of materials to be specifically imported (by express provisions in the Contract Bills of Quantities or Specifications) for permanent incorporation in the Works. Unless otherwise stated in the Contract, if at any time during the period of the Contract exchange rates shall be varied and this shall affect the cost to the Contractor of such materials, then the Project Manager shall assess the net difference in the cost of such materials. Any amount from time to time so assessed shall be added to or deducted from the Contract Price, as the case may be.
- 25.3 Unless otherwise stated in the Contract, the Contract Price shall be deemed to have been calculated in the manner set out below and in sub-clauses 25.4 and 25.5 and shall be subject to adjustment in the events specified thereunder;
- i. The prices contained in the Contract Bills of Quantities shall be deemed to be based upon the rates of wages and other emoluments and expenses as determined by the Joint Building Council of Kenya (J.B.C.) and set out in the schedule of basic rates issued 30 days before the date for submission of tenders. A copy of the schedule used by the Contractor in his pricing shall be attached in the Appendix to Conditions of Contract.

- ii. Upon J.B.C. determining that any of the said rates of wages or other emoluments and expenses are increased or decreased, then the Contract Price shall be increased or decreased by the amount assessed by the Project Manager based upon the difference, expressed as a percentage, between the rate set out in the schedule of basic rates issued 30 days before the date for submission of tenders and the rate published by the J.B.C. and applied to the quantum of labour incorporated within the amount of Work remaining to be executed at the date of publication of such increase or decrease.
- iii. No adjustment shall be made in respect of changes in the rates of wages and other emoluments and expenses which occur after the date of Completion except during such other period as may be granted as an extension of time under clause 17.0 of these Conditions.

25.4 The prices contained in the Contract Bills of Quantities shall be deemed to be based upon the basic prices of materials to be permanently incorporated in the Works as determined by the J.B.C. and set out in the schedule of basic rates issued 30 days before the date for submission of tenders. A copy of the schedule used by the Contractor in his pricing shall be attached in the Appendix to Conditions of Contract.

25.5 Upon the J.B.C. determining that any of the said basic prices are increased or decreased then the Contract Price shall be increased or decreased by the amount to be assessed by the Project Manager based upon the difference between the price set out in the schedule of basic rates issued 30 days before the date for submission of tenders and the rate published by the J.B.C. and applied to the quantum of the relevant materials which have not been taken into account in arriving at the amount of any interim certificate under clause 23 of these Conditions issued before the date of publication of such increase or decrease.

25.6 No adjustment shall be made in respect of changes in basic prices of materials which occur after the date for Completion except during such other period as may be granted as an extension of time under clause 17.0 of these Conditions. The provisions of sub-clause 25.1 to 25.2 herein shall not apply in respect of any materials included in the schedule of basic rates.

26 Retention

26.1 The Employer shall retain from each payment due to the Contractor the proportion stated in the Appendix to Conditions of Contract until Completion of the whole of the Works. On Completion of the whole of the Works, half the total amount retained shall be repaid to the Contractor and the remaining half when the Defects Liability Period has passed and the Project Manager has certified that all defects notified to the Contractor before the end of this period have been corrected.

27 Liquidated Damages

27.1 The Contractor shall pay liquidated damages to the Employer at the rate stated in the Appendix to Conditions of Contract for each day that the actual Completion Date is later than the Intended Completion Date. The Employer may deduct liquidated damages from payments due to the Contractor. Payment of liquidated damages shall not alter the Contractor's liabilities.

27.2 If the Intended Completion Date is extended after liquidated damages have been paid, the Project Manager shall correct any overpayment of liquidated damages by the Contractor by adjusting the

next payment certificate. The Contractor shall be paid interest on the overpayment, calculated from the date of payment to the date of repayment, at the rate specified in Clause 23.3.

28 Securities

28.1 The Performance Security shall be provided to the Employer no later than the date specified in the Letter of Acceptance and shall be issued in an amount and form and by a reputable bank acceptable to the Employer, and denominated in Kenya Shillings. The Performance Security shall be valid until a date 30 days beyond the date of issue of the Certificate of Completion.

29 Dayworks

29.1 If applicable, the Dayworks rates in the Contractor's tender shall be used for small additional amounts of Work only when the Project Manager has given written instructions in advance for additional work to be paid for in that way.

29.2 All work to be paid for as Dayworks shall be recorded by the Contractor on Forms approved by the Project Manager. Each completed form shall be verified and signed by the Project Manager within two days of the Work being done.

29.3 The Contractor shall be paid for Dayworks subject to obtaining signed Dayworks forms.

30 Liability and Insurance

30.1 From the Start Date until the Defects Correction Certificate has been issued, the following are the Employer's risks: The risk of personal injury, death or loss of or damage to property (excluding the Works, Materials and Equipment), which are due to;

- i. use or occupation of the Site by the Works or for the purpose of the Works, which is the unavoidable result of the Works, or
- ii. negligence, breach of statutory duty or interference with any legal right by the Employer or by any person employed by or contracted to him except the Contractor.
- iii. the risk of damage to the Works, Plant, Materials, and Equipment to the extent that it is due to a fault of the Employer or in Employer's design, or due to war or radioactive contamination directly affecting the place where the Works are being executed.

30.2 From the Completion Date until the Defects Correction Certificate has been issued, the risk of loss of or damage to the Works, Equipment, and Materials is the Employer's risk except loss or damage due to;

- (a) a defect which existed on or before the Completion Date.
- (b) an event occurring before the Completion Date, which was not itself the Employer's risk
- (c) the activities of the Contractor on the Site after the Completion Date.

30.3 From the Start Date until the Defects Correction Certificate has been issued, the risks of personal injury, death and loss of or damage to property (including, without limitation, the Works, Plant, Materials, and Equipment) which are not Employer's risk are Contractor's risks.

The Contractor shall provide, in the joint names of the Employer and the Contractor, insurance cover from the Start Date to the end of the Defects Liability Period, in the amounts stated in the Appendix to Conditions of Contract for the following events;

- (a) loss of or damage to the Works, Plant, and Materials;
 - (b) loss of or damage to Equipment;
 - (c) loss of or damage to property (except the Works, Plant, Materials, and Equipment) in connection with the Contract, and
 - (d) personal injury or death.
- 30.4 Policies and certificates for insurance shall be delivered by the Contractor to the Project Manager for the Project Manager's approval before the Start Date. All such insurance shall provide for compensation required to rectify the loss or damage incurred.
- 30.5 If the Contractor does not provide any of the policies and certificates required, the Employer may effect the insurance which the Contractor should have provided and recover the premiums from payments otherwise due to the Contractor or, if no payment is due, the payment of the premiums shall be a debt due.
- 30.6 Alterations to the terms of an insurance shall not be made without the approval of the Project Manager. Both parties shall comply with any conditions of insurance policies. Completion and taking over upon deciding that the Works are complete, the Contractor shall issue a written request to the Project Manager to issue a Certificate of Completion of the Works. The Employer shall take over the Site and the Works within seven [7] days of the Project Manager's issuing a Certificate of Completion.

31 Final Account

- 31.1 The Contractor shall issue the Project Manager with a detailed account of the total amount that the Contractor considers payable to him by the Employer under the Contract before the end of the Defects Liability Period. The Project Manager shall issue a Defects Liability Certificate and certify any final payment that is due to the Contractor within 30 days of receiving the Contractor's account if it is correct and complete. If it is not, the Project Manager shall issue within 30 days a schedule that states the scope of the corrections or additions that are necessary. If the final account is still unsatisfactory after it has been resubmitted, the Project Manager shall decide on the amount payable to the Contractor and issue a Payment Certificate. The Employer shall pay the Contractor the amount due in the Final Certificate within 60 days.

32 Termination

- 32.1 The Employer or the Contractor may terminate the Contract if the other party causes a fundamental breach of the Contract. These fundamental breaches of Contract shall include, but shall not be limited to, the following;
- (a) the Contractor stops work for 30 days when no stoppage of work is shown on the current program and the stoppage has not been authorized by the Project Manager;
 - (b) the Project Manager instructs the Contractor to delay the progress of the Works, and the instruction is not withdrawn within 30 days;
 - (c) the Contractor is declared bankrupt or goes into liquidation other than for a reconstruction or amalgamation;
 - (d) a payment certified by the Project Manager is not paid by the Employer to the Contractor within 30 days (for Interim Certificate) or 60 days (for Final Certificate) of issue.
 - (e) the Project Manager gives notice that failure to correct a particular defect is a fundamental breach of Contract and the Contractor fails to correct it within a reasonable

- period of time determined by the Project Manager;
- (f) the Contractor does not maintain a security, which is required.

32.2 When either party to the Contract gives notice of a breach of Contract to the Project Manager for a cause other than those listed under Clause 33.1 above, the Project Manager shall decide whether the breach is fundamental or not.

32.3 Notwithstanding the above, the Employer may terminate the Contract for convenience.

32.4 If the Contract is terminated, the Contractor shall stop work immediately, make the Site safe and secure, and leave the Site as soon as reasonably possible. The Project Manager shall immediately thereafter arrange for a meeting for the purpose of taking record of the Works executed and materials, goods, equipment and temporary buildings on Site.

33 Payment Upon Termination

33.1 If the Contract is terminated because of a fundamental breach of Contract by the Contractor, the Project Manager shall issue a certificate for the value of the Work done and materials ordered and delivered to Site up to the date of the issue of the certificate. Additional liquidated damages shall not apply. If the total amount due to the Employer exceeds any payment due to the Contractor, the difference shall be a debt payable by the Contractor.

33.2 If the Contract is terminated for the Employer's convenience or because of a fundamental breach of Contract by the Employer, the Project Manager shall issue a certificate for the value of the Work done, materials ordered, the reasonable cost of removal of equipment, repatriation of the Contractor's personnel employed solely on the Works, and the Contractor's costs of protecting and securing the Works.

33.3 The Employer may employ and pay other persons to carry out and complete the Works and to rectify any defects and may enter upon the Works and use all materials on the Site, plant, equipment and temporary works.

33.4 The Contractor shall, during the execution or after the completion of the Works under this clause remove from the Site as and when required, within such reasonable time as the Project Manager may in writing specify, any temporary buildings, plant, machinery, appliances, goods or materials belonging to or hired by him, and in default the Employer may (without being responsible for any loss or damage) remove and sell any such property of the Contractor, holding the proceeds less all costs incurred to the credit of the Contractor.

33.5 Until after completion of the Works under this clause the Employer shall not be bound by any other provision of this Contract to make any payment to the Contractor, but upon such completion as aforesaid and the verification within a reasonable time of the accounts therefore the Project Manager shall certify the amount of expenses properly incurred by the Employer and, if such amount added to the money paid to the Contractor before such determination exceeds the total amount which would have been payable on due completion in accordance with this Contract the difference shall be a debt payable to the Employer by the Contractor; and if the said amount added to the said money be less than the said total amount, the difference shall be a debt payable by the Employer to the Contractor.

34 Release from Performance

34.1 If the Contract is frustrated by the outbreak of war or by any other event entirely outside the control of either the Employer or the Contractor, the Project Manager shall certify that the Contract has been frustrated. The Contractor shall make the Site safe and stop Work as quickly as possible after receiving this certificate and shall be paid for all Work carried out before receiving it.

35 Corrupt gifts and payments of commission

35.1 The Contractor shall not;

- (a) Offer or give or agree to give to any person in the service of the Employer any gift or consideration of any kind as an inducement or reward for doing or forbearing to do or for having done or forborne to do any act in relation to the obtaining or execution of this or any other Contract for the Employer or for showing or forbearing to show favour or disfavour to any person in relation to this or any other contract for the Employer.
- (b) Enter into this or any other contract with the Employer in connection with which commission has been paid or agreed to be paid by him or on his behalf or to his knowledge, unless before the Contract is made particulars of any such commission and of the terms and conditions of any agreement for the payment thereof have been disclosed in writing to the Employer.

Any breach of this Condition by the Contractor or by anyone employed by him or acting on his behalf (whether with or without the knowledge of the Contractor) shall be an offence under the provisions of the Public Procurement Regulations issued under The Exchequer and Audit Act Cap 412 of the Laws of Kenya.

36 Settlement of Disputes

36.1 In case any dispute or difference shall arise between the Employer or the Project Manager on his behalf and the Contractor, either during the progress or after the completion or termination of the Works, such dispute shall be notified in writing by either party to the other with a request to submit it to arbitration and to concur in the appointment of an Arbitrator within thirty days of the notice. The dispute shall be referred to the arbitration and final decision of a person to be agreed between the parties. Failing agreement to concur in the appointment of an Arbitrator, the Arbitrator shall be appointed by the Chairman or Vice Chairman of any of the following professional institutions;

- (i) Architectural Association of Kenya
- (ii) Institute of Quantity Surveyors of Kenya
- (iii) Association of Consulting Engineers of Kenya
- (iv) Chartered Institute of Arbitrators (Kenya Branch)
- (v) Institution of Engineers of Kenya

On the request of the applying party. The institution written to first by the aggrieved party shall take precedence over all other institutions.

36.2 The arbitration may be on the construction of this Contract or on any matter or thing of whatsoever nature arising thereunder or in connection therewith, including any matter or thing left by this Contract to the discretion of the Project Manager, or the withholding by the Project Manager of any certificate to which the Contractor may claim to be entitled to or the measurement and valuation referred to in clause 23.0 of these conditions, or the rights and

liabilities of the parties subsequent to the termination of Contract.

- 36.3 Provided that no arbitration proceedings shall be commenced on any dispute or difference where notice of a dispute or difference has not been given by the applying party within ninety days of the occurrence or discovery of the matter or issue giving rise to the dispute.
- 36.4 Notwithstanding the issue of a notice as stated above, the arbitration of such a dispute or difference shall not commence unless an attempt has in the first instance been made by the parties to settle such dispute or difference amicably with or without the assistance of third parties. Proof of such attempt shall be required.
- 36.5 Notwithstanding anything stated herein the following matters may be referred to arbitration before the practical completion of the Works or abandonment of the Works or termination of the Contract by either party:
- 36.6 The appointment of a replacement Project Manager upon the said person ceasing to act.
- 36.7 Whether or not the issue of an instruction by the Project Manager is empowered by these Conditions.
- 36.8 Whether or not a certificate has been improperly withheld or is not in accordance with these Conditions.
- 36.9 Any dispute or difference arising in respect of war risks or war damage.
- 36.10 All other matters shall only be referred to arbitration after the completion or alleged completion of the Works or termination or alleged termination of the Contract, unless the Employer and the Contractor agree otherwise in writing.
- 36.11 The Arbitrator shall, without prejudice to the generality of his powers, have powers to direct such measurements, computations, tests or valuations as may in his opinion be desirable in order to determine the rights of the parties and assess and award any sums which ought to have been the subject of or included in any certificate.
- 36.12 The Arbitrator shall, without prejudice to the generality of his powers, have powers to open up, review and revise any certificate, opinion, decision, requirement or notice and to determine all matters in dispute which shall be submitted to him in the same manner as if no such certificate, opinion, decision requirement or notice had been given.
- 36.13 The award of such Arbitrator shall be final and binding upon the parties.

SECTION V: Appendix to Conditions of Contract

The Client is:

Name: Amref Health Africa

Address: P.O. Box 30125 - 00100 Nairobi

The Project Manager is:

Name:

Address:

The name (and identification number) of the Contract is the PROPOSED CONSTRUCTION OF GENERATOR HOUSING, SUPPLY, DELIVERY, INSTALLATION, TESTING, TRAINING AND COMMISSIONING OF STANDBY GENERATOR SETS AND RELATED WORKS.

The Works consist of SUPPLY, DELIVERY, INSTALLATION, TESTING, TRAINING AND COMMISSIONING OF STANDBY GENERATOR SETS AND CONSTRUCTION OF GENERATOR HOUSES as per the specifications and Bills of Quantities.

The Start Date shall be agreed with the Project Manager.

The maximum Intended Completion Date for the whole of the Works shall be **16 Weeks** after commencement date.

The following documents also form part of the Contract as listed in clause 2.1 of the Conditions of Contract.

The Contractor shall submit a revised program for the Works within 7 days of delivery of the Letter of Acceptance.

The Site Possession Date shall be agreed with the Project Manager.

The Defects Liability period will apply.

Other Contractors, utilities etc., to be engaged by the Client on the Site include those for the execution of; (Domestic Subcontractors must be registered with NCA and evidence of the same must be attached)

1. Plumbing and Drainage Works
2. Electrical Works
3. Mechanical Works
4. Building works

The minimum insurance covers shall be;

1. The minimum cover for insurance of the Works and of Plant and Materials in respect of the Contractor's faulty design is _____ Nil _____
2. The minimum cover for loss or damage to Equipment is _____ Nil
3. The minimum for insurance of other property is Kshs. 500,000.00
4. The minimum cover for personal injury or death insurance:
For the Contractor's employees is ___Kshs. 500,000.00
And for other people is _____ Kshs. 1,000,000.00

The following events shall also be Compensation Events:

1. NONE OTHER THAN AS DEFINED IN THESE CONDITIONS OF CONTRACT
- 2.
- 3.
- 4.

The period between Program updates is 7 days.

The amount to be withheld for late submission of an updated Program is FULL CERTIFICATE

The proportion of payments retained is 10 percent (%).

The Price Adjustment Clause SHALL NOT apply.

The liquidated damages for the whole of the Works is Kshs. 10,000 [per Week].

The Performance Security shall be for the following minimum amounts equivalent as a percentage of the Contract Price 10 percent (%).

The Completion Period for the Works is 16 [Weeks].

The rate of exchange for calculation of foreign currency payments is NOT APPLICABLE

The schedule of basic rates used in pricing by the Contractor is as ISSUED BY THE JOINT BUILDING COUNCIL (JBC - KENYA) THIRTY DAYS BEFORE THE DATE OF SUBMISSION OF TENDERS

Advance Payment SHALL NOT APPLY.

The Bidder should submit only ONE (1 No.) set of the Bills of Quantities as indicated in clause 4.1 of the Instruction to Tenderers.

SECTION VI: Standard Forms

- 1) Form of Invitation for Tenders
- 2) Form of Tender
- 3) Letter of Award
- 4) Form of Agreement
- 5) Form of Tender Security
- 6) Performance Bank Guarantee
- 7) Bank Guarantee for Advance Payment
- 8) Qualification Information
- 9) Confidential Business Questionnaire
- 10) Details of Sub-Contractors

Form of Invitation for Tenders

_____ [date]

To: _____ [Name of Contractor]

_____ [Address of Contractor]

Dear Sirs:

Reference _____ [Contract Name]

You have been prequalified to tender for the above project.

We hereby invite you and other prequalified tenderers to submit a tender for the execution and completion of the above Contract.

A complete set of tender documents may be purchased by you from _____

[mailing address]

Upon payment of a non-refundable fee of Kshs _____

All tenders must be accompanied by _____ number of copies of the same and a security in the form and amount specified in the tendering documents, and must be delivered to

[address and location]

at or before _____

[time and date]

Tender will be opened immediately thereafter, in the presence of tenderer's representatives who choose to attend.

Please confirm receipt of this letter immediately in writing by email.

Yours faithfully,

_____ [Authorized Signature]

_____ [Name and Title]

Form of Tender

To: Amref Health Africa [Name of Client]

_____ [Date]

[Name of Contract]

Dear Sir,

In accordance with the Conditions of Contract, Specifications and Bills of Quantities for the execution of the above-named Works, we, the undersigned offer to construct, install and complete such Works and remedy any defects therein for the sum of Kshs

[Amount in Figures]

[Amount in Words]

We undertake, if our tender is accepted, to commence the Works as soon as is reasonably possible after the receipt of the Project Manager's notice to commence, and to complete the whole of the Works comprised in the Contract within the time stated in the Appendix to Conditions of Contract.

We agree to abide by this tender until . [Insert date], and it shall remain binding upon us and may be accepted at any time before that date.

Unless and until a formal Agreement is prepared and executed this tender together with your written acceptance thereof, shall constitute a binding Contract between us.

We understand that you are not bound to accept the lowest or any tender you may receive.

Dated this _____ day of _____ 20 _____

Signature _____ in the capacity of _____

Duly authorized to sign tenders on behalf of _____
[Name of the Contractor]

[Address of the Contractor]

Witness Name: _____

Address: _____

Signature: _____

Date: _____

Letter of Award

for the execution

[letterhead paper of the Employer]

[date]

To:

[name of the Contractor]

[address of the Contractor]

Dear Sir,

This is to notify you that your
tender dated

[name of the Contract and tender number as given in the Tender documents]

for the Contract Price of Kshs. _____ [amount in figures] [Kenya Shillings]

_ [Amount in words] in accordance with the Instructions to Tenderers is hereby accepted.

You are hereby instructed to proceed with the execution of the said Works in accordance with the Contract documents.

Authorized Signature

Name and Title of Signatory

Attachment: Agreement

Form of Agreement

THIS AGREEMENT, made on the _____ day of ____ 20 _____ between _____ of [or whose registered office is situated at] _____ (hereinafter called “the Client”) of the one part

AND

_____ of [or whose registered office is situated at] _____ (hereinafter called “the Contractor”) of the other part.

WHEREAS THE Employer is desirous that the Contractor executes _____ (name and identification number of Contract) (hereinafter called “the Works”) located at _____ [Place/location of the Works] and the Client has accepted the tender submitted by the Contractor for the execution and completion of such Works and the remedying of any defects therein for the Contract Price of Kshs _____ [Amount in figures], Kenya Shillings _____ [Amount in words].

NOW THIS AGREEMENT WITNESSETH as follows:

1. In this Agreement, words and expressions shall have the same meanings as are respectively assigned to them in the Conditions of Contract hereinafter referred to.
2. The following documents shall be deemed to form and shall be read and construed as part of this Agreement i.e.
 - a) Letter of Acceptance Form of Tender
 - b) Conditions of Contract Part I
 - c) Conditions of Contract Part II and Appendix to Conditions of Contract Specifications
 - d) Priced Bills of Quantities
3. In consideration of the payments to be made by the Client to the Contractor as hereinafter mentioned, the Contractor hereby covenants with the Employer to execute and complete the Works and remedy any defects therein in conformity in all respects with the provisions of the Contract.
4. The Employer hereby covenants to pay the Contractor in consideration of the execution and completion of the Works and the remedying of defects therein, the Contract Price or such other sum as may become payable under the provisions of the Contract at the times and in the manner prescribed by the Contract.

IN WITNESS, WHEREOF the Parties have caused this Agreement to be executed by their duly appointed representatives on the date first above-mentioned.

For and on Behalf of:

[Contractor's Name]
[Contractors Address]

Name

Position

Signature

Witness Name

Witness Signature

Witness Name

Witness Signature

Place Company Stamp Here

For and on Behalf of:

[Clients Name]
[Contractors Address]

Name

Position

Signature

Witness Name

Witness Signature

Witness Name

Witness Signature

Place Company Stamp Here

Form of Tender Security

Tender No. Amref

PROPOSED CONSTRUCTION OF GENERATOR HOUSING, SUPPLY, DELIVERY, INSTALLATION, TESTING, TRAINING AND COMMISSIONING OF STANDBY GENERATOR SETS AND RELATED WORKS – LOT NO.....

To: Amref Health Africa

WHEREAS *[insert: name of Tenderer]* (hereinafter called “the Tenderer”) has submitted its tender dated *[insert: date of tender]* for the performance of the above-named Contract (hereinafter called “the Tender”)

KNOW ALL PERSONS by these present that WE *[insert: name of bank]* of *[insert: address of bank]* (hereinafter called “the Bank”) are bound unto *[insert: name of Purchaser]* (hereinafter called “the Purchaser”) in the sum of: *[insert: amount]*, for which payment well and truly to be made to the said Purchaser, the Bank binds itself, its successors and assigns by these presents.

Sealed with the Common Seal of the said Bank this *[insert: number]* day of *[insert: month]*, *[insert: year]*.

THE CONDITIONS of this obligation are the following:

1. If, after the tender submission deadline, the Tenderer
 - (a) withdraws its tender during the period of tender validity specified by the Tenderer in the Tender Form, or
 - (b) does not accept the Purchaser’s corrections of arithmetic errors in accordance with the Instructions to Tenderers; or
 - (c) does not at all reply to the Purchaser’s requests for clarification
2. If the Tenderer, having been notified of the acceptance of its tender by the Purchaser during the period of tender validity.
 - (a) Fails or refuses to sign the Contract Agreement when required; or
 - (b) Fails or refuses to issue the performance security in accordance with the Instructions to Tenderers.

We undertake to pay to the Purchaser up to the above amount upon receipt of its first written demand, without the Purchaser having to substantiate its demand, provided that in its demand the Purchaser will note that the amount claimed by it is due it, owing to the occurrence of any one of the two above-named CONDITIONS, and specifying the occurred condition or conditions.

This guarantee will remain in full force up to and including **Monday 02nd June 2025**, and any demand in respect thereof must reach the Bank not later than the above date.

Note: A bidder who withdraws its tender after the deadline for submission will forfeit its bid security deposit

For and on behalf of the Bank

Signed: _____ Date: _____

Performance Bank Guarantee

To: _____ [Name of Client]
_____ [Address of Client]
_____ [Date]

Dear Sir,

WHEREAS _____ (hereinafter called “the Contractor”) has undertaken, in pursuance of Contract No. _____ dated _____ to execute _____ (hereinafter called “the Works”);

AND WHEREAS it has been stipulated by you in the said Contract that the Contractor shall furnish you with a Bank Guarantee by a recognized bank for the sum specified therein as security for compliance with his obligations in accordance with the Contract; AND WHEREAS we have agreed to give the Contractor such a Bank Guarantee:

NOW THEREFORE we hereby affirm that we are the Guarantor and responsible to you, on behalf of the Contractor, up to a total of Kshs. _____ (*amount of Guarantee in figures*) Kenya Shillings _____ (*amount of Guarantee in words*), and we undertake to pay you, upon your first written demand and without cavil or argument, any sum or sums within the limits of Kenya Shillings _____ (amount of Guarantee in words) as aforesaid without your needing to prove or to show grounds or reasons for your demand for the sum specified therein. We hereby waive the necessity of your demanding the said debt from the Contractor before presenting us with the demand.

We further agree that no change, addition or other modification of the terms of the Contract or of the Works to be performed thereunder or of any of the Contract documents which may be made between you and the Contractor shall in any way release us from any liability under this Guarantee, and we hereby waive notice of any change, addition, or modification.

This guarantee shall be valid until the date of issue of the Certificate of Completion.

SIGNATURE AND SEAL OF THE GUARANTOR

Name of Bank _____
Address _____
Date _____

Qualification Information

Individual Tenderers or Individual Members of Joint Ventures

1.1 Constitution or legal status of tenderer (attach copy or Incorporation Certificate);
Place of registration: _____

Principal place of business: _____

Power of attorney of signatory of tender: _____

1.2 Total annual volume of construction work performed in the last five years

Year	Volume	
	Currency	Value

1.3 Work performed as Main Contractor on works of a similar nature and volume over the last five years. Also list details of work under way or committed, including expected completion date.

Project name	Name of the client and contact person	Type of work performed and year of completion	Value of Contract

1.4 Major items of Contractor’s Equipment proposed for carrying out the Works. List all information requested below.

Item of Equipment	Description, Make and age (years)	Condition (new, good, poor) and number available	Owned, leased (from whom?), or to be purchased (from whom?)

1.5 Qualifications and experience of key personnel proposed for administration and execution of the Contract. Attach biographical data.

Position	Name	Years of experience (general)	Years of experience in proposed position

Project Manager etc.)			
-----------------------	--	--	--

1.6 Financial reports for the last TWO years: balance sheets, profit and loss statements, auditor's reports, etc. List below and attach copies.

1.7 Evidence of access to financial resources to meet the qualification requirements: cash in hand, lines of credit, etc. List below and attach copies of supportive documents.

1.8 Name, address and telephone numbers of banks that may provide reference if contacted by the Employer.

1.9 Statement of compliance with the requirements of Clause 1.2 of the Instructions to Tenderers.

1.10 Proposed program (work method and schedule) for the whole of the Works.

Joint Ventures

The information listed in 1.1 – 1.10 above shall be provided for each partner of the joint venture. The following information shall also be provided for the joint venture;

1. Attach the power of attorney of the signatory(ies) of the tender authorizing signature of the tender on behalf of the joint venture
2. Attach the Agreement among all partners of the joint venture (and which is legally binding on all partners), which shows that:
 - a) all partners shall be jointly and severally liable for the execution of the Contract in accordance with the Contract terms;
 - b) one of the partners will be nominated as being in charge, authorized to incur liabilities

and receive instructions for and on behalf of any and all partners of the joint venture;
and

- c) the execution of the entire Contract, including payment, shall be done exclusively with the partner in charge.

Confidential Business Questionnaire

You are requested to give the particulars indicated in part 1 and either part 2(a), 2(b), 2(c) or (2d) whichever applies to your type of business.
You are advised that it is a serious offence to give false information on this Form. (refer to clause 6.15)

Part 1 - General

Business Name:

Location of Business premises:

Country/Town.....

...

Postal Address:

Code: Town:

.....

Tel No.:

E-mail: Fax:

.....

Nature of Business:

.....

Part 2 (a) – Individuals

Your Name in full:

.....

Nationality: Country of Origin:

.....

Citizenship details:

.....

Part 2 (b) – Partnership

	Name	Nationality	Citizenship Details	Shares
1.
...				
2.
...				
3.
..				

Part 2 (c) – Registered Company

Private or Public:

.....

State the nominal and issue capital of the company.....

Nominal Kshs:

.....

Issued Kshs:

.....

Give details of all directors as follows:

	Name	Nationality	Citizenship Details	Shares
--	------	-------------	---------------------	--------

1.
...

2.
...

3.
...

Details of Sub-Contractors

If the Tenderer wishes to sublet any portions of the Works under any heading, he must give below details of the sub-contractors he intends to employ for each portion.

Failure to comply with this requirement may invalidate the tender.

1. Portion of Works to be sublet:

.....

Full names of the Sub-contractor:

.....

Address and head office:

.....

Sub-contractor's experience of similar Works carried out in the last 3 years with contract value:

.....

.....

.....

.....

.....

2. Portion of Works to be sublet:

.....

.....

.....

Full names of the Sub-contractor:

.....

Address and head office:

Sub-contractor's experience of similar Works carried out in the last 3 years with contract value:

.....

.....

.....

[Signature of Tenderer]

[Date]

Declaration

I/We have completed this form (s) accurately at the time of reply and it is agreed that all responses can be substantiated, if requested to do so, and that any inaccuracy in the information filled herein will lead to disqualification of the tenderer.

For and behalf of:

.....

Name:

.....

Date:

Signature

DETAILED SPECIFICATIONS

GENERAL ELECTRICAL SPECIFICATION

1. GENERAL

This section specifies the general requirement for plant, equipment and materials forming part of the contract Works and shall apply except where specifically stated elsewhere in the Specification or on the Contract Drawings.

1.1 Quality of Materials

All plant, equipment and materials supplied as part of the contract Works shall be new and of first class commercial quality, shall be free from defects and imperfections and where indicated shall be of grades and classifications designated herein.

All products or materials not manufactured by the contractor shall be products of reputable manufacturers and so far as the provisions of the Specification is concerned shall be as if they had been manufactured by the contractor.

Materials and apparatus required for the complete installation as called for by the Specification and Contract Drawings shall be supplied by contractor unless mention is made otherwise.

Materials and apparatus supplied by others for installation and connection by the Sub-contractor shall be carefully examined on receipt. Should any defects be noted, the contractor shall immediately notify the Engineer.

Defective equipment or that damaged in the course of installation or tests shall be replaced as required to the approval of the Engineer.

1.2 Regulations and Standards

The contract Works shall comply with the current editions of the following:

- a. The Kenya Government Regulations.
- b. The United Kingdom Institution of Electrical Engineers (IEE) Regulations for the Electrical Equipment of Buildings.
- c. The United Kingdom Chartered Institute of Building Services Engineers (CIBSE) Guides.
- d. British Standard and Codes of Practice as published by the British Standards Institution (BSI)
- e. The Local Council By-laws.
- f. The Electricity Supply Authority By-laws.
- g. Local Authority By-laws.
- h. The Kenya Building Code Regulations.
- i. The Kenya Bureau of Standards

1.3 Power Supply on Site

The supply voltage will be 240 volts single phase of 415 volts 3 phase 50 Hz. TN-S system, viz. separate neutral and protective conductor throughout the system.

2. INSTALLATION OF CABLES

2.1 General

Bending of cables shall be in accordance with table 52c of the IEE Regulations and no cable shall be bent to radius less than that specified by the cable manufacturers.

Cables shall be rated for the maximum connected load with due consideration to the following factors:-

- (i) Voltage drop not in excess of 4% of the nominal voltage.
- (ii) Ambient temperature.
- (iii) Degree of excess-current protection.
- (iv) Grouping.
- (v) Cables run under defined conditions.

2.2 Cables in conduits and Trunking

All cables shall be polyvinyl chloride (PVC) insulated to BS 6604, "PVC-insulated cables (non-armoured) for electric power lighting", 450/750 volt grade, unless an alternative is specified elsewhere in the contract documents. The quality and size of cables contained in any one conduit shall comply with IEE Regulation 529-7 and Appendix 12.

No cable with a cross-section area of less than 1.5mm² shall be used. All cables installed in a conduit or trunking system shall be PVC single insulated conductors and shall be colour coded in accordance with the IEE Regulation 524-3 and Table 52A.

Final sub-circuits shall be run in conduits separate from main or sub-main cables. All cables in conduit shall be drawn in simultaneously. All cables shall be drawn in without the use of excessive force, Without the use of lubricants and the wiring shall be easily withdrawable.

2.3 PVC/SWA/PVC Cable

These cables shall comprise copper conductors unless specifically detailed otherwise, laid up with PVC fillers bedded with an extruded inner PVC sheath, armoured with a single layer of galvanized steel wires, aluminium or strip as specified, and covered overall with PVC sheath.

Cables shall be manufactured to BS 6346 "PVC insulated cables for electrical supply" with conductor dimensions and resistances in accordance with BS 6360 1969, "copper conductors in insulated cables and cords", Armouring shall be galvanised steel to BS 1442.

Attention is drawn to Chapter 52 of the IEE Regulations and Appendix 9. Where the armour wires of cables are used to provide protective conductor they shall comply with the requirements of Chapter 54 of the IEE Regulations, particularly section 543; alternatively, additional cables with copper conductors shall be installed to reduce the impedance to a level which ensures compliance with Section 543 of the IEE Regulations.

The PVC/SWA/PVC cables should be terminated in the cable manufacturer's approved glands. These shall be of the compression type providing controlled radial compression of the sheath seal. The gland shall incorporate an armour clamping ring and earthing ring and, where used outdoors, a lead washer shall be used to ensure a watertight joint between the gland and the unit to which it is fitted. The earthing ring shall be rigidly fixed to the item of equipment and terminated using brass nuts, bolts and washers. All gland terminations shall be protected by a PVC shroud which shall fit tightly over the cables.

The electrical Contractor is responsible for determining the true nature and extent of cable routes. No claim on the grounds of lack of knowledge will be entertained. All cable routes shall be agreed with the Engineer. Cable joints shall be avoided especially for the main cables. In the event that they are unavoidable then proper connections or splices shall be used subject to engineer's approval. After the cables have been installed and terminated, but prior to putting into service, they shall be subjected to an insulation test of 500 volts and the results of these tests (recorded on test sheets) forwarded to the Engineer.

3. CONDUIT AND CONDUIT FACILITIES - MILD STEEL CONDUIT SYSTEM

3.1 Conduits

Conduits shall be installed as required by the IEE Regulations and as detailed in this specification. All metal conduits must be heavy gauge, seam welded, steel tube screwed conduits manufactured to BS 31, "steel tube screwed conduits and fittings for electrical wiring", Class B, BS 4568, "Steel conduit and fittings with thread of ISO form for electrical installation", for metric conduit, unless specified otherwise. Conduits shall be finished black stove enamelled, except in positions exposed to water (other than water used in construction), steam condensation or the action of weather, where hot galvanised conduits shall be used.

Any conduits work rejected by the Engineer shall be replaced at no extra cost. No conduit smaller than 20 mm in diameter or longer than 50mm diameter shall be used.

All bends in conduit shall be in accordance with the IEE Regulation 529-5, and made in a conduit bending machine fitted with a former of the correct radius for each conduit size.

Conduits shall be secured in an efficient pipe vice whilst being screwed. Conduit system shall be installed so as to ensure compliance with requirements of IEE Regulations 529-7. Attention is drawn to Appendix 12 of the IEE Regulations.

3.2 Conduit Fittings

Conduit fittings shall have same finish as the conduits being used and shall comply with BS 31 or BS 4586. All conduit fittings shall be screwed or loop-in malleable iron circular type, fitted with covers secured by brass screws. Rectangular adaptable steel boxes may be used on multi-conduit runs.

All circular type boxes must be fitted with long screwed spout conduit entries with the screwed thread terminating within the spout and the edges of the internal orifice of the box rounded and smoothed to act as a bush except for the adaptable steel rectangular boxes and loop-in conduit boxes, in which case male bush and coupling must be used for conduit connections. In concealed installation, boxes shall be fixed with the rims flush with the finished surface, but when, for any reason whatsoever, the rims are below the surface, suitable extension rings of the required depth shall be provided and installed to finish flush with the surrounding surfaces and with the lids of sufficient oversize (7.5 mm minimum all round) to cover the junction between box and plaster. In no case will the use of site-manufactured bends, sets, elbows, inspection elbows or tees be permitted.

3.3 Fixing of Conduits

All conduits must be firmly and rigidly fixed to be entirely without whip or movement. Space-bar saddles, or strap saddles, must be used on the timbers in roof spaces and will be allowed when the conduits are run on the underside of exposed unsealed floor or ceiling joints. Pipe hooks or crumpets will not be allowed except for security conduits in chases, or screeds, when the top of the hook must at least be 10 mm below the finished surface of the wall, or 25 mm below the floor finish. Pipe hooks shall be galvanised.

The finish of the saddles must in all cases conform to the finish of the supported conduits. Galvanised, sherardised or cadmium plated screws shall be used in all cases where galvanised conduits are installed.

The standard cast iron distance saddle, (single fixing base and two-screw fixing top), must be used for all conduits run on the surface of walls and ceilings etc., fixed at intervals of not more than 1.2 metres.

3.4 Conduit Runs and Concealment

The routes of the conduit installation shall be agreed with the Engineer prior to commencing the installation. Conduits shall be installed at least 150 mm from, and preferably under, any hot water pipes and at least 50 mm from other surface pipes and cables. Conduits shall be bonded to other surfaces in accordance with the requirements of IEE Regulations 413-2 and 547-4 to 547-7 inclusive.

Each continuity test shall be applied to the system before plastering, screeding, or casting of concrete is commenced. Surface work will be allowed where certain pre-fabricated methods of construction preclude the concealment of the runs, and or fair-faced brickwork or block work or other unplastered walls.

Conduit runs shall be planned to obviate the need for draw-in boxes, but where the use of such boxes is unavoidable they shall be accessible at all times and be fitted with covers. When Conduits are specified as being installed on the surface the runs must be arranged to render the whole system as neat and inconspicuous as possible, having regard to the existing architectural features. All vertical and horizontal runs must be taken where conduits converge and run together near distribution centres to obtain a symmetrical layout. The distance between the conduits shall be maintained through bends and sets and shall not vary noticeably.

3.5 Flexible Metallic Conduit

Flexible Conduit shall comply with the BS 731 part 1. "Flexible steel conduit and adaptors for the protection of electrical cables." It shall be used for the final connection from a rigid conduit installation to the terminal boxes of all the equipment provided with a means of positional adjustment and /or where vibration may reasonably be expected to occur.

Flexible conduits shall be PVC sheathed and shall be terminated using approved glands. In all instances a separate PVC insulated green and yellow coloured protective conductor complying with table 41A1 or 41A2 and section 543 of the IEE Regulations shall be installed, terminating at each end into purpose-made earthing terminals.

Under no circumstances will flexible conduits be accepted in lieu of sets and bends in a rigid conduit installation.

In normal circumstances flexible conduits shall have a minimum length of 300 mm and a maximum unstretched length of 800mm. It shall permit a full range of withdrawal, adjustment or movement of the equipment.

3.6 Locking, Bushing and Coupling

All conduit ends must be filed square and reamed before erection to ensure freedom from internal burrs and roughness.

Running couplings shall only be used on black enamelled steel conduit installations, and the use of this shall be kept to the minimum. All running couplings shall be secured by means of the lock nuts or lock rings, and the exposed thread painted after installation.

Every conduit connection to the equipment, boxes, distribution boards, loop-in boxes, cable trunking etc, shall be made by means of a screw coupling and a male hexagonal headed smooth bore brass bush. The smooth bore shall be fitted to secure the conduit to the item connected via a purpose-made clear hole to be closed by the bush and coupling when fitted. Paint must be removed from the surface of the item connected to allow it to be covered by the end of the coupling which shall be filed, clean and square, to ensure a good mechanical and electrical metal to metal joint. Any exposed area of metal from which paint has been removed must be made good in a matching paint. Bushes shall be fitted and tightened by means of correctly fitting spanners. Mutilated bushes damaged whilst being fitted must be removed and replaced.

Conduits connecting via couplings shall be connected by a means of 15 mm long threaded section and shall have a gap of approximately 2 mm between them. No thread shall be exposed except running couplings.

3.7 Continuity and Earthing

The whole of the conduit installations shall be mechanically and electrically sound and continuous throughout their length in accordance with the IEE Regulations.

Where the conduit system is used to provide a protective conductor it shall comply with the requirements of Chapter 54 of the IEE Regulations particularly Section 543; alternatively, a separate protective conductor shall be installed in the conduit to comply with Section 543 of the IEE regulations.

4. CABLE TRUNKING-SHEET STEEL

Trunking shall only be installed in situations which will remain readily accessible throughout the life of the buildings. No cable trunking shall be installed behind a plastered ceiling or in other inaccessible situations.

All cable trunking shall comply with BS 4678, part 1 "Steel surface trunking" and part 2 for "Steel underfloor (duct) trunking".

Sheet steel cable trunking may be used on installations employing steel conduits, for connecting two or more switchboards together or where several conduits would otherwise have to run alongside each other. Proper allowance should be made for the derating of cables installed together in a container system. The cables must be capable of carrying the current imposed by the equipment connected. Attention is drawn to Chapter 52 of the IEE Regulations, particularly Section 522, and Appendix 9: the current carrying capabilities of cables indicated shall not be exceeded. The Engineer must be consulted as to precise details concerning trunking routes and applications.

All lengths of trunking shall be heavy gauge zinc coated steel connected together by internally fitted rectangular couplings of sufficient width to provide a minimum bearing face of 25mm, to which the lengths shall be bolted on site or welded at the factory.

Adequate provision shall be made to allow for expansion.

All Tee pieces and bends shall be formed with similar means of connection and the inner radii area shall be such that cables will not be bent through a radius less than that prescribed in the IEE Regulations. Only bends and tees of approved pattern will be accepted.

All fixing screws within the trunking shall be of the round head type. The trunking shall have an over-lapping well-fitted lid securely fixed to the trunking by approved means that will avoid damage to the cables. Self-tapping screws shall not be used.

All necessary accessories including long sleeve couplings, end piece, bends, sets, tees, reducers, branches, fillets, pinracks, cable retainers etc., shall be purpose-made units rather than being fabricated on site.

Where a change in direction of trunking run occurs, the deviation should be effected by a purpose-made unit manufactured on similar lines to the bends and tee pieces described above. Where this is not practical, changes in direction shall be fabricated in a neat workmanlike manner. All joints shall fit closely and gaps will not be permitted. All burrs and sharp edges shall be removed and no screw shall protrude into the trunking.

Trunking shall be firmly attached to its associated equipment either by bolted flanges or by male bushes and couplings.

Where trunking is connected to equipment by means of flange connectors, the entry into the equipment shall be of the same cross-section as the trunking.

Where trunking does not terminate in equipment, the otherwise open end shall be capped with a cover suitable bolted in position.

Where communications, extra low voltage circuits (category 1) etc., are contained in a trunking, the requisite number of separate compartments shall be provided to segregate the wiring. Where conduits are taken off such trunking they shall not pass through other compartments unless prior permission is obtained from the Engineer.

The entire trunking is required to be recessed in the structure of the building, the finished edge of the trunking is to be installed flush with the plasterwork.

Trunking runs shall be so arranged that the lid or cover plate is always on the top or side and not underneath, unless this cannot be avoided, in which case the Engineer's permission shall be obtained.

Wherever trunking passes through walls, vertical partitions etc., a fixed piece of trunking lid shall be fitted to the trunking extended 25 mm either side of the wall or other barrier, this is to allow removal of the adjacent lid without disturbing the building fabric. Care shall be taken to ensure that no opening is left between the trunking and the building structure through which fire might spread. In addition, a suitable barrier of incombustible material shall be provided and fitted inside the trunking, in accordance with the IEE Regulations 528-1. On vertical runs of trunking internal incombustible barriers shall be fitted at the distance between floors or 5m, whichever is the less, in accordance with IEE Regulations 523-6.

All necessary trunking support work, hangers, brackets and fixing requirements shall be provided by the electrical Contractor.

Earth links of the appropriate size and type shall be installed at every jointing coupling, manufactured bend, etc., throughout the entire trunking system. Where trunking is used to provide a protective conductor, it shall comply with the requirements of Chapter 54 of the IEE Regulations, particularly Section 543; alternatively, a separate protective conductor shall be installed in the trunking to comply with section 543 of the IEE Regulations.

In cases where sheet steel trunking is installed and there is danger of movement, a flexible earth conductor shall be installed bonding all joints in the trunking. This shall be fitted in addition to the standard earth links. Cable retaining strips shall be fitted at 1 m intervals. Insulated cable support pins shall be fitted at intervals of 4 m in vertical runs of trunking and at the top of the vertical trunking.

5. CABLE TRAYS

Cable trays shall be formed from perforated steel of not less than 0.9 mm thickness up to and including 100 mm width - 1.25 mm thickness from 150 mm up to and including 300 mm width - and 2.00 mm thickness above 300 mm width. They shall be galvanised unless otherwise specified. Tray shall be adequately sized to support the cable without bunching.

Support shall be by means of steel brackets installed at intervals necessary to provide a rigid fixing and ensure that no undue deflection occurs in the complete installation. The brackets shall be

galvanised prior to fixing. Dome-headed bolts, nuts and washers of finish suitable to the tray shall be used between tray and brackets.

Fixing to the surfaces of walls, ceilings, etc. shall be by means of expansion-type masonry plugs or bolts. Fixings shall be galvanised unless otherwise stated. Cable trays shall be installed using factory-formed bends, elbows, tees, couplers and risers etc. Site fabrication of elbows etc., will only be permitted with prior approval of the Engineer and where it is not possible to obtain the necessary factory-made item.

Where cuts have been made, the tray shall be painted with zinc rich paint.

Holes which have been cut to allow cables to pass through shall be suitably bushed.

Suspension sets shall comprise threaded M12 cadmium plated hanger rods together with nuts and locking washers, vertical hanger brackets, support channel, tray hold-down clips etc., all of which shall have a galvanised finish.

All cables shall be securely fixed to tray work and the complete installation must be carried out in a neat and workmanlike manner without crossovers. A 25% reserve margin in size and weight shall be allowed for all cable tray works.

Cables of 30 mm diameter and above shall be fixed using the appropriate size cable straps of approved manufacture.

On light duty multi-cable runs, cable straps of plastic-coated metal shall be used to secure cables.

Bunching of cables will not be permitted.

Cables shall be clipped by means of copper or brass saddles and clips where high temperature or humid conditions are likely to be experienced. In all cases, saddles, clips, straps, etc., shall be fixed to the tray by means of brass screws or bolts and nuts.

6. PROTECTION OF PVC/SWA/PVC CABLES

6.1 General

Cable routing shall be such that the maximum degree of protection against accidental damage is obtained by running cables along the inside of channels and beams, etc.

Cables shall be laid in performed trenches or duct throughout all paved areas. Ducts shall be installed for underground cables before the paving is constructed.

Cable ducts shall be sealed at both ends using materials which are resistant to any likely corrosive and insect attack in the area concerned.

All cables rising through floors and trench covers, except in switch rooms, shall be protected by a length of steel pipe which shall project at least 150 mm above the finished surface level.

The open end of the pipe shall be sealed with a suitable compound. Care must be taken that all phases of single core cables pass through the same protective steel duct.

6.2 Cables Direct in Ground

All excavation and backfilling of cable trenches will be carried out by the main contractor unless otherwise specified, but the electrical Contractor shall in any case make sure that trenches are made to a depth as specified.

The electrical Contractor shall lay cables direct in the ground in the following manner:-

75 mm (3 inches) of dry fine sand shall be placed to form a bed for the cables. After cables have been laid they shall be covered with additional dry fine sand well punned over and around the cables to a level of 75 mm above the top of the uppermost cable. Mechanical punners shall not be used for this work. The electrical Contractor shall supply and install concrete cable tiles which shall be carefully placed over the cable forming each circuit.

Until all the cables have been laid in the trench and have been covered with their protective tiles, no sharp metal tools such as spades or fencing stakes, shall be used in the trench. Rollers used during laying of cables shall have no sharp projecting parts liable to damage the cables.

6.3 Cables above Ground

For main cable runs the cable shall be run on approved tray or ladder rack, and secured to it at intervals of not more than 400 mm horizontally and 600 mm vertically.

Cables shall be dressed together and fixed with a common saddle. If the number of cables is such as to require the tiering of cables, the number of tiers shall generally be two.

7. TERMINATION OF CABLES

Cables shall be terminated in accordance with Chapter 52 of the IEE Regulations, particularly Section 527.

Cables shall be terminated by one of the following methods:-

- (i) The cable conductors shall be sweated into lugs of the appropriate size for the cable and equipment terminal.
- (ii) The cable conductors shall be secured by compression type lugs of the correct size for the cable and equipment terminal.
- (iii) The cable conductors shall be secured in pinch screw terminals.
- (iv) The cable shall be secured by means of clamps.

Where cables are required to terminate at connectors, as at lighting points, such connectors shall secure all the strands of stranded cables. Care shall be taken to ensure that cables are not damaged during preparation for termination.

Cables terminating at pinch screw terminals shall be twisted together and single cables shall have the conductor doubled back to ensure adequate purchase for pinching screws.

Cables connected to lamp holders or other components at which heat is produced shall be insulated with heat resisting material capable of withstanding, without detriment, the temperature encountered.

All terminations on PVC/SWA/PVC insulated cables shall be by compression type glands of an approved design and manufacture with facilities for clamping the armouring the outer sheath of the cable.

Glands mounted outdoors shall incorporate a seal to prevent ingress of moisture into the gland, and all glands shall be fitted with a thermoplastic shroud.

Where circular terminations are to be made, these shall be completed using Ross Counterney terminals.

Where cables are terminated in "Klippon" type terminals with parallel faced jaws, the individual cores shall be terminated using the appropriate flat or hook blade crimped lugs. Where the terminal faces are concaved, the cores shall be terminated in wires pin crimped lugs.

The electrical Contractor shall avoid multiple connections under one screw or one pin. Where more than two wires are required, a common termination jumper bar shall be used.

Terminals shall be mounted on rails or supports. All internal wiring is to be clearly marked by markers.

8. SEGREGATION OF SERVICES

Cables of differing voltages shall be segregated so that there is no possibility of a fault in a power cable damaging any adjacent cables or imposing a different voltage upon them.

9. IDENTIFICATION OF CABLES

All cables shall be fitted with non-corrosive cable identification bands at each end, and at all changes of direction where they leave a group of cables. All cables cores connected to equipment having marked terminals shall be fitted with non-corrosive identification bands bearing markings corresponding to those of the terminals at both ends.

10. CONTROL PANELS AND CUBICLES

The details specified in IEEE Regulations shall apply as far as fused switches, bus-bars and rating etc are concerned. The panels shall be constructed from rolled steel channel minimum size 60 mm x 30 mm deep x 5 mm or equivalent angle section clad with sheet steel of 3 mm gauge. 2 mm gauge may be used for covers and doors of not more than 1 m square.

Terminals shall be of the "Klippon" standards rail-mounted feed-through type or approved equal. All terminals shall be identified by means of numbered or lettered marking tags, which shall be identical to the number of letter applied to the cables. Cables shall be identified as terminations by means of cable markers as manufactured by "Klippon" or approved equal. 25% spare terminals capacity within wiring duct shall be provided. All components motors, starters, relays, timers, etc. shall be labelled showing their reference and function and these shall relate to the panels' schematic wiring diagram provided with the "As-built" drawing and manuals.

All control panels shall be fitted with multi-pole isolating switches through which all electricity supplies shall pass. The door(s) of the control panel shall not open unless the isolating switch is in

the "off" position. A facility to lock the control panel-isolating switch in the "off" position shall be included.

11. DISTRIBUTION BOARDS

11.1 General

All distribution boards, unless stated otherwise, shall be miniature Circuit Breaker Distribution Boards and shall be of surface or flush type, as specified. Facilities for local isolation of the distribution boards shall be provided by either a local fused-switch unit or an integral isolating switch, whichever is specified.

Where surface mounted on a flush installation, all conductors shall terminate behind the board in an adequate box. For surface mounting, trunking shall be fixed between the board and ceiling level, or conduits run directly into the board. Adequate earth continuity connection shall be made between the various components.

11.2 Miniature Circuit-Breaker Distribution Boards

MCB distribution boards shall comply with BS. 5486 part 12 'Particular requirements for miniature circuits-breaker boards'. The cases shall be constructed of heavy gauge sheet steel, in such a manner as to afford rigidity and maximum ease of wiring for full size circuit and main cables.

The cover shall be provided with an efficient gasket or alternatively designed with generous overlapping edges to prevent the ingress of dust. Components shall not be manufactured from zinc alloy in conjunction with sheet steel where they are relied upon for earth continuity.

Where the cover is required to be lockable, cylinder type locks shall be provided, having two keys per lock. All locked distribution boards shall be handed to the Engineering Supervisor on completion of the works. The cases shall be provided with detachable cable/conduit terminating plates, which shall be reversible and interchangeable from top to bottom.

All screws and nuts used in the construction of the case shall be fitted with shake proof washers and care taken to ensure efficient earth continuity. An external earthing terminal with cable socket shall be fitted.

All MCB banks shall be fitted to frames, with robust locking plates provided to ensure the frames rigidly in the fixed position.

The banks shall be so spaced to obviate the necessity for insulating barriers, but protection shall be provided by means of insulating shields to prevent accidental contact with main bus bars and incoming mains cable.

Bus-bars shall be of high conductivity, hard drawn copper conductors connected to the MCB contacts by means of spring washered screws or bolts, unless plug-in type MCBs are specified.

Neutral bars shall be similar to the main bus bars and shall have two screw terminals per way for rating of 30 amps or over. Single screw connections will be allowed for capacities up to 30 amps. The neutral bars shall have one terminal for each MCB within the board, and connection of conductors to the neutral bar shall be in the same order as the MCB ways.

Where installations are carried out with cables with a protective conductor, all distribution boards shall also contain internal earthing bars similar to the neutral bars detailed above, with one terminal for each MCB within the board. Earthing conductors shall be connected in the manner described for neutral conductors to neutral bars.

Where a main integral isolating switch is provided in an MCB case it shall be arranged to isolate incoming live and neutral main cables from the bus-bars. The isolator switch shall be rated at 500 volts and of the quick make-and break pattern with positive action. Incoming and outgoing terminals shall be fitted with two clamping screws and outgoing conductors to the bus-bars shall be high conductivity hard drawn copper rods.

Isolating switches shall comply with IEE Regulations, Part 537, and shall be capable of carrying their full rated load continuously and shall 'make' or 'break' their full rated load without undue burning of the contacts.

11.3 Miniature Circuits Breaker (MCB)

All MCBs shall have movements which are positive in both directions (make and break) so as to enable units to be closed decisively by the operation of the handle, and to be able to assume the 'OFF' position unless the contacts are definitely separated, to safeguard against false indications.

The handle shall be trip free to make it impossible for the operator to hold the breaker in the closed position under faulty conditions. The operating mechanism and arc chambers of the circuit breaker shall be separated from the terminals and fixing screws.

Terminal identification shall be readily discernable as viewed from the front of the board with automatic and clear signal identification for both 'ON' and 'OFF' position.

All terminals shall be readily accessible from the front and each wiring chamber shall be closed by a screw fixed cover which protects the terminals and prevents dust from settling on the insulation.

Where the full capacity of a distribution board is not required the electrical Contractor shall fix blanking plates in the vacant MCB housings. All MCBs shall be rated at 500 volts minimum, and comply with BS 3871. "Miniature and moulded case circuits breakers" and 4752 part 1, "Circuit breakers".

11.4 Moulded Case Circuit Breakers (MCCB)

Where specified, MCCBs shall be of the thermal/magnetic type, having a quick make, quick break, trip free mechanism which prevents the MCCB from being closed or held against short circuits or overloads. Tripping of every multi-pole MCCB shall be such that operation ensures simultaneous action in all phases.

Clear indication shall be provided for the three positions of operation of the mechanism - 'ON', 'OFF' and 'TRIPPED'. The operation shall be such that the MCCB shall trip automatically under fault conditions and, to reset, the handle shall require first moving through the 'off' position. All MCCBs shall be provided with facilities for locking the breaker in 'OFF' position.

All MCCBs shall be rated at 500 volts minimum, be ASTA certified for this operational duty, and comply with BS. 3871 and BS. 4752 Part 1.

12. **MAIN DISTRIBUTION PANEL (SEE SCHEMATIC DIAGRAMS)** as specified in the specific facility BoQ
13. **Auxilliary components: (as specified in the specific facility BoQ)**
 - a. **Energy Meter**
Set of neon phase presence indicator lamps
 - b. Type C Curve MCCB incomer
 - c. Sealable studs for all cover plate screws and all necessary accessories
 - d. 6mm perspex viewing window complete with Heavy duty rubber lining
 - e. 415V three-phase surge diverter as Furse ESP 415, wired as shown, complete with enclosure with viewing window.
 - f. KPLC Meter chamber,
 - g. Cutout Fuses chamber
 - h. Comprehensive Labelling of all the bus bars. CT chambers, circuit breakers etc. of the above items, indicating the areas served, outgoing cable sizes etc.
14. **Earthing/Grounding (as specified in the specific facility BoQ)**
15. **PSA Planthouse Main Panel (See Schematic Diagrams) (as specified in the specific facility BoQ)**
16. **Cables and Cable handling materials (as specified in the specific facility BoQ)**
17. **Automatic voltage regulator (as specified in the specific facility BoQ)**

18. LABELLING AND ENGRAVING

18.1 Labelling

All fused-switch units, switch-fuses, switches, bus-bars chambers, distribution boards etc., and all items of equipment on the main panel shall be identified in accordance with section 514 of the IEE Regulations and shall have securely fitted externally a white 'Traffolyte', 'Formica' or other approved plastic laminate label engraved with 6 mm high black letters detailing the function of the equipment and any reference number.

Red, yellow, blue, plastic laminate phase discs shall be fixed inside all switchgear and distribution boards to indicate to which phase of the supply the various circuits are connected. The colourings shall comply with Part 524 of the IEE Regulations.

Each TP or TP & N item of switchgear shall have fitted on the cover a white plastic laminate label having 'CAUTION' - 415 VOLTS' engraved in 10 mm high red lettering.

18.2 Engraving

The electrical Contractor shall allow for engraving of all switched fused spurs, double pole switch accessories and any other accessories, which are customarily required.

The accessory plate shall be engraved in either black or red, capital letters 5 mm high, detailing and appliance or equipment being supplied by the accessory e.g., 'WATER PUMP' etc.

19. INSPECTION AND TESTING

A visual inspection shall be made in accordance with IEE Regulations 612-1. References shall be made to appendix 14 of the IEE Regulations, which is a checklist for initial inspection of installations.

The electrical installation shall be inspected and tested by the electrical Contractor in accordance with part 6 of the IEE Regulations.

Where any part of installation is to be concealed within a building, fabric tests shall be made to ensure that the installation is satisfactory prior to concealment.

Upon completion of the works the whole installation shall be subjected to the tests detailed hereafter and every defect shall be noted, corrected and brought to the notice of the Engineer.

All tests shall be witnessed by the Engineer to his full satisfaction and he shall be given at least one week's notice in writing of the proposed tests.

All labour and test instruments shall be provided by the electrical Contractor and the instruments shall be correctly calibrated and certified for the limits of accuracy required and shall be operated by competent person. If, in the Engineer's opinion, a particular instrument is not suitable, then an acceptable alternative shall be provided. The Engineer shall be at liberty to demand the use of any testing instrument or apparatus that he may reasonably consider to be necessary in the execution of the testing.

In the event of the installation failing to pass the test, the Engineer has the full authority of the Employer to deduct from the Contract Price all reasonable expenses incurred, due to him being required to attend a repetition of the test.

The following items, where relevant, shall be tested in the sequence indicated. Standard methods of testing, in respect of some of the following regulations of this section, are given in Appendix 15 of the IEE Regulations.

- i) Continuity of ring final circuit conductors.
- ii) Continuity of protective conductors, including main supplementary equipotential bonding.
- iii) Earth electrode resistance.
- iv) Insulation resistance.
- v) Insulation of site-built assemblies.
- vi) Protection of barriers or enclosures provided during erection.
- vii) Insulation of non-conducting floors and walls.
- viii) Polarity.
- ix) Earth fault loop impedance.
- x) Operation of residual current devices and fault voltage operated protected devices.

Upon completion of all tests and commissioning, two copies of detailed certificates shall be provided by the electrical Contractor to show that the equipment, materials, installation etc., have

been tested and commissioned. One copy of each, duly completed and signed shall be submitted to the Engineer within 154 days of the results being obtained. The second copy of the certificates shall be retained to be included with operator and maintenance manuals.

The results of the test and details of completion for the electrical test shall be detailed on the Test and Completion Certificates respectively; issued by the National Inspection council for Electrical Installation Contracting or other approved authority.

20. AS BUILT DRAWINGS, AND DOCUMENTATION

Within one month of the date of completion the electrical contractor shall provide 3 prints of all electrical drawings showing the electrical installations "As built" and a soft copy. In case the electrical Contractor fails to provide "As Built" drawings as required, these will be prepared by others at the expense of the electrical contractor:

PART B: FINANCIAL

(BILLS OF QUANTITIES)

(It should be noted that the information provided in this BOQ regarding cable lengths and panel dimensions, number of fittings and other specific details should be considered as approximate and indicative only. Amref shall maintain responsibility for primary definition of the scope and the governing standards for design, whereas the final design and specific details and quantities of the BOQ shall be the responsibility of the bidding contractor.)

LOT SUMMARY - LOT 4

S/No.	Facility/Site	Cost for Electrical Works	Total Amount (KSH)
1	Elwak District hospital		
2	Mandera County Hospital		
3	Sololo Sub County Hospital		
TOTAL COST FOR ALL WORKS IN LOT 4 (Carried to FORM OF TENDER)			



PROPOSED ELECTRICAL INSTALLATION
WORKS

BILLS OF QUANTITIES

Bill of Quantities for the Electrical Installation: Elwak

Last Updated: 13 November 2024



Item	Description	Unit	Qty	Rate	Amount (KShs)
	<p><i>Note: The work under this element is to be carried out by a registered electrical subcontractor (EPRA Class B and above).</i></p> <p>Supply, install test and commission in accordance to BS 7671:1998, the following as described below:</p> <p>1No. 80A 3P Type C Curve MCCB outgoer, with 25kA short circuit breaking capacity. (Installed in the Existing Main Panel Non-Maintained Busbar, Supplying To PSA Plant Feeder Panel)</p>	No.	1		
	<p>EARTHING/GROUNDING</p> <p>Comprehensive protective multiple earthing in 1800mm long 16mm diameter pure electrolytic copper earth rod deep driven to permanent moisture level, copper clamp. 70mm² green earth lead complete with all accessories. (Note: Use parallel rods if effective earthing cannot be achieved with 1 No. rod).</p>	Item	1		
	<p>Trenching, removal of earth, sifting of the soil, laying duct for the underground cables, covering with fine sand, laying underground Feeder Warning Ribbon/Hatari Tiles, backfilling, and compacting to natural ground level as per trenching details</p>	m.	154		
	<p>PSA PLANT HOUSE MAIN PANEL (SEE SCHEMATIC DIAGRAMS)</p> <p>Factory made and factory assembled 125A, IP65, TPN Main Panel for power distribution to the plant container, manufactured in 14SWG galvanised steel sheet and finished in cream (or appropriate colour) powder coating, complete with the following:-</p> <p>i) 1No. 80A 3P Type C Curve MCCB incomer, with 10kA short circuit breaking capacity.</p> <p>ii) 5 No. 125A TPN+E insulated copper bus bars</p> <p>iii) 1No. 63A 3P Type C Curve MCCBs outgoer, with 10kA short circuit breaking capacity to PSA container.</p> <p>iv) 1No. 63A 1P Type D Curve MCCB outgoer, with 10kA short circuit breaking capacity to Plant House CU.</p> <p>v) 1No. 32A 3P and 1 No 63A 1P Type D Curve MCCB spares, with 10kA short circuit breaking capacity.</p> <p>vii) Sealable studs for all cover plate screws and all necessary accessories</p> <p>viii) Comprehensive Labelling of all the bus bars. CT chambers, circuit breakers etc. of the above items, indicating the areas served, outgoing cable sizes etc.</p> <p>(NB: The Entire Plant House Panel to be priced as an Item)</p> <p>Shop Drawings shall be submitted for approval prior to fabrication.</p>	Item	1		

BILLS OF QUANTITIES FOR ELECTRICAL INSTALLATIONS

5	Provide and install 35mm ² 4 core XLPE/SWA/PVC/CU + 25mm ² ECC CU Conductor, from the Feeder Pillar to the PSA Plant House Main Panel.	LM	140		
a)	Cable Glands	No.	4		
b)	Cable Lugs	No.	10		
<u>CABLE LADDERS/TRAYS</u>					
6	150 x 50mm super heavy gauge galvanized steel perforated cable tray for support of cables complete with cable ties, junctions, corner elbows, supporting brackets and supporting frame. (provisional)	m	40		
Total For Power Supply and Distribution Caried Forward to Summary Page					

BILLS OF QUANTITIES FOR ELECTRICAL INSTALLATIONS

Item	Description	Unit	Qty	Rate	Amount (KShs)
	AUTOMATIC VOLTAGE REGULATOR				
7	Automatic voltage regulator with the following characteristics:- - Rating: 60KVA, - Power Supply: 3 phase, 415/240V, - Operation: independent phase control - Regulator overload protection. - Input Voltage Tolerance: 20% i.e. from 365-505V 3 Phase, from 192-288V 1 Phase - Frequency: 50Hz - Output voltage accuracy: +/- 1% - Ambient Temperature: -25 - 45 0 C, - Efficiency: 98% - Maximum Relative Humidity : 90%, - Warranty: Not less than 2 Years - Bypass: Auto/Manual operation - Admitted Overload : 200% for 2 minutes. - Harmonic Distortion Free - Protection Degree : IP21 - State Dimensions of the AVR (WxDxH), Weight (KGS), Make and Country of Origin of AVR - Cooling: Natural but fan assisted above 35 0C - Overvoltage protection : Class 1 input surge arrestors, class II output surge arrestors	Item	1		
8	80A 4P MCCBs Incomer, with both adjustable thermal and magnetic trip units and with 16kA short circuit breaking capacity.	No	1		
9	100A TPN Manual by-pass system across the AVR to be complete with 2 No 100A TPN Manual change over switches and incorporated in the above-mentioned PSA Plant House Main Panel	Item	1		
10	Provide and install 35mm ² 4 core XLPE/SWA/PVC/CU + 25mm ² ECC CU Conductor, to and from the AVR	LM	15		
a)	Cable Glands	No.	4		
b)	Cable Lugs	No.	10		
	Total for Automatic Voltage Regulator Caried Forward to Summary Page				

BILLS OF QUANTITIES FOR ELECTRICAL INSTALLATIONS

Item	Description	Unit	Qty	Rate	Amount (KShs)
	PRELIMINARIES AND GENERAL ITEMS				
11	Acquire and submit Insurance for the sub-contract work.	Item	1		
12	Allow for presentation of all the required samples as per specifications, Bills of Quantities and Drawings.	Item	1		
13	Allow for carrying out comprehensive testing of the installation as per IEC standards, User training	Item	1		
14	Carry out very concise and comprehensive load balancing of PSA Plant Sub-Board to achieve a maximum imbalance not greater than $\pm 10\%$ between any two phases.	Item	1		
15	Allow for Liaison with Kenya Power for upgrade of the utility transformer and cabling infrastructure to accommodate the increased demand. This shall also include relocation of the existing Kenya Power kWh meter from the existing location to the new MDP.	Item	1		
16	Allow for the disconnection, removal, handing over to the client against an approved inventory, any existing items on site related to PSA plant installation.	Item	1		
	Total for Preliminaries and General Items Caried Forward to Summary Page				

BILLS OF QUANTITIES FOR ELECTRICAL INSTALLATIONS

Item	Description				Amount (KShs)
MAIN SUMMARY PAGE					
S1	Total for Power Supply and Distribution Brought Forward				
S2	Total for Automatic Voltage Regulator Brought Forward				
S3	Total for Preliminaries and General Items				
S4	Subtotal				
S5	Allow 10% of Subtotal Above for Contingency	Item			
Total for ELECTRICAL INSTALATION WORKS					
Add 16% VAT					
Total for ELECTRICAL INSTALATION WORKS (incl VAT) Carry to Lot Summary Page					

Bill of Quantities for the Electrical Installation: Manderu

Last Updated: 13 November 2024



Item	Description	Unit	Qty	Rate	Amount (KShs)
	<p><i>Note: The work under this element is to be carried out by a registered electrical subcontractor (EPRA Class B and above).</i></p> <p>Supply, install test and commission in accordance to BS 7671:1998, the following as described below:</p>				
1	<p>1No. 150A 3P Type C Curve MCCB outgoing, with 15kA short circuit breaking capacity. (Installed in the Existing Main Panel, Supplying To PSA Plant Feeder Panel)</p>	No.	1		
	<p>EARTHING/GROUNDING</p> <p>Comprehensive protective multiple earthing in 1800mm long 16mm diameter pure electrolytic copper earth rod deep driven to permanent moisture level, copper clamp. 70mm² green earth lead complete with all accessories. (Note: Use parallel rods if effective earthing cannot be achieved with 1 No. rod).</p>	Item	1		
3	<p>Trenching, removal of earth, sifting of the soil, laying duct for the underground cables, covering with fine sand, laying underground Feeder Warning Ribbon/Hatari Tiles, backfilling, and compacting to natural ground level as per trenching details</p>	m.	110		
	<p>PSA PLANT CONTAINER FEEDER PILLAR PANEL (SEE SCHEMATIC DIAGRAMS)</p> <p>Factory made and factory assembled 200A, IP65, TPN Main Panel for power distribution to the plant container, manufactured in 14SWG galvanised steel sheet and finished in cream (or appropriate colour) powder coating, complete with the following:-</p>				
4	<p>1 No. Digital energy meters capable of measuring voltage in the range 0 – 1000V, 3-phase, current in the range 0-200A, 3-phase, and all power system parameters (KW, KVA, KWHr, KVAr, i) Frequency, P.F., harmonics and all the parameters). The energy meter to have an accessible terminal for connecting an external printer, and should be complete with selector switches for viewing/displaying the various parameters.</p>				
ii)	<p>1No. 150A 3P Type C Curve MCCB incoming, with 25kA short circuit breaking capacity.</p>				
iii)	<p>5 No. 200A TPN+E insulated copper bus bars</p>				
iv)	<p>1No. 125A 3P Type C Curve MCCBs outgoing, with 25kA short circuit breaking capacity.</p>				
v)	<p>1No. 63A 1P Type D Curve MCCB outgoing, with 25kA short circuit breaking capacity.</p>				
vi)	<p>1No. 20A TP and 1 No 63A 3P Type D Curve MCCB spares, with 10kA short circuit breaking capacity.</p>				
vii)	<p>Sealable studs for all cover plate screws and all necessary accessories</p>				
ix)	<p>Comprehensive Labelling of all the bus bars. CT chambers, circuit breakers etc. of the above items, indicating the areas served, outgoing cable sizes etc.</p>	Item	1		

BILLS OF QUANTITIES FOR CONTAINERISED PSA SHELTER

	<p>(NB: The Entire Plant House Panel to be priced as an Item) Shop Drawings shall be submitted for approval prior to fabrication.</p>				
5	<p>Provide and install 95mm² 4 core XLPE/SWA/PVC/CU + 50mm² ECC CU Conductor, from the Main Panel to the PSA Plant House Panel.</p>	LM	100		
a)	Cable Glands	No.	4		
b)	Cable Lugs	No.	10		
	<p><u>CABLE LADDERS/TRAYS</u></p>				
6	<p>150 x 50mm super heavy gauge galvanized steel perforated cable tray for support of cables complete with cable ties, junctions, corner elbows, supporting brackets and supporting frame. (provisional)</p>	m	40		
	<p>Total For Power Supply and Distribution Caried Forward to Summary Page</p>				

BILLS OF QUANTITIES FOR CONTAINERISED PSA SHELTER

Item	Description	Unit	Qty	Rate	Amount (KShs)
	AUTOMATIC VOLTAGE REGULATOR				
7	Automatic voltage regulator with the following characteristics:- - Rating: 100KVA, - Power Supply: 3 phase, 415/240V, - Operation: independent phase control - Regulator overload protection. - Input Voltage Tolerance: 20% i.e. from 365-505V 3 Phase, from 192-288V 1 Phase - Frequency: 50Hz - Output voltage accuracy: +/- 1% - Ambient Temperature: -25 - 45 0 C, - Efficiency: 98% - Maximum Relative Humidity : 90%, - Warranty: Not less than 2 Years - Bypass: Auto/Manual operation - Admitted Overload : 200% for 2 minutes. - Harmonic Distortion Free - Protection Degree : IP21 - State Dimensions of the AVR (WxDxH), Weight (KGS), Make and Country of Origin of AVR - Cooling: Natural but fan assisted above 35 0C - Overvoltage protection : Class 1 input surge arrestors, class II output surge arrestors	Item	1		
8	150A 4P MCCBs Incomer, with both adjustable thermal and magnetic trip units and with 16kA short circuit breaking capacity.	No	1		
9	200A TPN Manual by-pass system across the AVR to be complete with 2 No 160A TPN Manual change over switches and incorporated in the above-mentioned PSA Plant House Main Panel	Item	1		
10	Provide and install 95mm ² 4 core XLPE/SWA/PVC/CU + 50mm ² ECC CU Conductor, to and from the AVR	LM	15		
a)	Cable Glands	No.	4		
b)	Cable Lugs	No.	10		
	Total for Automatic Voltage Regulator Caried Forward to Summary Page				

BILLS OF QUANTITIES FOR CONTAINERISED PSA SHELTER

Item	Description	Unit	Qty	Rate	Amount (KShs)
	PRELIMINARIES AND GENERAL ITEMS				
11	Acquire and submit Insurance for the sub-contract work.	Item	1		
12	Allow for presentation of all the required samples as per specifications, Bills of Quantities and Drawings.	Item	1		
13	Allow for carrying out comprehensive testing of the installation as per IEC standards, User training	Item	1		
14	Carry out very concise and comprehensive load balancing of PSA Plant Sub-Board to achieve a maximum imbalance not greater than $\pm 10\%$ between any two phases.	Item	1		
15	Allow for Liaison with Kenya Power for upgrade of the utility transformer and cabling infrastructure to accommodate the increased demand. This shall also include relocation of the existing Kenya Power kWh meter from the existing location to the new MDP.	Item	1		
16	Allow for the disconnection, removal, handing over to the client against an approved inventory, any existing items on site related to PSA plant installation.	Item	1		
	Total for Preliminaries and General Items Caried Forward to Summary Page				

BILLS OF QUANTITIES FOR CONTAINERISED PSA SHELTER

Item	Description				Amount (KShs)
MAIN SUMMARY PAGE					
S1	Total for Power Supply and Distribution Brought Forward				
S2	Total for Automatic Voltage Regulator Brought Forward				
S3	Total for Preliminaries and General Items				
S4	Subtotal				
S5	Allow 10% of Subtotal Above for Contingency	Item			
Total for ELECTRICAL INSTALATION WORKS					
Add 16% VAT					
Total for ELECTRICAL INSTALATION WORKS (incl VAT) Carry to Lot Summary Page					

Bill of Quantities for the Electrical Installation: Sololo

Last Updated: 13 November 2024



Item	Description	Unit	Qty	Rate	Amount (KShs)
	<p><i>Note: The work under this element is to be carried out by a registered electrical subcontractor (EPRA Class B and above).</i></p> <p>Supply, install test and commission in accordance to BS 7671:1998, the following as described below:</p>				
1	<p>1No. 80A 3P Type C Curve MCCB outgoer, with 25kA short circuit breaking capacity. (Installed in the Existing Main Panel Non-Maintained Busbar, Supplying To PSA Plant Feeder Panel)</p>	No.	1		
	<p>EARTHING/GROUNDING</p>				
2	<p>Comprehensive protective multiple earthing in 1800mm long 16mm diameter pure electrolytic copper earth rod deep driven to permanent moisture level, copper clamp. 70mm² green earth lead complete with all accessories. (Note: Use parallel rods if effective earthing cannot be achieved with 1 No. rod).</p>	Item	1		
3	<p>Trenching, removal of earth, sifting of the soil, laying duct for the underground cables, covering with fine sand, laying underground Feeder Warning Ribbon/Hatari Tiles, backfilling, and compacting to natural ground level as per trenching details</p>	m.	20		
	<p>PSA PLANT HOUSE MAIN PANEL (SEE SCHEMATIC DIAGRAMS)</p>				
4	<p>Factory made and factory assembled 125A, IP65, TPN Main Panel for power distribution to the plant container, manufactured in 14SWG galvanised steel sheet and finished in cream (or appropriate colour) powder coating, complete with the following:-</p>				
i)	<p>1No. 80A 3P Type C Curve MCCB incomer, with 10kA short circuit breaking capacity.</p>				
ii)	<p>5 No. 125A TPN+E insulated copper bus bars</p>				
iii)	<p>1No. 63A 3P Type C Curve MCCBs outgoer, with 10kA short circuit breaking capacity to PSA container.</p>				
iv)	<p>1No. 63A 1P Type D Curve MCCB outgoer, with 10kA short circuit breaking capacity to Plant House CU.</p>				
v)	<p>1No. 32A 3P and 1 No 63A 1P Type D Curve MCCB spares, with 10kA short circuit breaking capacity.</p>				
vi)	<p>415V three-phase surge diverter as Furse ESP 415, wired as shown, complete with enclosure with viewing window.</p>				
vii)	<p>Sealable studs for all cover plate screws and all necessary accessories</p>				
ix)	<p>Comprehensive Labelling of all the bus bars. CT chambers, circuit breakers etc. of the above items, indicating the areas served, outgoing cable sizes etc.</p>				
	<p>(NB: The Entire Plant House Panel to be priced as an Item)</p>				

BILLS OF QUANTITIES FOR CONTAINERISED PSA SHELTER

	Shop Drawings shall be submitted for approval prior to fabrication.	Item	1		
5	Provide and install 35mm ² 4 core XLPE/SWA/PVC/CU + 16mm ² ECC CU Conductor, from the MDP to the PSA Plant house panel.	LM	20		
a)	Cable Glands	No.	4		
b)	Cable Lugs	No.	10		
	<u>CABLE LADDERS/TRAYS</u>				
7	150 x 50mm super heavy gauge galvanized steel perforated cable tray for support of cables complete with cable ties, junctions, corner elbows, supporting brackets and supporting frame. (provisional)	m	40		
	Total For Power Supply and Distribution Caried Forward to Summary Page				

BILLS OF QUANTITIES FOR CONTAINERISED PSA SHELTER

Item	Description	Unit	Qty	Rate	Amount (KShs)
	AUTOMATIC VOLTAGE REGULATOR				
8	Automatic voltage regulator with the following characteristics:- - Rating: 60KVA, - Power Supply: 3 phase, 415/240V, - Operation: independent phase control - Regulator overload protection. - Input Voltage Tolerance: 20% i.e. from 365-505V 3 Phase, from 192-288V 1 Phase - Frequency: 50Hz - Output voltage accuracy: +/- 1% - Ambient Temperature: -25 - 45 0 C, - Efficiency: 98% - Maximum Relative Humidity : 90%, - Warranty: Not less than 2 Years - Bypass: Auto/Manual operation - Admitted Overload : 200% for 2 minutes. - Harmonic Distortion Free - Protection Degree : IP21 - State Dimensions of the AVR (WxDxH), Weight (KGS), Make and Country of Origin of AVR - Cooling: Natural but fan assisted above 35 0C - Overvoltage protection : Class 1 input surge arrestors, class II output surge arrestors	Item	1		
9	80A 4P MCCBs Incomer, with both adjustable thermal and magnetic trip units and with 16kA short circuit breaking capacity.	No	1		
10	100A TPN Manual by-pass system across the AVR to be complete with 2 No 100A TPN Manual change over switches and incorporated in the above-mentioned PSA Plant House Main Panel	Item	1		
11	Provide and install 35mm ² 4 core XLPE/SWA/PVC/CU + 25mm ² ECC CU Conductor, to and from the AVR	LM	15		
a)	Cable Glands	No.	4		
b)	Cable Lugs	No.	10		
	Total for Automatic Voltage Regulator Caried Forward to Summary Page				

BILLS OF QUANTITIES FOR CONTAINERISED PSA SHELTER

Item	Description	Unit	Qty	Rate	Amount (KShs)
	PRELIMINARIES AND GENERAL ITEMS				
12	Acquire and submit Insurance for the sub-contract work.	Item	1		
13	Allow for presentation of all the required samples as per specifications, Bills of Quantities and Drawings.	Item	1		
14	Allow for carrying out comprehensive testing of the installation as per IEC standards, User training	Item	1		
15	Carry out very concise and comprehensive load balancing of PSA Plant Sub-Board to achieve a maximum imbalance not greater than $\pm 10\%$ between any two phases.	Item	1		
16	Allow for Liaison with Kenya Power for upgrade of the utility transformer and cabling infrastructure to accommodate the increased demand. This shall also include relocation of the existing Kenya Power kWh meter from the existing location to the new MDP.	Item	1		
17	Allow for the disconnection, removal, handing over to the client against an approved inventory, any existing items on site related to PSA plant installation.	Item	1		
	Total for Preliminaries and General Items Caried Forward to Summary Page				

BILLS OF QUANTITIES FOR CONTAINERISED PSA SHELTER

Item	Description				Amount (KShs)
MAIN SUMMARY PAGE					
S1	Total for Power Supply and Distribution Brought Forward				
S2	Total for Automatic Voltage Regulator Brought Forward				
S3	Total for Preliminaries and General Items				
S4	Subtotal				
S5	Allow 10% of Subtotal Above for Contingency	Item			
Total for ELECTRICAL INSTALATION WORKS					
Add 16% VAT					
Total for ELECTRICAL INSTALATION WORKS (incl VAT) Carry to Lot Summary Page					



SINGLE LINE DIAGRAMS

©NOVEMBER 2024

NOTES:

1. Coordinate with the Hospital, County Engineers and KPLC to ensure an adequately sized transformer is installed for current and medium term hospital power needs.
2. Coordinate with Hospital and County Engineers to ensure the New Distribution Panel provisions are by and large in accordance with short to medium term Electrical Infrastructure works.
3. Method of cable installation (I) is Armoured Cable buried underground in 600mm Deep trench.
4. Scope of Work Under Blue (section I) is the responsibility of the utility Kenya Power and Lighting Company KPLC. Utility to provide quote and execute any upgrade works where necessary.
5. Scope of Work Under Green (section II) encompass electrical works exclusive of Utility scope.
6. PSA Plant load to primarily comprise a 25kW motor with Star-Delta Starter.
7. Cable lengths are approximate. Exact lengths to be determined on site.

KEY PLAN

The Global Fund

OWNER

Elwak PSA plant

PROJECT

SINGLE LINE DIAGRAM

DRAWING TITLE

SCALE DATE 5/7/2024

JOB NUMBER

DRAWN

CHECKED

Current Package

E200

DRAWING NUMBER

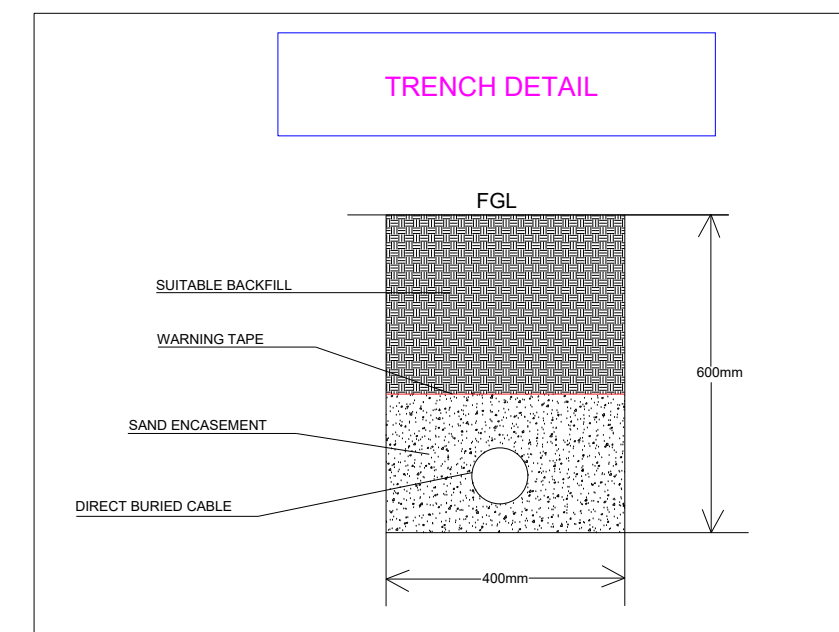

Section I

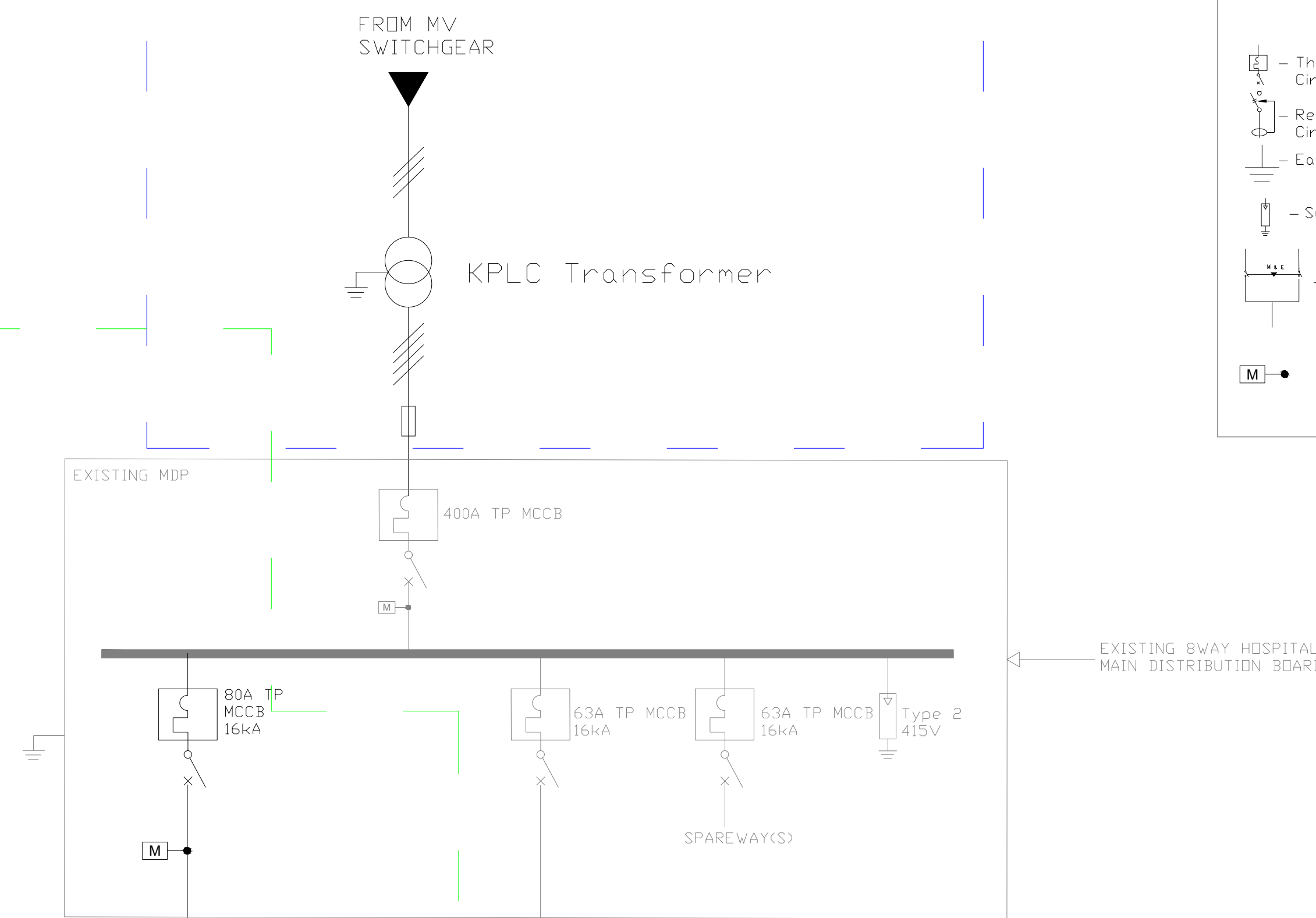

4C 35mm² + 25mm² XLPE/SWA/PVC CU Cable
130m

Section II

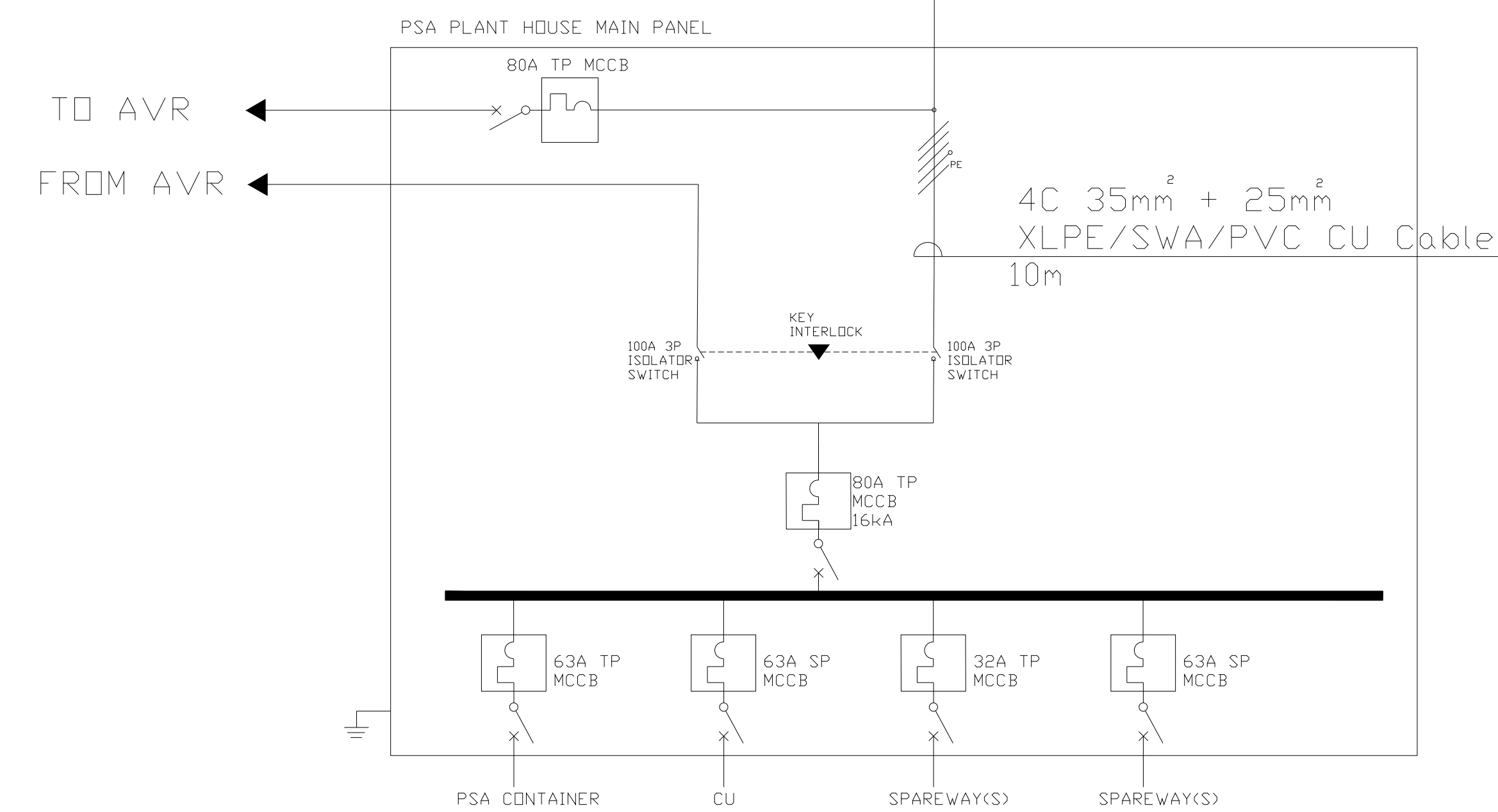

4C 35mm² + 25mm² XLPE/SWA/PVC CU Cable
10m

LEGEND:

- Thermal-Magnetic Circuit Breaker
- Residual Current Circuit Breaker
- Earth Electrode
- Surge Diverter
- Mechanically and Electrically Interlocked Automatic Transfer Switch.
- Metering
- Transformer
- Generator
- Three-Phase Line or Cable
- Three-Phase Line or Cable, with Neutral and Earth
- Single-Phase Line or Cable
- High Rupturing Capacity (HRC) Fuse
- Utility Scope
- Contractor's Scope
- Existing Scope

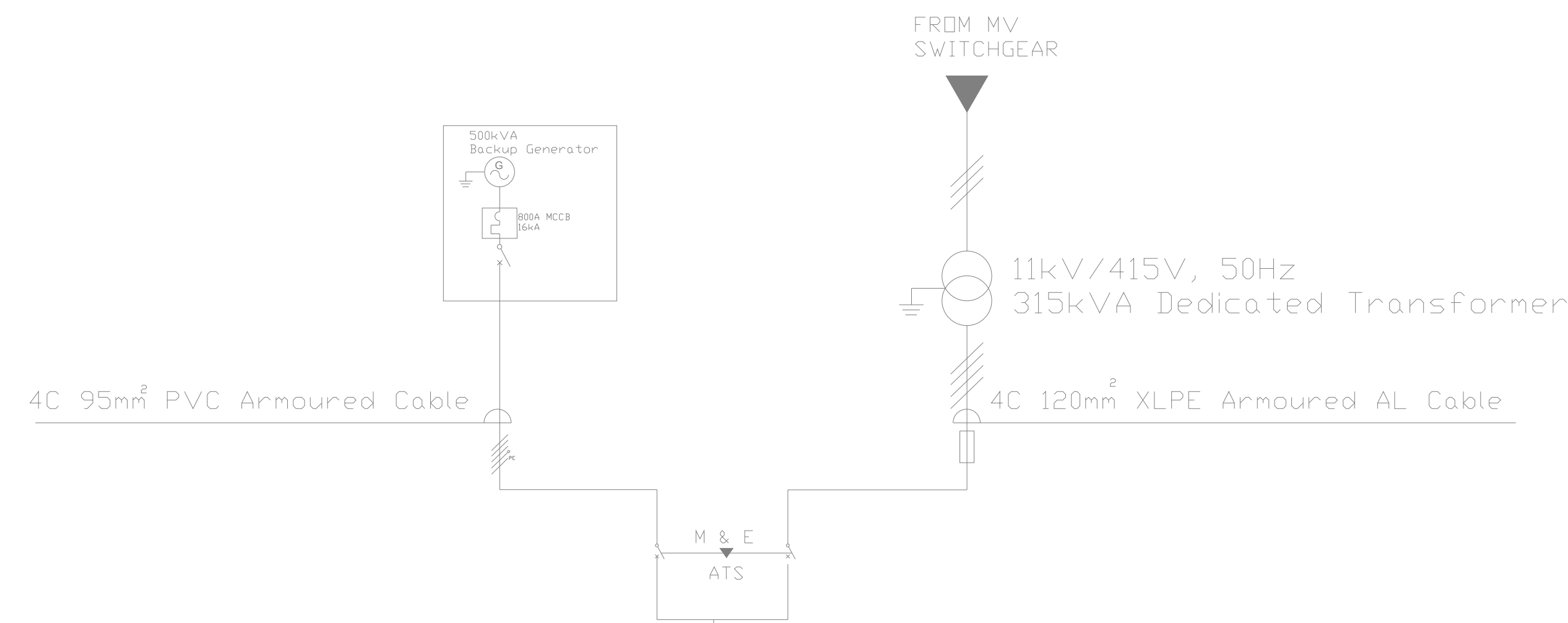
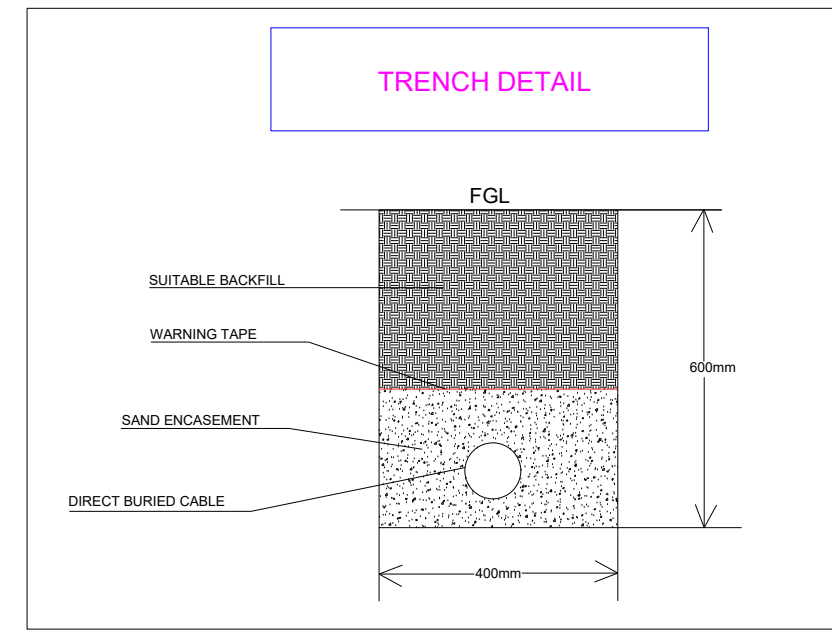

LEGEND:

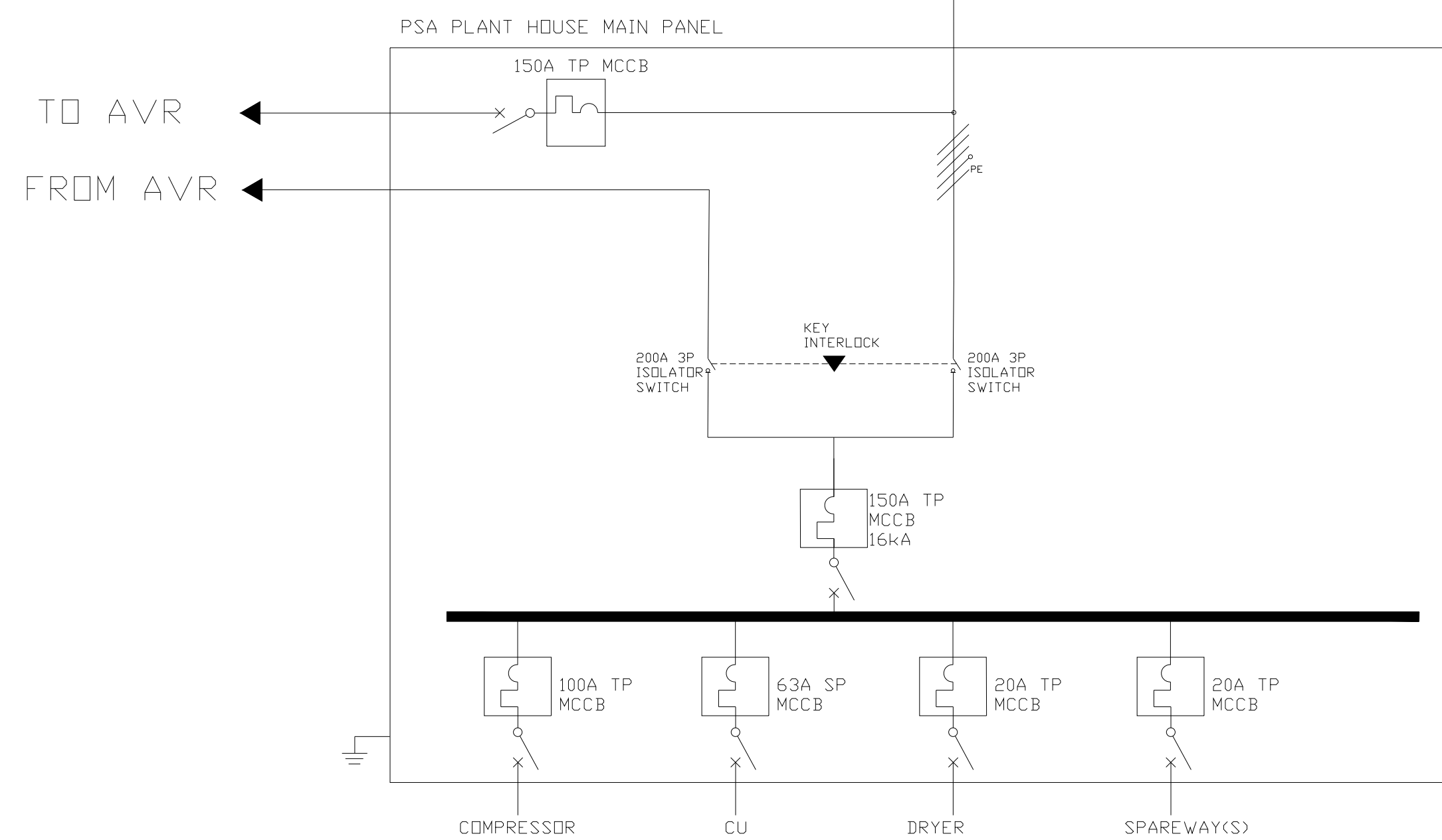
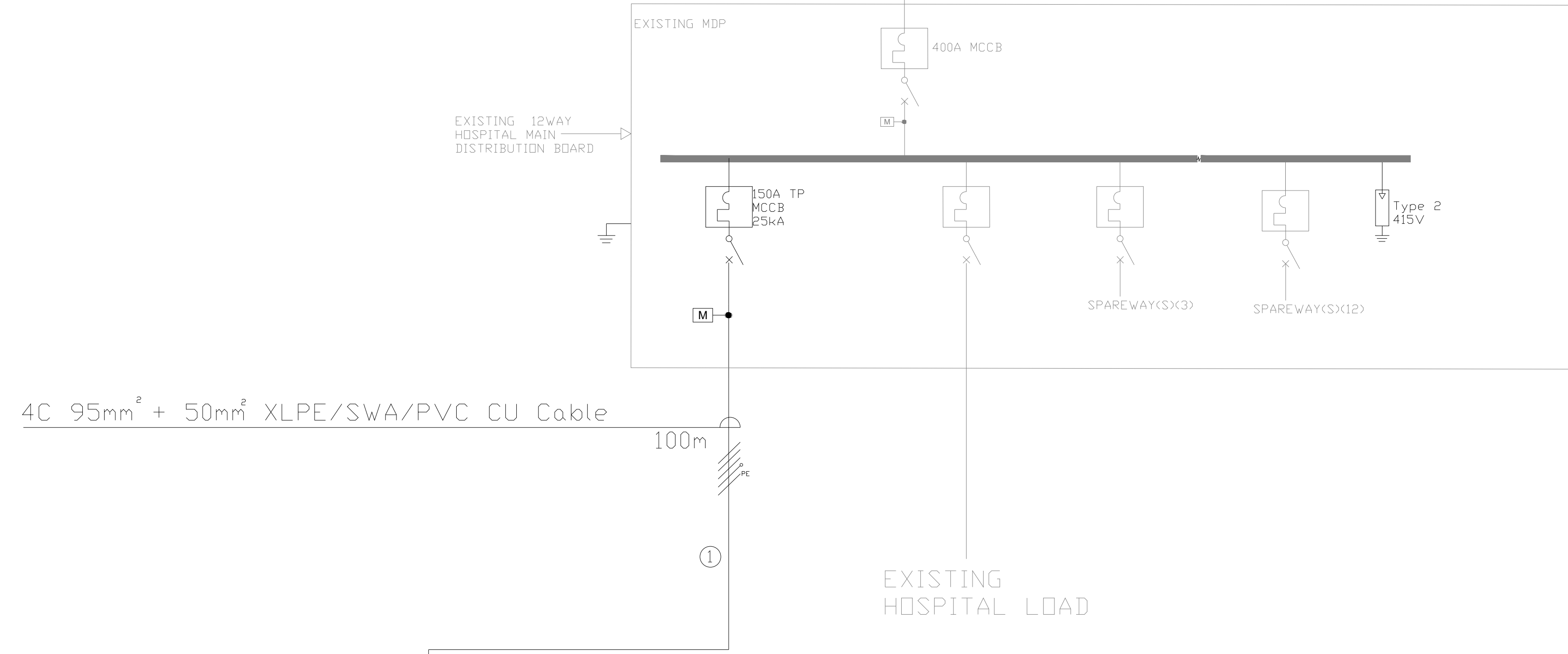
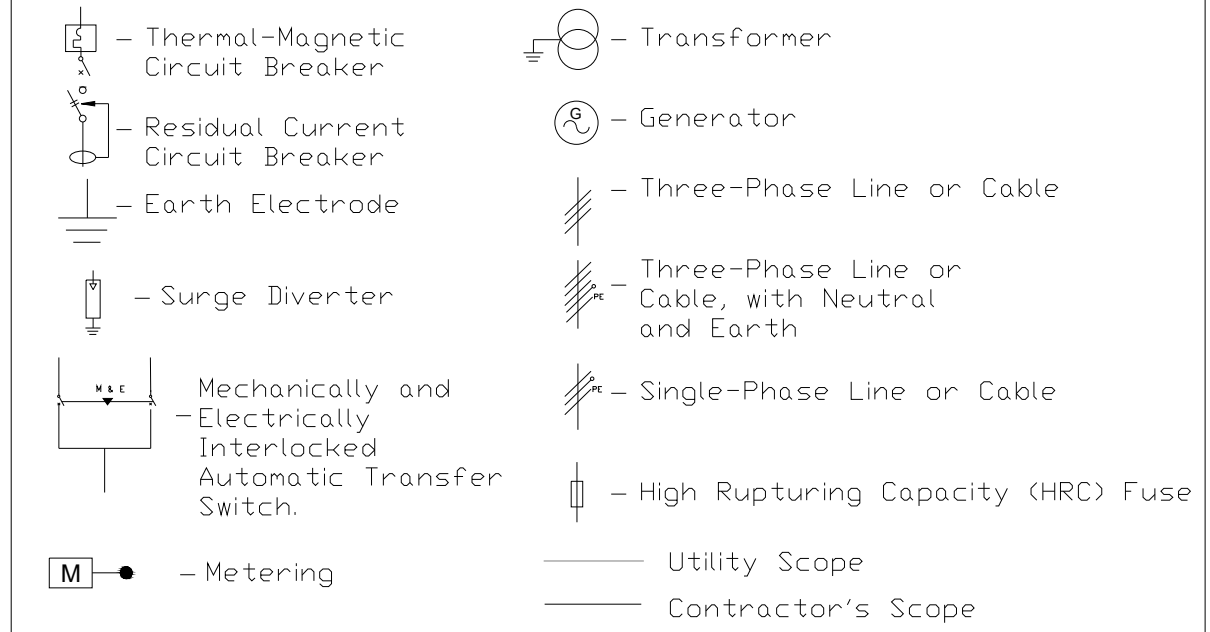

NOTES:

- Method of cable installation (1) is Armoured Cable buried underground in 600mm Deep trench.
- PSA Plant load to primarily comprise a 45kW Motor with Star-Delta Starter.
- Cable lengths are approximate. Exact lengths to be determined on site.

KEY PLAN

The Global Fund

OWNER

Mandera CRH PSA plant

PROJECT

SINGLE LINE DIAGRAM

DRAWING TITLE

SCALE

DATE 5/7/2024

JOB NUMBER

DRAWN

CHECKED

Current Package

E200

DRAWING NUMBER

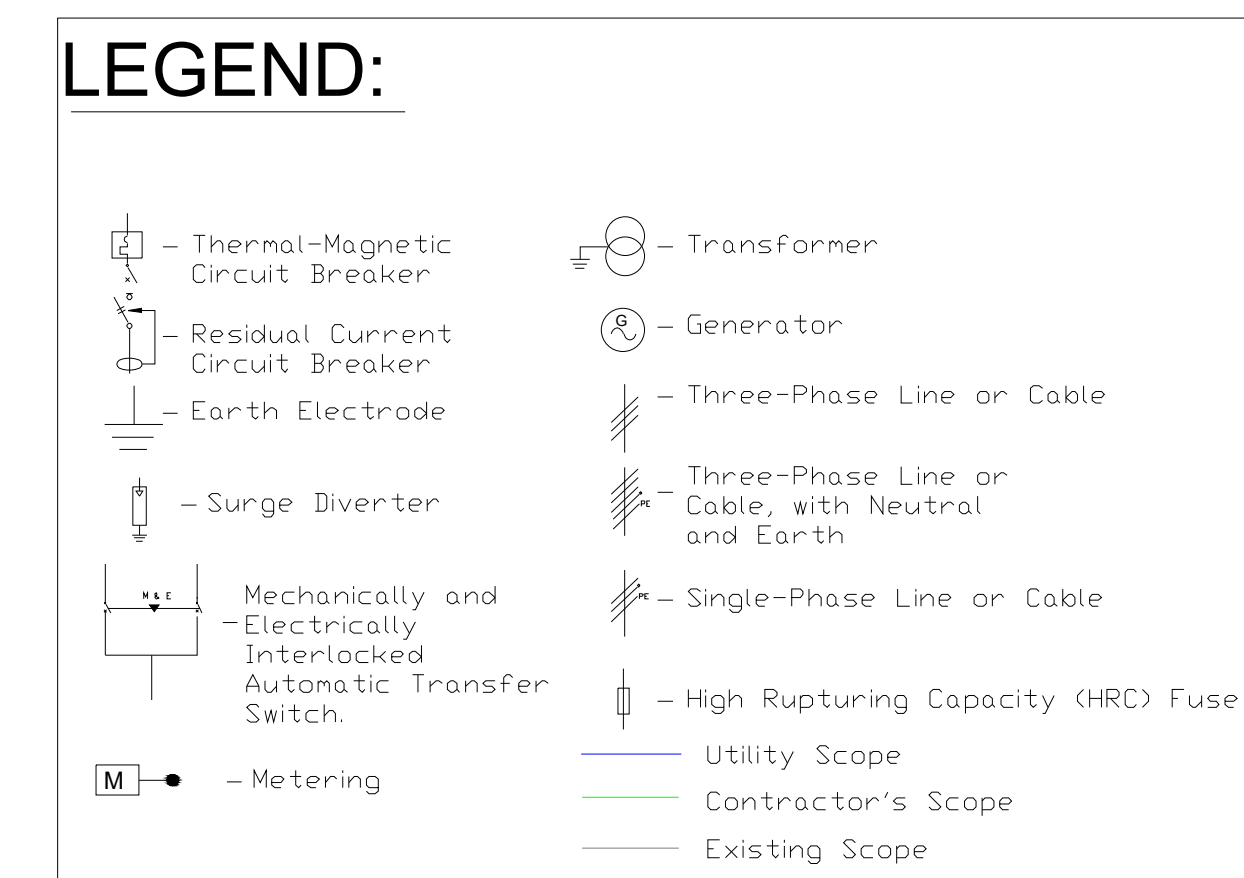
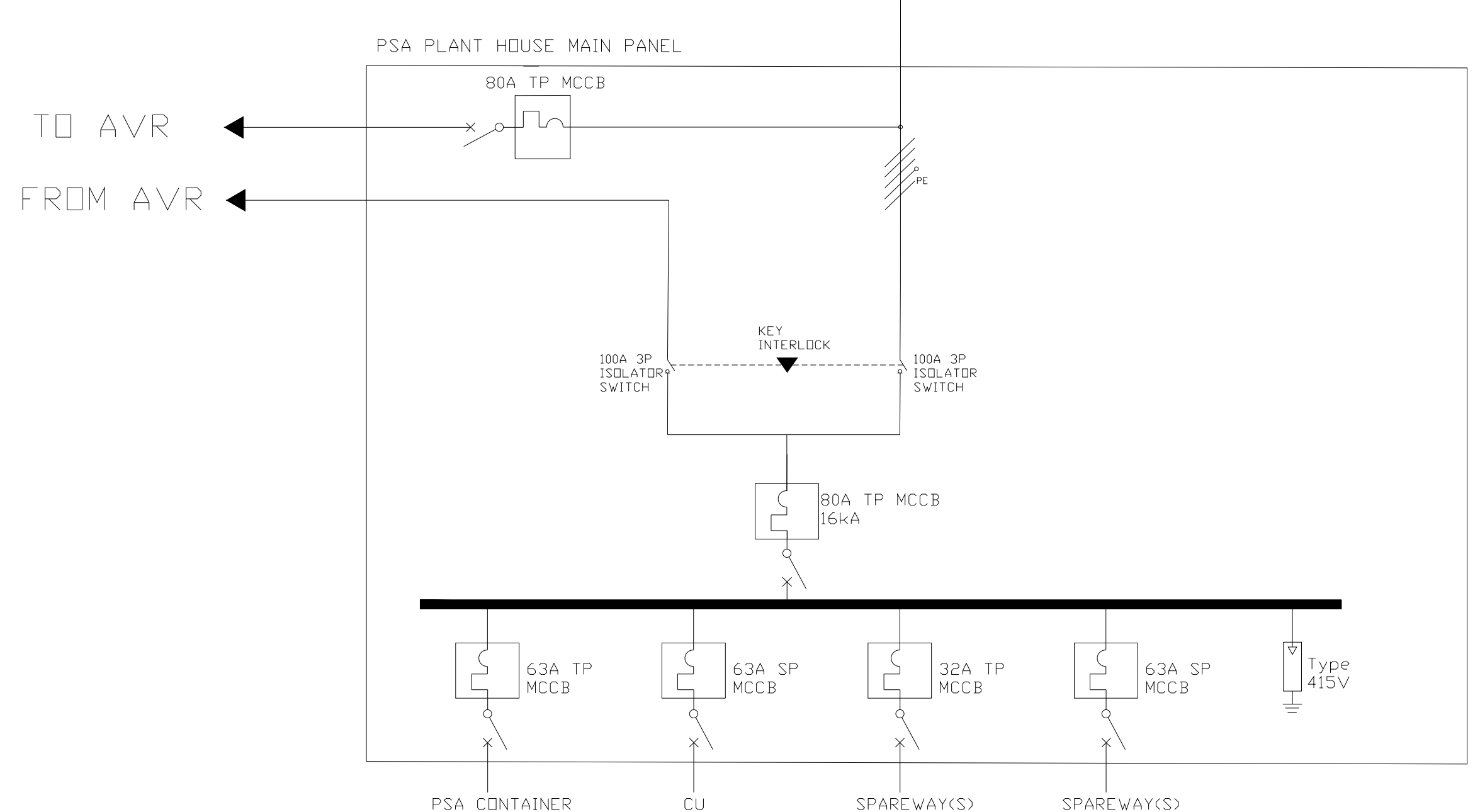
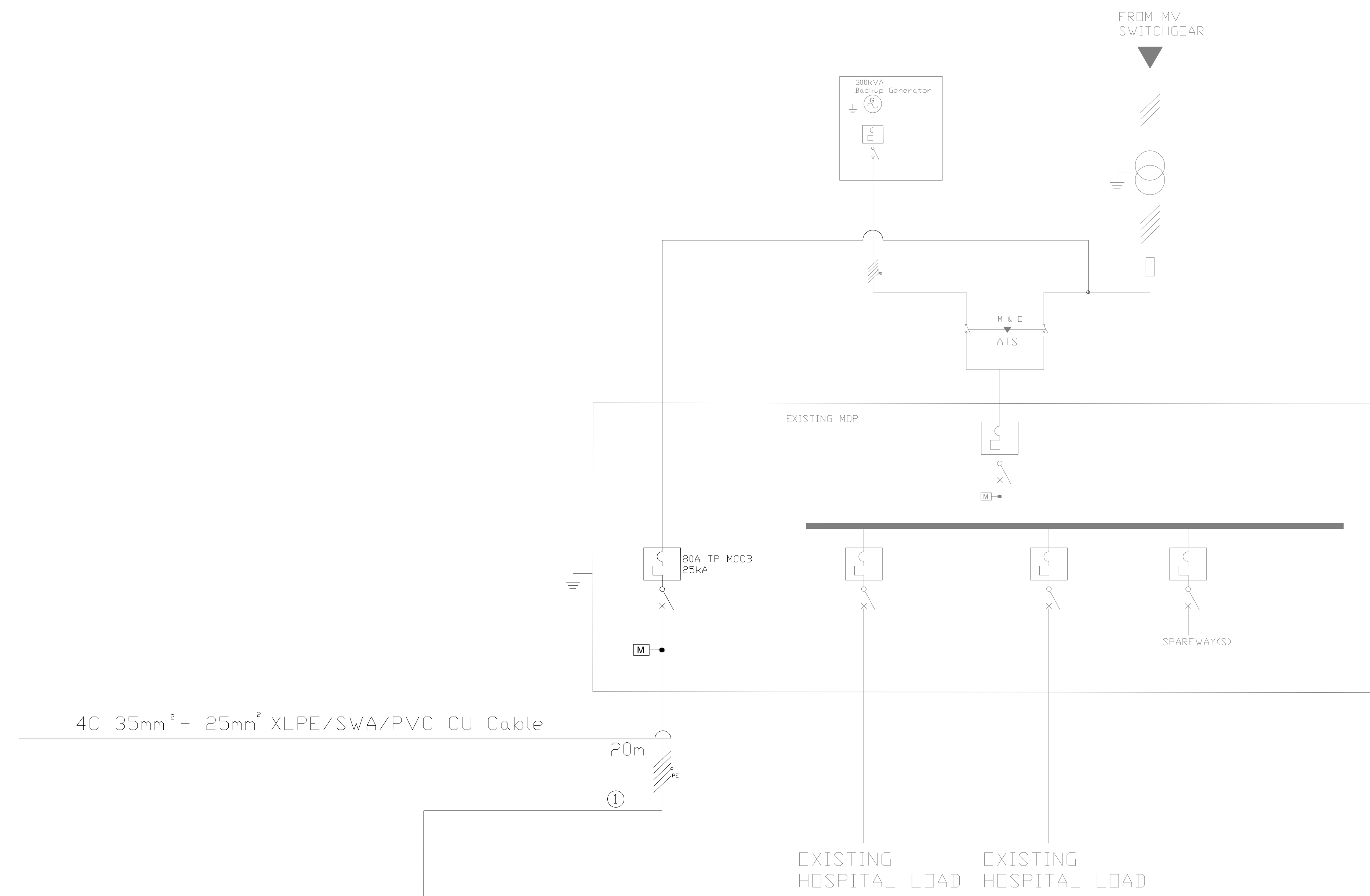
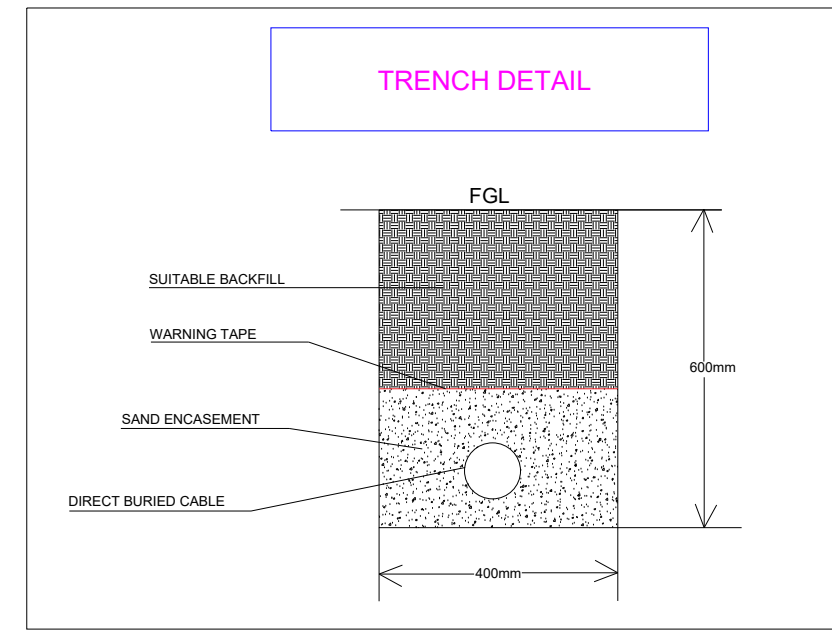

Build Health International
 100 Cummings Centre, Suite 120B
 Beverly, MA 01915
 buildhealthinternational.org



- NOTES:**
1. Coordinate with the Hospital, County Engineers and KPLC to ensure an adequately sized transformer is installed for current and medium term hospital power needs.
 2. Coordinate with Hospital and County Engineers to ensure the New Distribution Panel provisions are by and large in accordance with short to medium term Electrical Infrastructure works.
 3. Method of cable installation (I) is Armoured Cable buried underground in 600mm Deep trench.
 4. Scope of Work Under Blue (section I) is the responsibility of the utility Kenya Power and Lighting Company KPLC. Utility to provide quote and execute any upgrade works where necessary.
 5. Scope of Work Under Green (section I) encompass electrical works exclusive of Utility scope.
 6. PSA Plant load to primarily comprise a 30kW motor with Star-Delta Starter.
 7. Cable lengths are approximate. Exact lengths to be determined on site.

KEY PLAN	
The Global Fund	
OWNER	
Sololo PSA plant	
PROJECT	
SINGLE LINE DIAGRAM	
DRAWING TITLE	
SCALE	DATE 31/10/2023
JOB NUMBER	
DRAWN	CHECKED
Current Package	
E200	
DRAWING NUMBER	



OTHER SUPPORT DOCUMENTS

Site Plan Narrative Template

Elwak SCH, Kenya

Date: 7 June 2024

PSA Plant House

- GPS coordinates of the proposed plant house site: **2°48'37"N 40°56'01"E**
- The PSA plant house will go next to an existing PSA plant house.
- There are no underground utilities
- No Sources of fumes within 10m
- No trees close by or other structures that would need to be removed.
- The site is not sloped.
- There are signs of flooding near the PSA plant location.
- Concrete slab height above the exterior grade at the lowest point: 20cm

Electrical

The electrical works from the transformer/utility meter and generator all the way to the PSA plant connection will be the responsibility of the selected electrical contractor.

Generator

- The plant will be using an existing generator
- *GPS coordinates of the **existing** generator house site: **2°48'36"N 40°55'58"E**

Transformer

- An existing transformer shall be used.
- *GPS coordinates of the proposed or : **2°48'37"N 40°55'58"E**

Main Distribution Panel (MDP)

- Existing MDP shall be used
- *GPS coordinates of the existing Main Distribution Panel (MDP) for the PSA plant: **Housed with Generator**

Cables

- Cables to be buried directly in the ground

Medical Gas Piping System (MGPS)

Ward	Beds	Existing Outlets	Faulty Outlets	Outlets (New + replacement for the faulty ones)
Major OR	03			06
Minor OR	01			02
Emergency Room	08			08
MaternityRoom	60	19	06	27
Pre-Op/PACU	00			00
NICU	04			02
PICU	0			0
General ICU	6	10	08	10
HDU	06			04
General Adult Patient Ward	16			30
General Pediatric Patient Ward	30			16
TB	00			00
Total Beds	100			105

● The hospital prefers for pipes to be run as follows:

- Inside buildings: Pipes should be run along the wall in trunking
- Outside/between buildings: Mounted to existing exterior structures (i.e. existing canopy or walkway frame)
- Faulty Outlets: To be replaced by new outlets
- Existing Outlets: To be utilized

hospital the run as



LEGEND:

- PROPOSED PSA PLANT
- PROPOSED GENERATOR HOUSE
- TRANSFORMER (NOT TO SCALE)
- ELECTRICAL LINE
- PR SUGGESTED MGPS ROUTING

NO.	DATE	DESCRIPTION
-----	------	-------------

KEY PLAN

THE GLOBAL FUND

OWNER

KENYA SITE PLANS
KENYA

PROJECT

ELWAK SITE PLAN

DRAWING TITLE

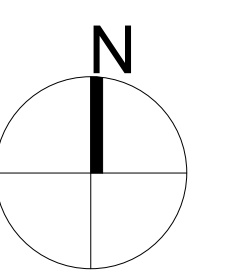

SCALE: As indicated DATE: 06/07/2024

JOB NUMBER: 62-002

DRAWN: AO CHECKED: AD

A004

DRAWING NUMBER

1 Elwak Site Plan
SCALE 1 : 750



TRANSFORMER
GENERATOR
HOUSE & MDP

150 m

EMERGENCY

PROPOSED PSA
PLANT

PEDIATRIC WARD

FEMALE WARD

MALE WARD

OPD WING

RADIOLOGY
DEPARTMENT

LEGEND:

- PROPOSED PSA PLANT
- PROPOSED GENERATOR HOUSE
- TRANSFORMER (NOT TO SCALE)
- ELECTRICAL LINE
- PR SUGGESTED MGPS ROUTING

NO.	DATE	DESCRIPTION

KEY PLAN

THE GLOBAL FUND

OWNER

KENYA SITE PLANS
KENYA

PROJECT

ELWAK SITE PLAN (GE)

DRAWING TITLE

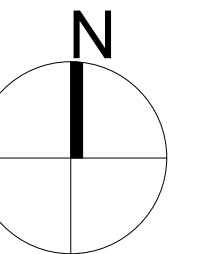

SCALE: As indicated DATE: 06/07/2024

JOB NUMBER: 62-002

DRAWN: AO CHECKED: AD

A004.1

DRAWING NUMBER

1 Elwak Site Plan - Google Earth
SCALE 1 : 750

Site Plan Narrative Template

MANDERA CRH, Kenya

Date: 4 June 2024

PSA Plant House

- GPS coordinates of the proposed plant house site: **3°56'33"N 41°51'40"E**
- There are no underground utilities
- No overhead obstructions
- There are no sources of fumes within 10m as the generator is 60m away from the PSA, incinerator and mortuary are more than 100m away.
- No overhead obstructions
- No trees close by or other structures that would need to be removed.
- The site is not sloped.
- There is evidence of flooding near the PSA plant site.
- Concrete slab height above exterior grade at the lowest point: 20cm

Electrical

The electrical works from the transformer/utility meter and generator all the way to the PSA plant connection will be the responsibility of the selected electrical contractor.

Generator

- **The PSA plant will use the existing generator.**
- *GPS coordinates of the **existing** generator house site: **3°56'33"N 41°51'39"E**

Transformer

- The PSA plant will use the existing transformer.
- *GPS coordinates of the existing Transformer: **3°56'33"N 41°51'38"**

Main Distribution Panel (MDP)

- The PSA will use existing (MDP)
- *GPS coordinates of the existing Main Distribution Panel (MDP) for the PSA plant: **3°56'33"N 41°51'39"E**

Cables

- Cables to be buried directly in the ground

Medical Gas Piping System (MGPS)

Ward	Beds	Existing outlets	Faulty outlets	Outlets (new to be added, including replacement of the faulty ones)
Major OR	03	03	00	04
Minor OR	01	00	00	02
Emergency Room	06	06	06	06
Maternity Room	60	12	09	48
Pre-Op/PACU	00	00	00	00
NICU	04	00	00	02
PICU	00	00	00	00
General ICU	06	06	06	06
HDU	09	0	0	04
General Adult Patient Ward	88	4	04	60
General Pediatric Patient Ward	21	04	02	11
TB	10	08	06	6
Total Beds	150	45	34	149

- Faulty outlets will be replaced with new outlets
- The hospital prefers for the pipes to run as follows:
 - Pipes should be run in trunking
 - Outside/between buildings: Mounted to existing exterior structures (i.e. existing canopy or walkway frame)

LEGEND:

- PROPOSED PSA PLANT
- PROPOSED GENERATOR HOUSE
- TRANSFORMER (NOT TO SCALE)
- ELECTRICAL LINE
- PR SUGGESTED MGPS ROUTING

NO.	DATE	DESCRIPTION

KEY PLAN

THE GLOBAL FUND

OWNER

KENYA SITE PLANS
KENYA

PROJECT

MANDERA SITE PLAN

DRAWING TITLE

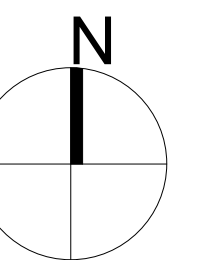

SCALE: As indicated DATE: 06/07/2024

JOB NUMBER: 62-002

DRAWN: AO CHECKED: AD

A009

DRAWING NUMBER

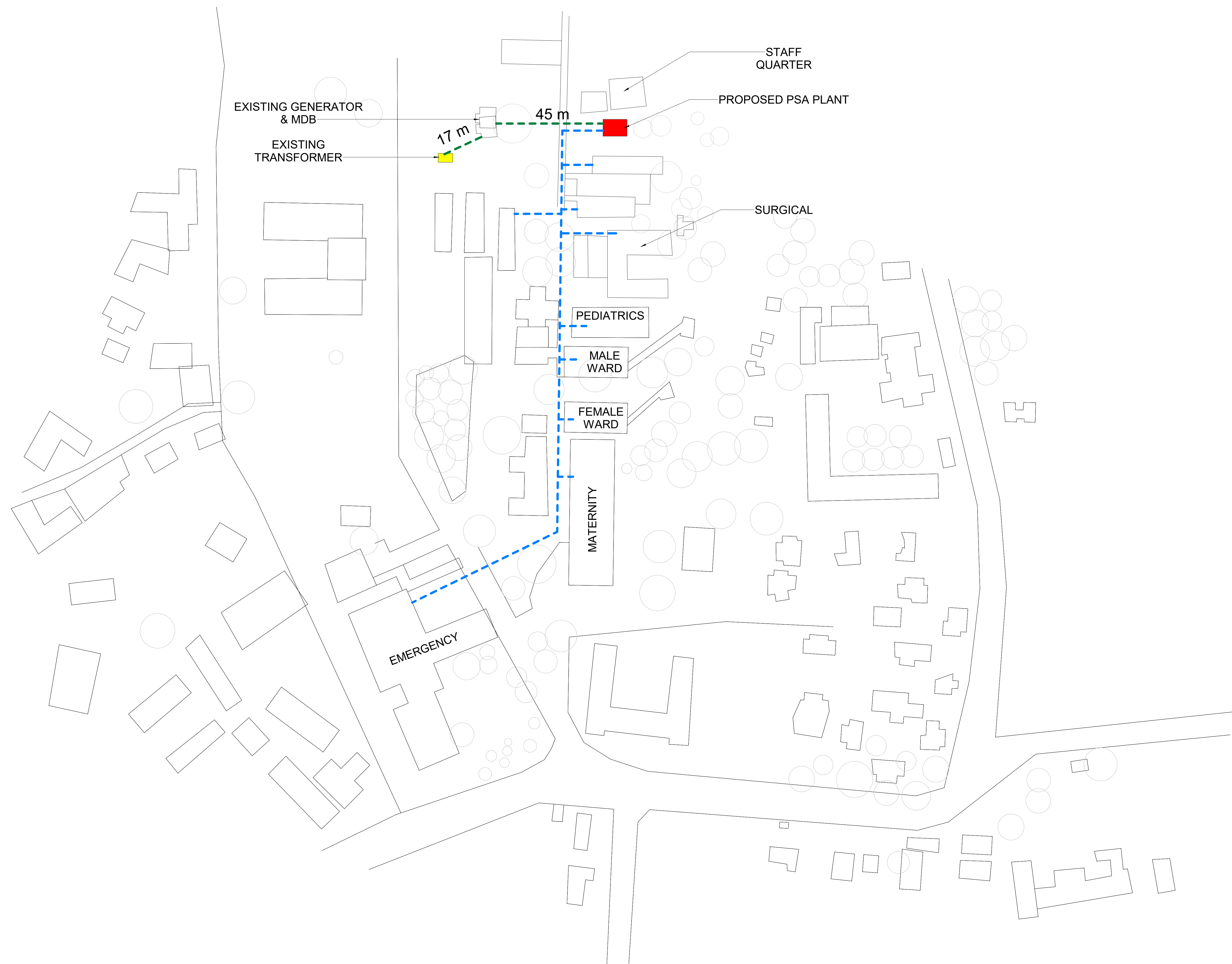

1 Mandera Site Plan
SCALE 1 : 750

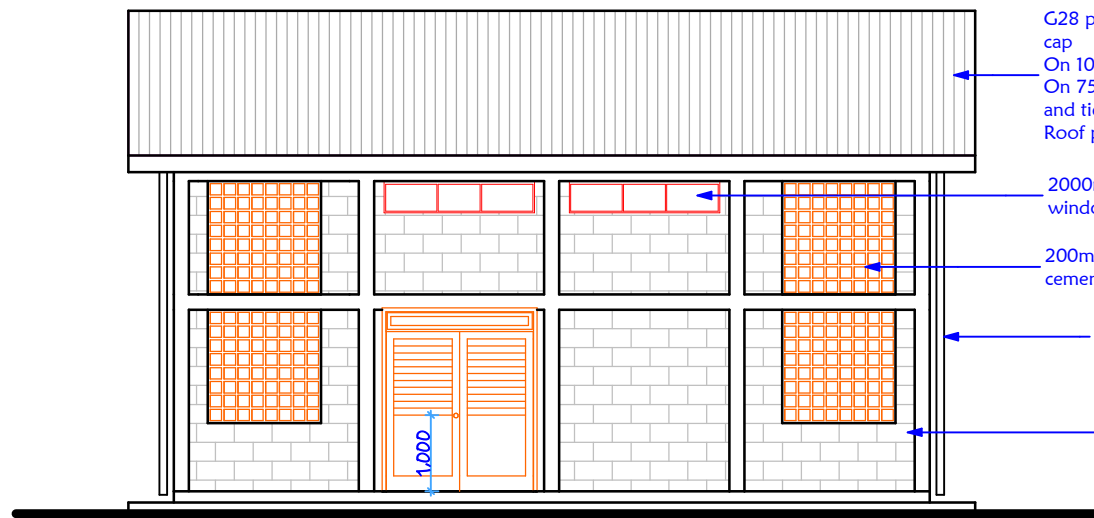

ENTRANCE ELEVATION 01

G28 prepainted box profile roofing sheet with a matching ridge cap
 On 100x50x2mm Zed purlins
 On 75x50 x3mm rafters braced with 50x50x3mm SHS struts and ties
 Roof pitched at 25° (degrees).

2000mm wide x 400mm high fixed window for natural lighting

200mm louvre block walling in cement sand mortar

80mm dia down pipe

Horizontal keyed walls

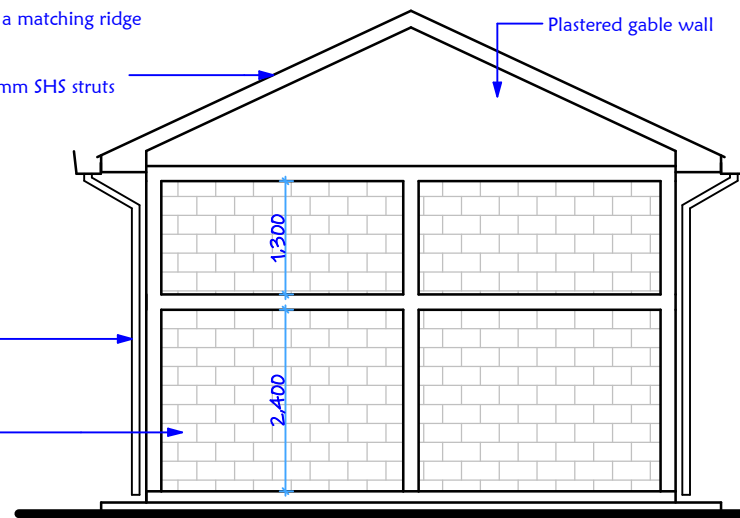

ELEVATION 02

Plastered gable wall

1300

2400

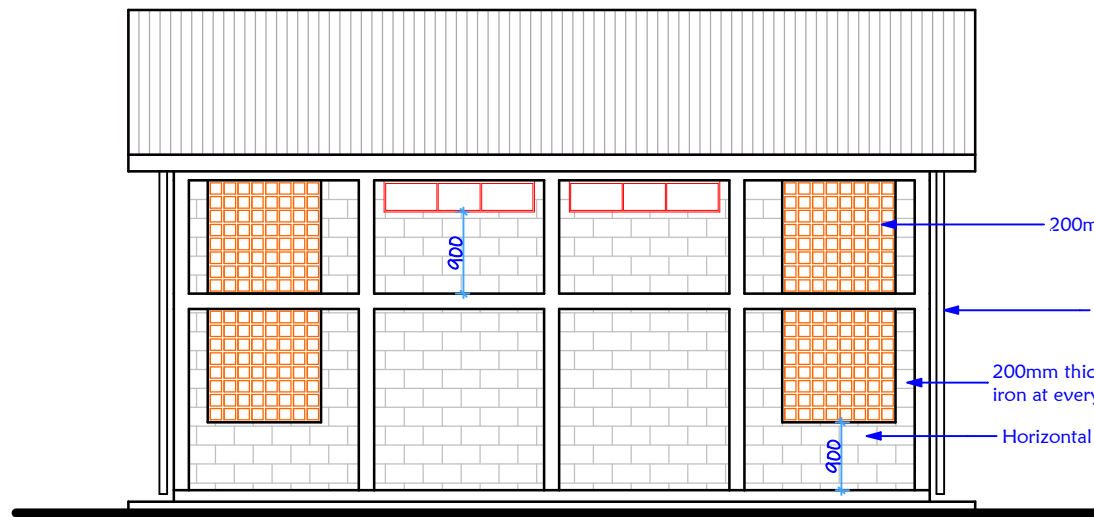

ELEVATION 03

200mm louvre block walling in cement sand mortar

80mm dia down pipe

200mm thick masonry walling reinforced with hoop iron at every alternate courses

Horizontal keyed/plastered walls

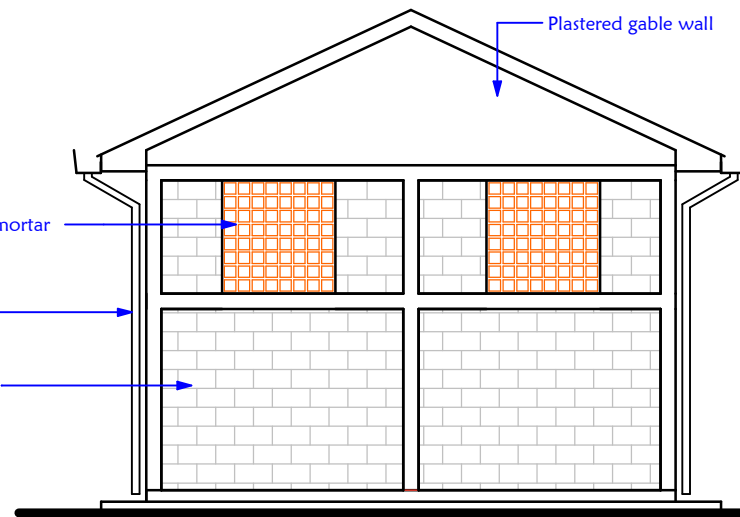

ELEVATION 04

Plastered gable wall

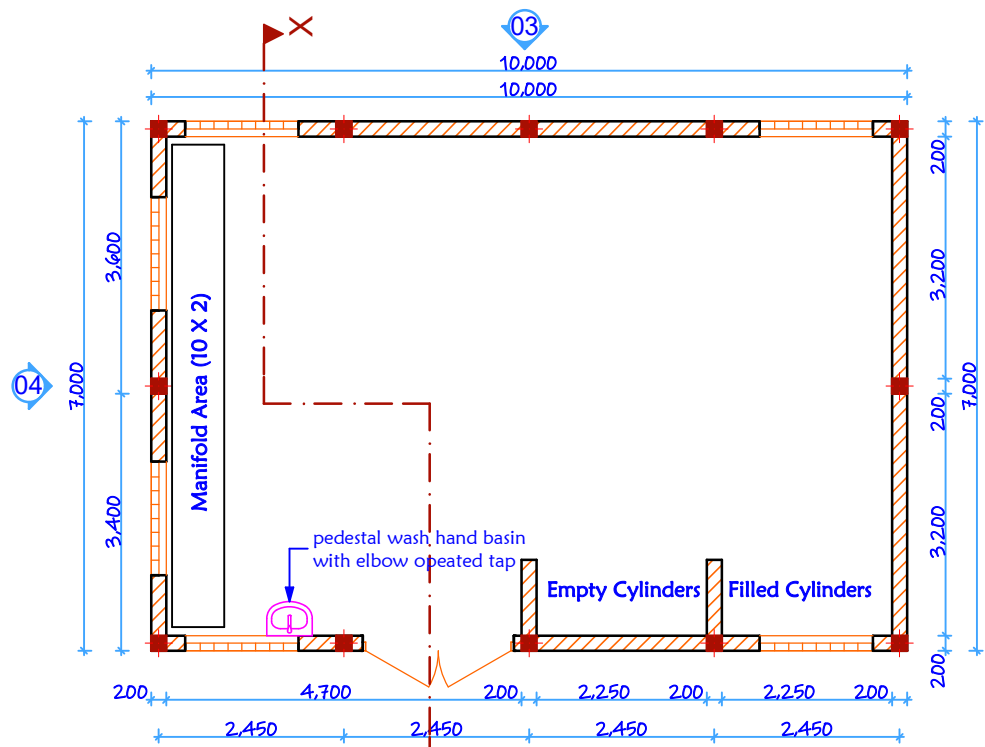

FLOOR PLAN

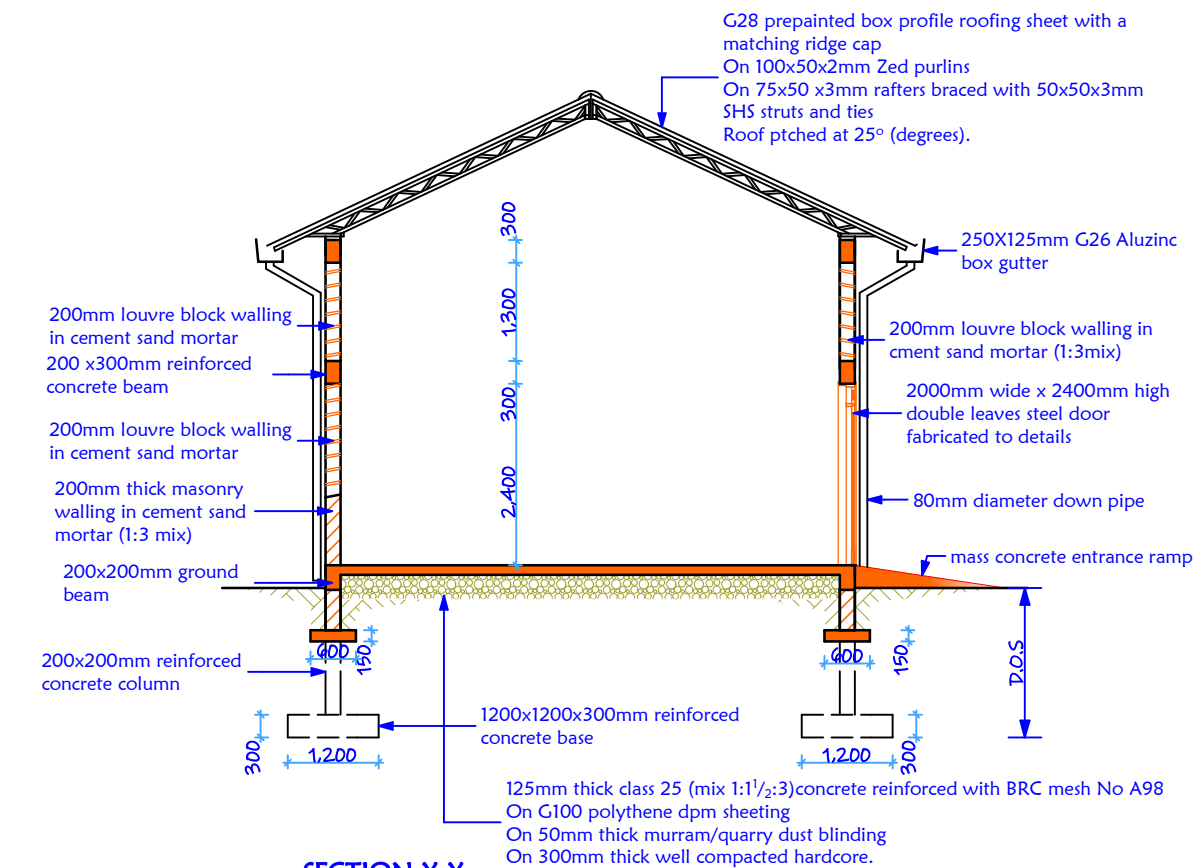

SECTION X-X

G28 prepainted box profile roofing sheet with a matching ridge cap
 On 100x50x2mm Zed purlins
 On 75x50 x3mm rafters braced with 50x50x3mm SHS struts and ties
 Roof pitched at 25° (degrees).

250x125mm G26 Aluzinc box gutter

200mm louvre block walling in cement sand mortar (1:3mix)
 2000mm wide x 2400mm high double leaves steel door fabricated to details

80mm diameter down pipe

mass concrete entrance ramp

200mm louvre block walling in cement sand mortar
 200 x300mm reinforced concrete beam

200mm louvre block walling in cement sand mortar

200mm thick masonry walling in cement sand mortar (1:3 mix)

200x200mm ground beam

200x200mm reinforced concrete column

1200x1200x300mm reinforced concrete base

125mm thick class 25 (mix 1:1½:3) concrete reinforced with BRC mesh No A98
 On G100 polythene dpm sheeting
 On 50mm thick murrum/quarry dust blinding
 On 300mm thick well compacted hardcore.

GENERAL NOTES

1. All dimension are in metric mm unless specified.
2. Dimensions to be read NOT scaled, only figured dimensions to be used.
3. Contractor to check and verify all dimensions on site before commencement of any works.
4. Any discrepancies to be reported to the project architect.
5. All works to be strictly in accordance with standard specifications and notes.
6. This drawing is to be read in conjunction with specification and all other relevant drawings.
7. Walls to be reinforced with hoop iron at every alternate courses.
8. Depth of the foundation to be determined on site.
9. PV denotes permanet air vents above doors and windows as shown on the drawing.
10. Drainage pipes passing under building to be encased in 150mm thick concrete surround.
11. All reinforced concrete works to Structural Engineers details.
12. All inspection chamber covers and framing shall be in compliance to approved standards.
13. All testing of pipes MUST be done before plastering.
14. All black cotton soil to be removed from below and around the building.
15. All soils under the building and around the external foundation to be treated with approved anti-termites treatment.

REVISION NOTES		
DATE	DESCRIPTION	REV BY

project: **PROPOSED ONSITE PSA SHELTER - REVISED**

location: **Text**

organization:  **amref health africa**

P. O. Box 30125 - 00100 NAIROBI.

drg title: **PLANS, ELEVATIONS & SECTION**

stage: **WORKING DRAWING** date: **APRIL, 2024**

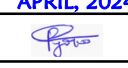
designed & drawn by: **P. O** signed: 

scale: **1 : 100 mm**

Site Plan Narrative

Sololo Level 4 Hospital, Kenya

Date: 4 June 2024

PSA Plant House

- The PSA plant site is next to the generator house, which is approximately 18 meters from the main building.
- No underground utilities beneath the site that will need to be moved or worked around.
- No overhead obstructions (e.g., power cables) that will impede delivery or installation of the PSA plant.
- There are no sources of fumes within 10m of the PSA plant site that could need to be accounted for when installing the plant.
- There are no trees, buildings, or other obstacles that will need to be removed in order to construct the PSA plant house .
- GPS Coordinates: <https://maps.app.goo.gl/BfDV2ZkzdvD5ikTa7>
- The area of the PSA plant is raised so it doesn't experience flooding. The site is also sloped. The concrete slab should be raised 20cm above exterior grade at the lowest point.

Electrical

The electrical works from the transformer/utility meter and generator all the way to the PSA plant connection will be the responsibility of the selected electrical contractor.

Generator

- The facility has two generators supporting the existing hospital loads. One is the major standby and one is the minor standby generator. The existing generators have enough load to support the incoming PSA plant.
- GPS coordinates: <https://maps.app.goo.gl/jETX49QFY1UJ2Nua9>

Transformer

- The facility has 315kva transformer dedicated to the hospital. The transformer has enough capacity to support the addition of the PSA plant.
- Existing transformer location: <https://maps.app.goo.gl/KZw5m4LZ86VzZ5W56>

Main Distribution Panel (MDP)

- The PSA plant MDP will be a new MDP and it will be installed in the PSA plant
- <https://maps.app.goo.gl/KZw5m4LZ86VzZ5W56>

Cables

- The cables should run underground within a duct.

Medical Gas Piping System (MGPS)

Ward	Bed- yet to be assembled.	Outlets Counted to be installed
Major OR	0	2
Minor OR	0	1
Emergency Room	0	5
NICU	0	7
General wards(male and female ward)	0	8
Renal unit/ICU	0	6
General Pediatric Patient Ward	0	6
TB	0	2
Total	150 beds	37 outlets

- The piping plans can be engineered and proposed by the contractor.
 - Inside buildings:
 - Will the pipes run along the walls ,On the ceiling, Pipe along wall, Pipe along the ceiling as per the best way to navigate the piping works.
 - Outside/between buildings:
 - Accessible underground trenching with use of PPR as the conduit to allow covering of the oxygen piping -protecting vandalizing the piping works,the access points should have a draining point.(small deliberate hole at the corner areas.
 - Mounted to existing exterior structures (i.e. existing canopy or walkway frame)as per need .

SOLID LEVEL FOUR MAPPING. Tx 315kVA

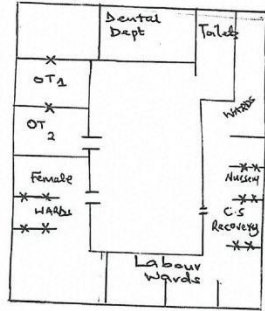
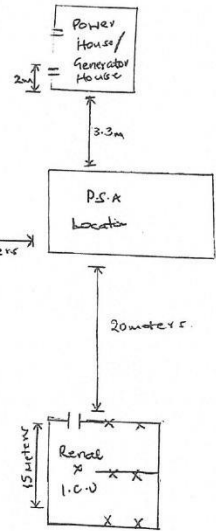

FIRST FLOOR

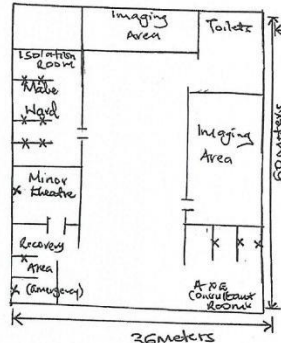

GROUND FLOOR

KEY
 X - oxygen outlet
 T - Door outlet
 K - Distance.



4/03/24.

CHIEF EXECUTIVE OFFICER
 MOYALE SIR COUNTY REFERRAL HOSPITAL
 P. O. Box 57 - 60700,
 MOYALE



This is a site area not able to establish the location -

- The hospital is growing but the location selected for both psa and generator will not be affected by the overhead buildings or other underground lines, flooding.

PROPOSED PSA
PLANT & MDP

EXISTING
GENERATOR
HOUSE

TRANSFORMER

MATERNITY

10 m

25 m

1 Sololo Site Plan

SCALE 1 : 500

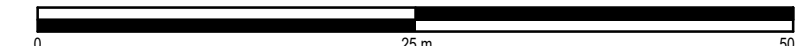

100 Cummings Center, Suite 120B
Beverly, MA 01915
Phone: (978) 969-0920
buildhealthinternational.org



Global health Campus
Chemin du Pommier 40
1218 Grand-Saconnex
Geneva, Switzerland
Phone: +41 58 791 1700
Fax: +41 22 544 1283

LEGEND:

- PROPOSED PSA PLANT
- PROPOSED GENERATOR HOUSE
- TRANSFORMER (NOT TO SCALE)
- ELECTRICAL LINE
- PR SUGGESTED MGPS ROUTING

NO.	DATE	DESCRIPTION

KEY PLAN

THE GLOBAL FUND

OWNER

KENYA SITE PLANS
KENYA

PROJECT

SOLOLO SITE PLAN

DRAWING TITLE

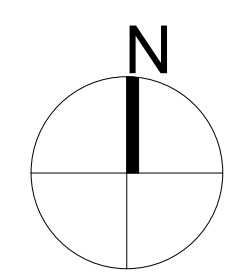

SCALE As indicated DATE 06/03/2024

JOB NUMBER 62-002

DRAWN AO CHECKED AD

A021

DRAWING NUMBER

6/3/2024 1:45:29 PM
Ariseba Dinesh/02-002 The Global Fund Co consulting/02-002_C01 Consulting_Matery_Site Plans_A_2024.rvt
KENYA SITE PLANS

PROPOSED PSA
PLANT & MDP

EXISTING
GENERATOR
HOUSE

TRANSFORMER

MATERNITY



1 Sololo Site Plan - Google Earth
SCALE 1 : 500

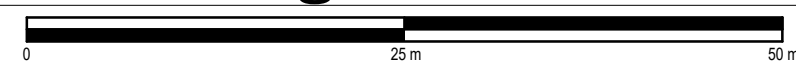

LEGEND:

- PROPOSED PSA PLANT
- PROPOSED GENERATOR HOUSE
- TRANSFORMER (NOT TO SCALE)
- ELECTRICAL LINE
- PR SUGGESTED MGPS ROUTING

NO.	DATE	DESCRIPTION
-----	------	-------------

KEY PLAN

THE GLOBAL FUND

OWNER

KENYA SITE PLANS
KENYA

PROJECT

SOLOLO SITE PLAN (GE)

DRAWING TITLE

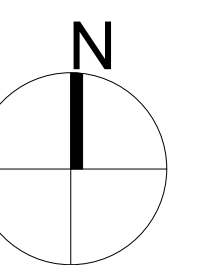

SCALE	As indicated	DATE	06/03/2024
JOB NUMBER	62-002		
DRAWN	AO	CHECKED	AD

A021.1

DRAWING NUMBER

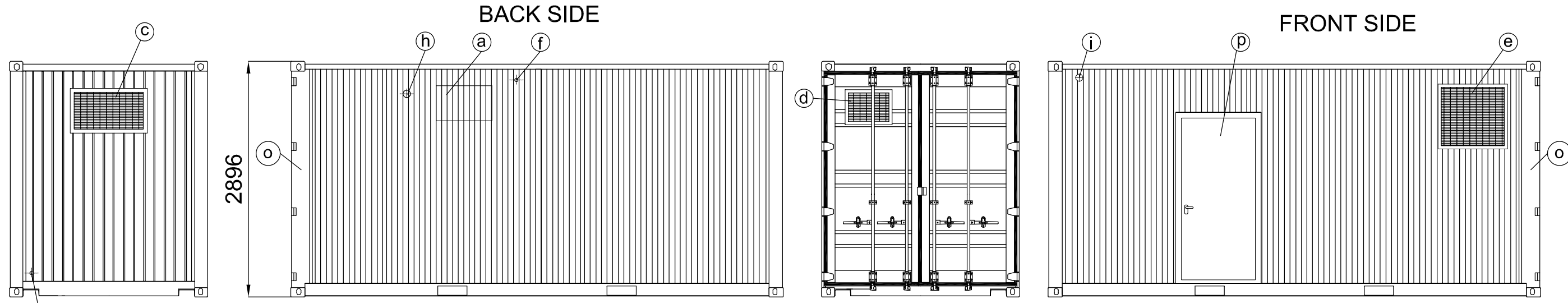

- (a) air conditioner 2.7 kw
- (b) plant equipment distribution board
- (c) ventilation grid
- (d) ventilation grid
- (e) expulsion grid
- (f) hole for oxygen pipe outlet to pipeline
- (g) drain
- (h) power supply 400V 3P + N + GND inlet point provision
- (i) N2 exhaust grid
- (l) light switch
- (m) light and conditioner distribution board
- (n) auxiliary electrical socket
- (o) inlet door
- (p) service door
- (q) additional light switch

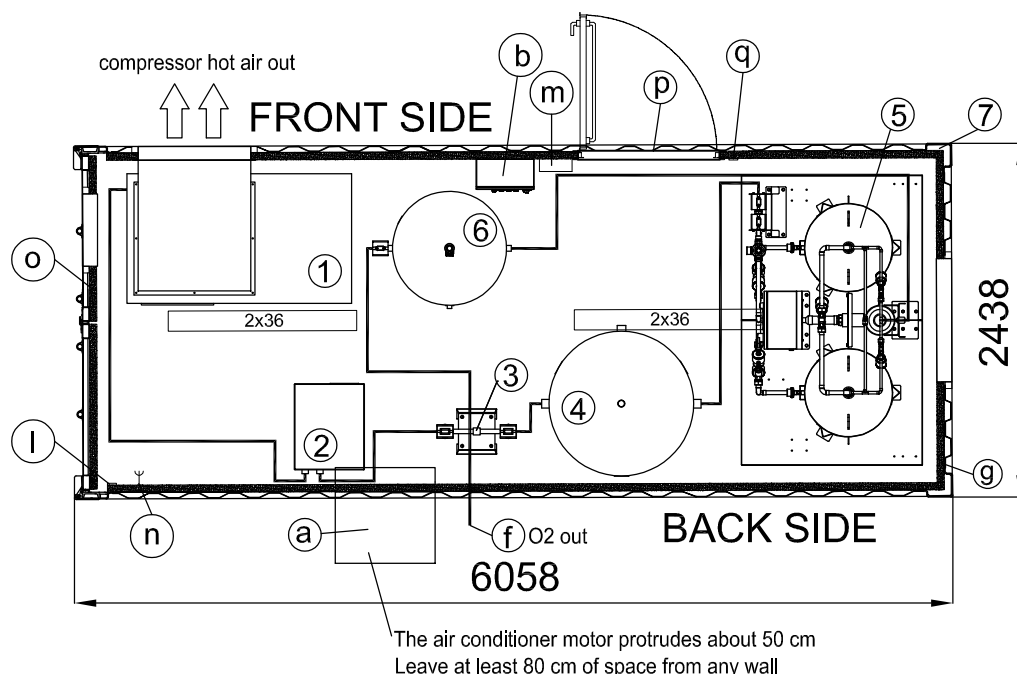

① COMPRESSOR	
MANUFACTURER	GARDNER & DENVER (CHAMPION)
MODEL	FM 30@10 bar
SUPPLY VOLTAGE	400 Volt / 50 Hz / 3PH
ENGINE POWER	30 kW
MAX POWER AT FULL LOAD	36 kW
FULL LOAD CURRENT MAX (400 V)	64 A
ROOM TEMPERATURE MAX/MIN	° C MÁX. +40 / MIN. +10
dB(A)	71
DIMENSIONS (LXPXH)	1554mm x 894mm x 1405mm
WEIGHT	700 Kg

⑤ OXYGEN GENERATOR 13,9 Nm3/h	
SUPPLY VOLTAGE	230 Volt / 50-60 Hz / 1+N ~ 500 W
DIMENSIONS (LXPXH)	2000 mm x 1250 mm x 2071mm
ROOM TEMPERATURE MAX/MIN	° C MÁX. +40 / MIN. +10
WEIGHT	1800 Kg

⑥ OXYGEN TANK 11,5 BAR	
CAPACITY	1000 L
DIMENSIONS (ØXH)	790mm x 2345mm
WEIGHT	204 Kg
ROOM TEMPERATURE MAX/MIN	° C MÁX. +40 / MIN. +10

② AIR DRYER	
MANUFACTURER	OMI SRL (GARDNER & DENVER GROUP)
MODEL	ED360
SUPPLY VOLTAGE	230 Volt / 50 Hz / 1PH
POWER	0,9 kW
ROOM TEMPERATURE MAX/MIN	° C MÁX. +40 / MIN. +10
DIMENSIONS (LXPXH)	500mm x 680mm x 980mm
WEIGHT	79 Kg

- ⑦ CONTAINER 20' HQ equipped with:
1. air conditioner monoblock type
 2. electrical system + lights
 3. cohibentation
 4. iron floor
 5. duct for compressor expulsion
 6. ventilation grid
 7. equipment distribution board composed by
 - Main breaker: 400V/50Hz 3P + N +GND
 - Branch breaker (Air compressor) : 36kW 400V/50Hz 3PH
 - Branch breaker (Refrigerant air dryer) : 0,6 kw 230V/50Hz 1PH
 - Branch breaker (Oxygen concentrator) : 0,5kw 230V/50Hz 1PH
 - Branch breaker (Drain) : 30 W 230V/50Hz 1P
 - Branch breaker (Auxiliary) : 3kW
 - Total power 41 kw
 8. Container total weight about 7500 kg
- IT WILL BE THE CUSTOMER'S RESPONSIBILITY TO CONNECT THE MAIN POWER SUPPLY FROM THE CABIN OF THE HEALTH CARE FACILITY TO THE PLANT EQUIPMENT DISTRIBUTION BOARD (ITEM b)

③ ACTIVATED CARBON TOWER - EVOcas 22	
FLOW (Nm3/h)	216 Nm3/h
WORKING PRESSURE (bar)	10 bar
ROOM TEMPERATURE MAX/MIN	° C MÁX. +40 / MIN. +10
DIMENSIONS	665x313x1620 mm

④ AIR TANK 11,5 BAR	
CAPACITY	1500 L
DIMENSIONS (ØXH)	1000mm x 2305mm
WEIGHT	278 Kg
ROOM TEMPERATURE MAX/MIN	° C MÁX. +40 / MIN. +10

NOTE: graphic of each container to be defined. A proposal by Delta P will follow for customer approval

Description: **CONTAINER 20"HQ N°1 LINE 13.9MC/h** **CODE: O2D0057-3002**

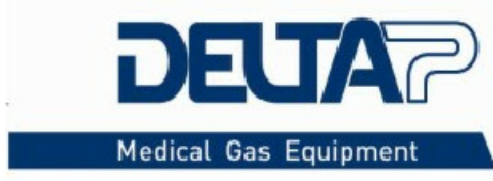

DELTA P S.r.l. Via Thansau, 4
20088 Rosate (MI) Italy
Tel. +39 02.900.05.313
Fax +39 0200.05.255
info@deltap.it - www.deltap.it



REF PERSON: **Mr Luca Volpones - Export Manager**
luca.volpones@deltap.it - export@deltap.it
Mob: +39 348 5322863 - Skype: deltapexport

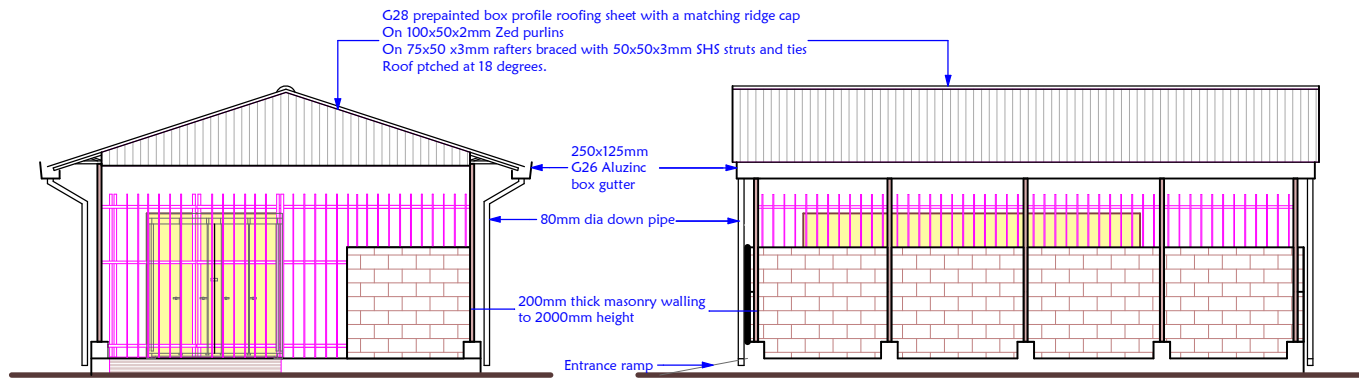

ENTRANCE ELEVATION 01

ELEVATION 02

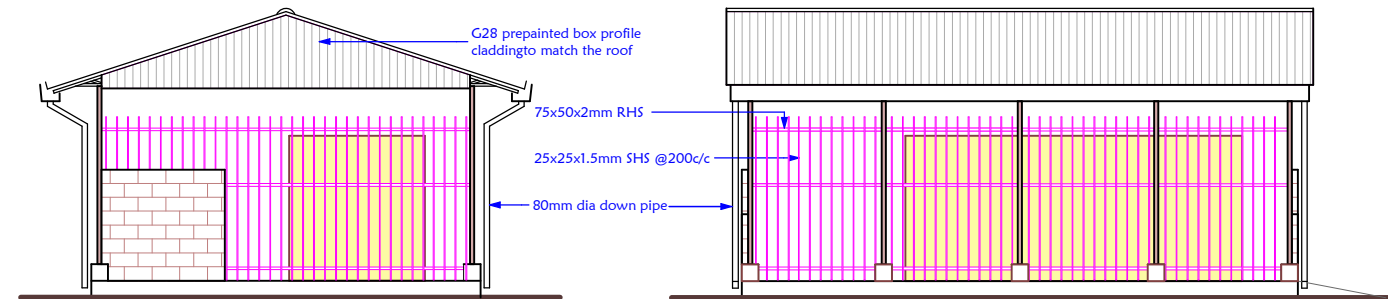

ELEVATION 03

ELEVATION 04

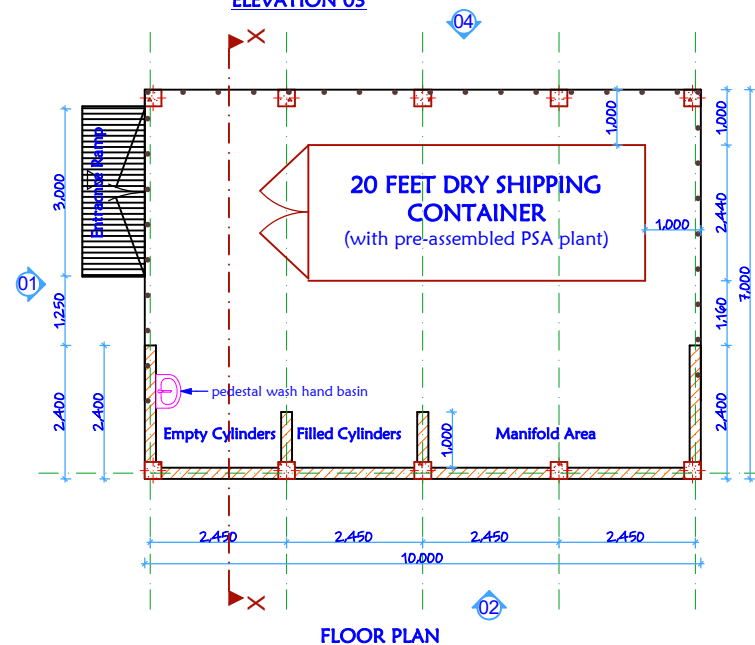

FLOOR PLAN

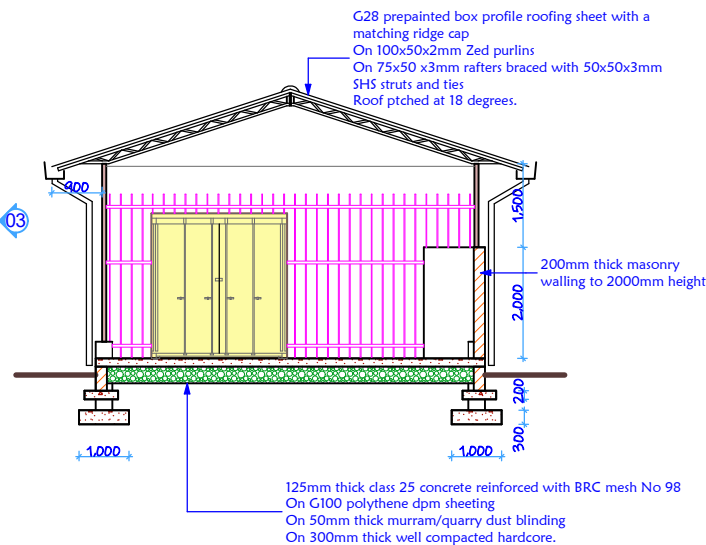

SECTION X-X

GENERAL NOTES

1. All dimension are in metric mm unless specified.
2. Dimensions to be read NOT scaled, only figured dimensions to be used.
3. Contractor to check and verify all dimensions on site before commencement of any works.
4. Any discrepancies to be reported to the project architect.
5. All works to be strictly in accordance with standard specifications and notes.
6. This drawing is to be read in conjunction with specification and all other relevant drawings.
7. Walls to be reinforced with hoop iron at every alternate courses.
8. Depth of the foundation to be determined on site.
9. PV denotes permanent air vents above doors and windows as shown on the drawing.
10. Drainage pipes passing under building to be encased in 150mm thick concrete surround.
11. All reinforced concrete works to Structural Engineers details.
12. All inspection chamber covers and framing shall be in compliance to approved standards.
13. All testing of pipes MUST be done before plastering.
14. All black cotton soil to be removed from below and around the building.
15. All soils under the building and around the external foundation to be treated with approved anti-termites treatment.

REVISION NOTES		
DATE	DESCRIPTION	REV BY

project: **PROPOSED CONTAINERISED PSA SHELTER (20 FEET CONTAINER)**

location: **RUMURUTI DISTRICT HOSPITAL, LAIKIPIA COUNTY.**

organization: **amref health africa**
P. O. Box 30125 - 00100 NAIROBI.

dwg title: PLANS, ELEVATIONS & SECTION	
stage: WORKING DRAWING	date: MARCH, 2024
designed & drawn by: P. O	signed: <i>[Signature]</i>
scale: 1 : 100 mm	