



TENDER DOCUMENT

**SUPPLY, DELIVERY, INSTALLATION, TESTING,
TRAINING AND COMMISSIONING OF STANDBY
GENERATOR SETS AND RELATED WORKS**

AMREF HEALTH AFRICA IN KENYA

TENDER NO: AMREF/26/02/2025/006

LOT NUMBER TWO (2)

INTRODUCTION

Amref Health Africa hereinafter referred to as the Client, Employer or Project Manager intends to invite eligible bidders to tender for the supply, delivery, installation, testing, training and commissioning of Standby Generator Sets and related works in various health facilities.

Proposed works will comprise the following;

- (a) Diesel Generator Set supply and installation
- (b) Testing, training and commissioning works.

SIGNATURE AND SPECIAL NOTES

Supplied as part of the contract for;

Supply, delivery, installation, testing, training and commissioning of Standby Generator Sets and Related Works in various health facilities.

PREPARED & ISSUED BY:

Amref Health Africa
P.O Box 30125 - 00100
Nairobi

The contract for the above-mentioned works entered into on the day of 20 by the undersigned parties, refers to these Bills of Quantities consisting and the Ministry of Works general specification dated 1976, (together with any amendments thereto issued since the date of publication) which shall be read and construed as part of the said contract.

.....
SUPPLIER

.....
CLIENT
AMREF HEALTH AFRICA

Date:

Date:

SPECIAL NOTES

The Supplier is required to check the pages of these Bills of Quantities together with all collections and summaries and should he find any missing or should the Supplier be in doubt of the precise meaning of any items of figures, for any reason whatsoever, he must inform the PROJECT MANAGER in order that the correct meaning may be decided before the date for submission of Tenders.

No liability will be admitted or claim allowed in respect of errors in the Supplier’s tender due to mistakes in the Bills of Quantities which should have been rectified in the manner described above.

The Bills of Quantities and General Specifications shall be read and construed together and wherever descriptions in the Bills of Quantities do not agree with descriptions in the General Specifications, then the Bills of Quantities shall override.

In the event of any discrepancies arising between the Bills of Quantities and actual works the site measurements shall generally take precedence. However, such discrepancies between any contract documents shall immediately be referred to the PROJECT MANAGER in accordance with Clause 22 of the conditions of Contract. The discrepancies shall then be treated as a variation and be dealt with in accordance with Clause 22 of the said Conditions.

TABLE OF CONTENTS

PART A: TECHNICAL REQUIREMENTS	1
SECTION I: Invitation to Tender	1
SECTION II: Instructions to Tenderers	4
SECTION III: Tender Evaluation Criteria	13
STAGE 1: Preliminary Evaluation	13
STAGE 2: Technical Evaluation	14
STAGE 3: Due Diligence	17
STAGE 4: Financial Evaluation	18
(a) Determination of Arithmetic Errors	18
(b) Comparison of rates	18
(c) Consistency of the Rates	18
SECTION IV: Conditions of Contract	19
SECTION V: Appendix to Conditions of Contract	35
SECTION VI: Standard Forms	37
Form of Invitation for Tenders	38
Form of Tender	39
Letter of Award	40
Form of Agreement	41
Form of Tender Security	43
Performance Bank Guarantee	44
Manufacturer's Authorization Form	45
Qualification Information	46
Confidential Business Questionnaire	48
Part 1 - General	48
Part 2 (a) – Individuals	48
Part 2 (b) – Partnership	48
Part 2 (c) – Registered Company	48
Details of Sub-Contractors	50
Declaration	51

PART A: TECHNICAL REQUIREMENTS

SECTION I: Invitation to Tender

1. Amref Health Africa invites sealed bids from eligible candidates for the supply, delivery, installation, testing, training and commissioning of Standby Generator Sets and related works in various health facilities in Kenya in lots as listed below;

Table 1:

LOT	DESCRIPTION	DELIVERY LOCATION	COUNTY
1	Supply, delivery, installation, testing, training and commissioning of 110 ±5 kVA Standby Generator Sets and related works	Lunga Lunga Sub County Hospital	Kwale
		Faza Sub County Hospital	Lamu
		Mpeketoni Sub County Hospital	Lamu
		Ngao Subcounty Hospital	TanaRiver
		Banisa Sub County Hospital	Mandera
		Bura Sub County Hospital	Garissa
		Daadab Sub County Hospital	Garissa
2	Supply, delivery, installation, testing, training and commissioning of 110 ±5 kVA Standby Generator Sets and related works	Kabartonjo Sub County Hospital	West Pokot
		Kacheliba Sub County Hospital	West Pokot
		Lokitaung Sub County hospital	Turkana
		Lokori Sub County Hospital	Turkana
		Chemolingot Sub County Hospital	Baringo
3	Supply, delivery, installation, testing, training and commissioning of 110 ±5 kVA Standby Generator Sets and related works	Kalacha Sub County Referral Hospital	Marsabit
		Rumuruti Sub County Hospital	Laikipia
		Suguta Marmar Sub County Hospital	Samburu
		Wamba Subcounty Hospital	Samburu
4	Supply, delivery, installation, testing, training and commissioning of 165 ±5 kVA Standby Generator Sets and related works	Habaswein Sub County Hospital	Wajir
		Ijara Subcounty Hospital	Garissa
5	Supply, delivery, installation, testing, training and commissioning of 200 ±5 kVA Standby Generator Sets and related works	Kapenguria CRH	West Pokot

2. This tender document is only for **Lot Number Two (2)**.
3. Interested eligible bidders may obtain further information from the **Amref Health Africa website** www.amref.org
4. Complete sets of tender documents can be downloaded from Amref Health Africa website; <http://amref.org/tenders/> by interested bidders upon payment of non-refundable fee of **Ksh.2000 PER LOT**. The payment should be made through the following Bank account(s): **Kenya Commercial Bank, Kipande House Branch, Account No: 1111429243 OR National**

Bank of Kenya, Wilson Branch, Account No: 01020058235400 or via MPesa Paybill: 890750, Account: AMREF/26/02/2025/006.

5. Candidates will then attach the copy of the mobile money receipt or the banking/deposit slip to the tender documents as proof of purchase. Candidates interested in buying more than one lot **Must** pay for the lots separately and then attach the copy of the mobile money receipts or banking deposit slips respectively to the tender documents as proof of purchase.
6. Completed tender documents for preliminary and technical requirements are to be enclosed in a plain envelope marked with the tender reference number and tender name. The financial bid **MUST** be in a separate envelope marked with the tender reference number, tender name, vendors name and vendors contact details. The financial bid will only be opened for those bidders who will have qualified in the technical evaluation). Please note that only one complete tender document per lot is required (Do not provide additional copies per lot).
7. tender documents for preliminary, technical requirements are to be enclosed in a plain envelope marked with the tender reference number and tender name. **Please note that only one complete tender document per lot is required (Do not provide additional copies per lot).**
8. Tenders must be delivered to the address below not later than **Wednesday 12th March 2025 at 12.00 noon** and must be accompanied by a tender security of **KShs 270,000.00** in the Currency specified in the tender document in the form of a bank guarantee from a reputable bank and must be delivered with the Tender Documents in the technical bid, **(bid bonds from insurance companies will NOT be accepted)**. The tender security validity period from date of closing tender should also be indicated.
9. Tenders should be dropped at the Amref Health Africa Kenya Country Office Tender Box at the Main Reception. Tenders will be opened at 12 noon on the closing date in the presence of the Tenderers' representatives who choose to attend at the Amref Health Africa Kenya Country Office. Electronic bidding will not be permitted. No bids will be accepted after 12 noon on the closing day.
10. Prices quoted should be inclusive of VAT and all other applicable taxes and must be in Kenya Shillings and shall remain valid for 90 days from the closing date of the tender.

NOTE: Global Fund grants are tax exempt. Bidders will be required to submit quotations inclusive of 16% VAT. Payment(s) to the successful bidder(s) shall be made in total exclusive of VAT and tax exemption certificate will be issued accordingly. Successful applicants shall be required to submit proforma invoice and valid tax compliance certificate upon receipt of LPO for processing of specific VAT exemption certificate.

11. Pre-Bid Conference

Interested eligible bidders are also invited for a pre-bid conference to be on **Friday 28th February 2025** starting at **10:00 am**. To access the Link for registration for the pre-bid conference, log onto Amref Health Africa website <http://amref.org/tenders/>

12. Specific Instructions

- 12.1 Bidders must quote for all items and quantities as indicated per Lot in order to qualify for evaluation.
- 12.2 The final bound tender document must be serially paginated (All pages in the document from top page (immediately after top cover) to the last page (one before back cover) including table of content, separators, brochures, bank deposit slip and any other attachments) in a continuous ascending order from the first page to the last in this format; 1,2,3.....n where n indicates the last numerical page number.
- 12.3 Should the reverse side of any leaf have content, it will also be considered as a page and should also be paginated.
- 12.4 Any alterations to the page numbering in the bid document must be clearly countersigned by the bidder. Failure to countersign such modifications shall render the bid non-compliant to the pagination requirement clause 11.2.
- 12.5 Any secondary attachment to a page (such as bank deposit slips/receipts etc.) should be glued onto that page. Stapling of secondary attachments is not allowed and may render your bid non-responsive.
- 12.6 Bids will be evaluated on Lot by Lot basis.

Amref Health Africa reserves the right to accept or reject any or all bids and is not bound to give reasons for its decision.

SECTION II: Instructions to Tenderers

1. General/Eligibility/Qualifications/Joint venture/Cost of tendering.
 - 1.1 The Employer as defined in the Appendix to Conditions of Contract invites tenders for Works Contract as described in the tender documents. The successful tenderer will be expected to complete the Works by the Intended Completion Date specified in the tender documents.
 - 2.1 All tenderers shall provide the Qualification Information, a statement that the tenderer (including all members of a joint venture and subcontractors) is not associated, or has not been associated in the past, directly or indirectly, with the Consultant or any other entity that has prepared the design, specifications, and other documents for the project or being proposed as Project Manager for the Contract. A firm that has been engaged by the Employer to provide consulting services for the preparation or supervision of the Works, and any of its affiliates, shall not be eligible to tender.
 - 3.1 All tenderers shall provide in the Form of Tender and Qualification Information, a preliminary description of the proposed work method and schedule as necessary.
 - 4.1 In the event that pre-qualification of potential tenderers has been undertaken, only tenders from pre-qualified tenderers will be considered for award of Contract. These qualified tenderers should submit with their tenders any information updating their original pre-qualification applications or, alternatively, confirm in their tenders that the originally submitted pre-qualification information remains essentially correct as of the date of tender submission.
 - 5.1 Where no pre-qualification of potential tenderers has been done, all tenderers shall include the following information and documents with their tenders, unless otherwise stated:
 - a) copies of original documents defining the constitution or legal status, place of registration, and principal place of business; written power of attorney of the signatory of the tender to commit the tenderer.
 - b) total monetary value of construction work performed for each of the last five years;
 - c) experience in works of a similar nature and size for each of the last five years, and details of work under way or contractually committed; and names and addresses of clients who may be contacted for further information on these contracts;
 - d) major items of construction equipment proposed to carry out the Contract and an undertaking that they will be available for the Contract.
 - e) qualifications and experience of key site management and technical personnel proposed for the Contract and an undertaking that they shall be available for the Contract.
 - f) reports on the financial standing of the tenderer, such as profit and loss statements and auditor's reports for the past two years;
 - g) evidence of adequacy of working capital for this Contract (access to line(s) of credit and availability of other financial resources);
 - h) authority to seek references from the tenderer's bankers;
 - i) information regarding any litigation, current or during the last five years, in which the tenderer is involved, the parties concerned and disputed amount; and

- j) proposals for subcontracting components of the Works amounting to more than 10 percent of the Contract Price.

6.1 Tenders submitted by a joint venture of two or more firms as partners shall comply with the following requirements, unless otherwise stated:

- a) Provide a Joint Venture Agreement. A legally binding agreement must be submitted outlining the roles, responsibilities, and contributions of each party.
- b) Provide proof of registration for the Joint Venture or Special Purpose Vehicle. the tender shall include all the information listed in clause 1.5 above for each joint venture partner;
- c) the tender shall be signed so as to be legally binding on all partners;
- d) all partners shall be jointly and severally liable for the execution of the Contract in accordance with the Contract terms;
- e) one of the partners will be nominated as being in charge, authorized to incur liabilities, and receive instructions for and on behalf of all partners of the joint venture; and
- f) the execution of the entire Contract, including payment, shall be done exclusively with the partner in charge.

7.1 To qualify for award of the Contract, tenderers shall meet the following minimum qualifying criteria;

- a) annual volume of construction work of at least 2.5 times the estimated annual cash flow for the Contract;
- b) experience as main Supplier in the construction of at least two completed works of a nature and complexity equivalent to the Works over the last 5 years;
- c) proposals for the timely acquisition (own, lease, hire, etc.) of the essential equipment listed as required for the Works;
- d) a team lead with at least seven years' experience in works of an equivalent nature and volume and;
- e) liquid assets and/or credit facilities, net of other contractual commitments and exclusive of any advance payments which may be made under the Contract, of no less than 4 months of the payment flow under this Contract.

8.1 The figures for each of the partners of a joint venture or shall be added together to determine the tenderer's compliance with the minimum qualifying criteria of clause 1.7 (a) and (e); however, for a joint venture to qualify, each of its partners must meet at least 25 percent of minimum criteria 1.7 (a), (b) and (e) for an individual tenderer, and the partner in charge at least 40 percent of those minimum criteria. Failure to comply with this requirement will result in rejection of the joint venture's tender. SubContractors' experience and resources will be taken into account in determining the tenderer's compliance with the qualifying criteria.

9.1 Each tenderer shall submit only one tender, either individually or as a partner in a joint venture. A tenderer who submits or participates in more than one tender (other than as a subSupplier or in cases of alternatives that have been permitted or requested) will cause all the proposals with the tenderer's participation to be disqualified.

- 10.1 The tenderer shall bear all costs associated with the preparation and submission of his tender, and the Employer will in no case be responsible or liable for those costs.
- 11.1 Tenderers who have been blacklisted or whose contracts with the procuring entity have been terminated for non-performance in the last 2 years prior to the date of the tender advertisement are not eligible to participate in the tender.
- 12.1 The procuring entity's employees, committee members, board members and their relatives (spouse and children) are not eligible to participate in the tender.
- 13.1 The price to be charged for the tender document shall be **Kshs. 2,000.00/= Per Lot.**
- 14.1 The procuring entity shall allow the tenderer to review the tender document free of charge before purchase through the website.

2. Tender Documents

- 1.1 The complete set of tender documents comprises the documents listed below and any addenda issued in accordance with Clause 2.4.
- a) These Instructions to Tenderers
 - b) Form of Tender and Qualification Information
 - c) Conditions of Contract
 - d) Appendix to Conditions of Contract
 - e) Specifications
 - f) Bills of Quantities
 - g) Forms of Securities
- 2.1 The tenderer shall examine all Instructions, Forms to be filled and Specifications in the tender documents. Failure to furnish all information required by the tender documents, or submission of a tender not substantially responsive to the tendering documents in every respect will be at the tenderer's risk and may result in rejection of his tender.
- 3.1 Enquiries from prospective tenderers shall be addressed during the Pre-bid conference to be held on **Friday 28th February 2025.**
- 4.1 Before the deadline for submission of tenders, the Employer may modify the tendering documents by issuing an addendum. Any addendum thus issued shall be part of the tendering documents and shall be communicated in writing or email to all tenderers. Prospective tenderers shall acknowledge receipt of each addendum in writing to the Employer.
- 5.1 To give prospective tenderers reasonable time in which to take an addendum into account in preparing their tenders, the Employer shall extend, as necessary, the deadline for submission of tenders, in accordance with Clause 4.2 here below.

3. Preparation of Tenders

- 1.1 All documents relating to the tender and any correspondence shall be in English language.
- 2.1 The final bound tender document must be serially paginated (All pages in the document from top page (immediately after top cover) to the last page (one before back cover) including table of content, separators, brochures, bank deposit slip and any other attachments) in a continuous ascending order from the first page to the last in this format; 1,2,3.....n where n is the last

numerical page number.

3.1 The document should be clearly arranged with separators and bound.

4.1 The tender submitted by the tenderer shall comprise the following:

- (a) These Instructions to Tenderers, Form of Tender, Conditions of Contract,
- (b) Appendix to Conditions of Contract and Specifications;
- (c) Tender Security;
- (d) Qualification Information Form and Documents;
- (e) Alternative offers where invited; and
- (f) Any other materials required to be completed and submitted by the tenderers.

5.1 The tenderer shall fill in rates and prices for all items of the Works described in the Bill of Quantities. Items for which no rate or price is entered by the tenderer will not be paid for when executed and shall be deemed covered by the other rates and prices in the Bill of Quantities. All duties, taxes, and other levies payable by the Supplier under the Contract, or for any other cause relevant to the Contract, as of 30 days prior to the deadline for submission of tenders, shall be included in the tender price submitted by the tenderer.

6.1 The rates and prices quoted by the tenderer shall only be subject to adjustment during the performance of the Contract if provided for in the Appendix to Conditions of Contract and provisions made in the Conditions of Contract.

7.1 The unit rates and prices shall be in Kenya Shillings.

8.1 Tenders shall remain valid for a period of Ninety (90) from the date of submission. However, in exceptional circumstances, the Employer may request that the tenderers extend the period of validity for a specified additional period. The request and the tenderers' responses shall be made in writing. A tenderer may refuse the request without forfeiting the Tender Security. A tenderer agreeing to the request will not be required or permitted to otherwise modify the tender, but will be required to extend the validity of Tender Security for the period of the extension, and in compliance with Clause 3.9 to 3.13 in all respects.

9.1 The tenderer shall furnish, as part of the tender, a Tender Security in the amount and form specified in the appendix to invitation to tenderers. This shall be in the amount specified in this tender document.

10.1 The format of the Tender Security should be in accordance with the form of Tender Security included in Section V - Standard forms or any other form acceptable to the Employer. Tender Security shall be valid for 90 days beyond the validity of the tender.

11.1 Any tender not accompanied by an acceptable Tender Security shall be rejected. The Tender Security of a joint venture must define as "Tenderer" all joint venture partners and list them in the following manner: a joint venture consisting of "....."
".....", and ".....".

12.1 The Tender Securities of unsuccessful tenderers will be returned within 28 days of the end of the tender validity period specified in Clause 3.8.

13.1 The Tender Security of the successful tenderer will be discharged when the tenderer has signed the Contract Agreement and furnished the required Performance Security.

- 14.1 The Tender Security may be forfeited
- (a) if the tenderer withdraws the tender after tender opening during the period of tender validity;
 - (b) if the tenderer does not accept the correction of the tender price, pursuant to Clause 5.7;
 - (c) in the case of a successful tenderer, if the tenderer fails within the specified time limit to;
 - (i) sign agreement, or
 - (ii) furnish the required Performance Security

15.1 Tenderers shall submit offers that comply with the requirements of the tendering documents, including the basic technical design as indicated in the Specifications. Alternatives will not be considered, unless specifically allowed in the invitation to tender. If so allowed, tenderers wishing to offer technical alternatives to the requirements of the tendering documents must also submit a tender that complies with the requirements of the tendering documents, including the basic technical design as indicated in the Specifications. In addition to submitting the basic tender, the tenderer shall provide all information necessary for a complete evaluation of the alternative, including design calculations, technical specifications, breakdown of prices, proposed construction methods and other relevant details. Only the technical alternatives, if any, of the lowest evaluated tender conforming to the basic technical requirements shall be considered.

16.1 The tenderer shall only submit one completed tender document per lot as described in Clause 3.4 of these Instructions to Tenderers, and containing the Form of Tender, and **clearly marked with the tender reference number and tender name**. (Do not provide additional copies per lot).

17.1 The submitted tender shall be typed or written in indelible ink and shall be signed by a person or persons duly authorised to sign on behalf of the tenderer, pursuant to Clause 1.5 (a) or 1.6 (b), as the case may be. All pages of the tender where alterations or additions have been made shall be initialled by the person or persons signing the tender.

18.1 Clarification of tenders shall be made during the Pre-bid conference to be held on **Friday 28th February 2025**.

19.1 The tender security shall be in the amount of **KShs 270,000.00**.

4. Submission of Tenders.

1.1 The tenderer shall seal the original of the tender in one envelope, duly marked. The envelope shall:

- (a) be addressed to the Employer at the address provided in the invitation to tender;
- (b) bear the tender name and tender reference number of the Contract as defined in the invitation to tender; and
- (c) provide a warning not to open before the specified time and date for tender opening.

2.1 Tenders shall be delivered to the Employer at the address specified above not later than the time and date specified in the invitation to tender. However, the Employer may extend the deadline for submission of tenders by issuing an amendment in accordance with Sub-Clause 2.5 in which case all rights and obligations of the Employer and the tenderers previously subject to the original

deadline will then be subject to the new deadline.

3.1 Any tender received after the deadline prescribed in clause 4.2 will be returned to the tenderer unopened.

4.1 Tenderers may modify or withdraw their tenders by giving notice in writing before the deadline prescribed in clause 4.2. Each tenderer's modification or withdrawal notice shall be prepared, sealed, marked, and delivered in accordance with clause 3.15 and 4.1, with the outer and inner envelopes additionally marked "MODIFICATION" and "WITHDRAWAL", as appropriate. No tender may be modified after the deadline for submission of tenders.

5.1 Withdrawal of a tender between the deadline for submission of tenders and the expiration of the period of tender validity specified in the invitation to tender or as extended pursuant to Clause 3.8 may result in the forfeiture of the Tender Security pursuant to Clause 3.13.

6.1 Tenderers may only offer discounts to, or otherwise modify the prices of their tenders by submitting tender modifications in accordance with Clause 4.4 or be included in the original tender submission.

5. Tender Opening and Evaluation

1.1 The tenders will be opened by the Employer, including modifications made pursuant to Clause 4.4, in the presence of the tenderers' representatives who choose to attend at the time and in the place specified in the invitation to tender. Envelopes marked "WITHDRAWAL" shall be opened and read out first. Tenderers' and Employer's representatives who are present during the opening shall sign a register evidencing their attendance.

2.1 The tenderers' names and proof of purchase of each tender and any alternative tender (if alternatives have been requested or permitted), tender modifications and withdrawals, and such other details as may the Employer, at its discretion may consider appropriate will be announced at the opening. The Employer shall prepare a tender opening report.

3.1 Information relating to the examination, clarification, evaluation, and comparison of tenders and recommendations for the award of Contract shall not be disclosed to tenderers or any other third parties out of the context of the evaluation committee until the award to the successful tenderer has been announced. Any effort by a tenderer to influence the Employer's officials, processing of tenders or award decisions shall result in the rejection of his tender.

4.1 To assist in the examination, evaluation, and comparison of tenders, the Employer at his discretion, may ask any tenderer for clarification of the tender, including breakdowns of unit rates. The request for clarification and the response shall be in writing or email but no change in the price or substance of the tender shall be sought, offered, or permitted except as required to confirm the correction of arithmetic errors discovered in the evaluation of the tenders in accordance with Clause 5.7.

5.1 Prior to the detailed evaluation of tenders, the Employer will determine whether each tender (a) meets the eligibility criteria defined in Clause 1.7; (b) has been properly signed; (c) is accompanied by the required securities; and (d) is substantially responsive to the requirements of the tendering documents. A substantially responsive tender is one which conforms to all the terms, conditions and specifications of the tendering documents, without material deviation or reservation. A material deviation or reservation is one (a) which affects in any substantial way the scope, quality, or performance of the works; (b) which limits in any substantial way, inconsistent with the tendering documents, the Employer's rights or the tenderer's obligations under the Contract; or (c) whose rectification would affect unfairly the competitive position of other tenderers presenting

substantially responsive tenders.

6.1 If a tender is not substantially responsive, it will be rejected, and may not subsequently be made responsive by correction or withdrawal of the nonconforming deviation or reservation.

7.1 Tenders determined to be substantially responsive will be checked for any arithmetic errors. Errors will be corrected as follows:

- (a) where there is a discrepancy between the amount in figures and the amount in words, the amount in words will prevail; and
- (b) where there is a discrepancy between the unit rate and the line item total resulting from multiplying the unit rate by the quantity, the unit rate as quoted will prevail, unless in the opinion of the Employer, there is an obvious typographical error, in which case the adjustment will be made to the entry containing that error.
- (c) In the event of a discrepancy between the tender amount as stated in the Form of Tender and the corrected tender figure in the main summary of the Bill of Quantities, the amount as stated in the Form of Tender shall prevail.
- (d) The Error Correction Factor shall be computed by expressing the difference between the tender amount and the corrected tender sum as a percentage of the corrected Work (i.e. Corrected tender sum less Prime Cost and Provisional Sums).
- (e) The Error Correction Factor shall be applied to all Works (as a rebate or addition as the case may be) for the purposes of valuations for Interim Certificates and valuation of variations.
- (f) the amount stated in the tender will be adjusted in accordance with the above procedure for the correction of errors and, with concurrence of the tenderer, shall be considered as binding upon the tenderer. If the tenderer does not accept the corrected amount, the tender may be rejected and the Tender Security may be forfeited in accordance with clause 3.13.

8.1 The Employer will evaluate and compare only the tenders determined to be substantially responsive in accordance with Clause 5.5.

9.1 In evaluating the tenders, the Employer will determine for each tender the evaluated tender price by adjusting the tender price as follows:

- (a) making any correction for errors pursuant to clause 5.7;
- (b) excluding provisional sums and the provision, if any, for contingencies in the Bill of Quantities, but including Dayworks where priced competitively.
- (c) making an appropriate adjustment for any other acceptable variations, deviations, or alternative offers submitted in accordance with clause 3.14; and
- (d) making appropriate adjustments to reflect discounts or other price modifications offered in accordance with clause 4.6.

10.1 The Employer reserves the right to accept or reject any variation, deviation, or alternative offer. Variations, deviations, and alternative offers and other factors which are in excess of the requirements of the tender documents or otherwise result in unsolicited benefits for the Employer will not be taken into account in tender evaluation.

11.1 The tenderer shall not influence the Employer on any matter relating to his tender from the time of the tender opening to the time the Contract is awarded. Any effort by the Tenderer to influence the Employer or his employees in his decision on tender evaluation, tender comparison or Contract award may result in the rejection of the tender.

12.1 Firms incorporated in Kenya where indigenous Kenyans own 51% or more of the share capital shall be allowed a 10% preferential bias provided that they do not sub-contract work valued at more than 50% of the Contract Price excluding Provisional Sums to a non-indigenous Sub-Contractor.

6. Award of Contract

1.1 Subject to Clause 6.2, the award of the Contract will be made to the tenderer whose tender has been determined to be substantially responsive to the tendering documents and who has offered the lowest evaluated tender price, provided that such tenderer has been determined to be (a) eligible in accordance with the provision of Clauses 1.2, and (b) qualified in accordance with the provisions of clause 1.7 and 1.8.

2.1 Notwithstanding clause 6.1 above, the Employer reserves the right to accept or reject any tender, and to cancel the tendering process and reject all tenders, at any time prior to the award of Contract, without thereby incurring any liability to the affected tenderer or tenderers or any obligation to inform the affected tenderer or tenderers of the grounds for the action.

3.1 The tenderer whose tender has been accepted will be notified of the award prior to expiration of the tender validity period in writing or email. This notification (hereinafter and in all Contract documents called the "Letter of Acceptance") will state the sum (hereinafter and in all Contract documents called the "Contract Price") that the Employer will pay the Supplier in consideration of the execution, completion, and maintenance of the Works by the Supplier as prescribed by the Contract. At the same time the other tenderers shall be informed that their tenders have not been successful. The contract shall be formed on the parties signing the contract.

4.1 The Agreement will incorporate all agreements between the Employer and the successful tenderer.

5.1 The LPO together with the contract will be sent to the successful tenderer if they acknowledge receipt and acceptance of the offer within 5 days following the date of notification of award. After receipt of the Letter of Acceptance, the successful tenderer shall deliver to the Employer a Performance Security in the amount stipulated in the Appendix to Conditions of Contract and in the form stipulated in the Tender documents. The Performance Security shall be in the amount and specified form.

6.1 Failure of the successful tenderer to comply with the requirements of clause 6.5 shall constitute sufficient grounds for cancellation of the award and forfeiture of the Tender Security.

7.1 Preference where allowed in the evaluation of tenders shall not be allowed for contracts not exceeding one year (12 months).

8.1 The tender evaluation shall be carried out within a maximum of 30 calendar days from the day of opening the tender.

9.1 The parties to the contract shall have it signed within 30 days from the date of notification of contract award unless there is an administrative review request.

10.1 Contract price variations shall not be allowed for contracts not exceeding one year (12 months).

11.1 Where contract price variation is allowed, the valuation shall not exceed 15% of the original contract price.

12.1 Price variation request shall be processed by the procuring entity within 14 days of receiving the request.

13.1 The procuring entity may at any time terminate procurement proceedings before contract award and shall not be liable to any person for the termination.

14.1 The procuring entity shall give prompt notice of the termination to the tenderers and on request give its reasons for termination within 14 days of receiving the request from any tenderer.

15.1 A tenderer who gives false information in the tender document about its qualification or who refuses to enter into a contract after notification of contract award shall be considered for debarment from participating in future public procurement.

7. Corrupt and Fraudulent practices

1.1 The procuring entity requires that tenderers observe the highest standards of ethics during procurement process and execution of contracts. A tenderer shall sign a declaration that he has not and will not be involved in corrupt and fraudulent practices.

8. Appeal Period

1.1 Any vendor/service provider who wishes to appeal against the outcome of the tender shall do so in writing within working 3 days of the date of the notification/regret letter. Any letter received after the third day shall not be responded to and shall be treated as null and void. Amref Health Africa shall have dispensed with this procurement. □

SECTION III: Tender Evaluation Criteria

After tender opening, the tenders will be evaluated in 4 stages, namely:

1. Preliminary Evaluation
2. Technical Evaluation – Part A
3. Technical Evaluation – Part B
4. Due diligence
5. Financial Evaluation

STAGE 1: Preliminary Evaluation

Bids will be evaluated based on the below criteria and the bids **lacking any of the documents** below will be considered as non-responsive and therefore will be eliminated at this stage.

Table 2:

PRELIMINARY EVALUATION OF MANDATORY REQUIREMENTS				
Mandatory Requirements				
No.	Particulars	Marks	Compliant	Non-compliant
1.	Copy of Certificate of Incorporation/Certificate of Registration	1 or 0		
2.	Copy of valid KRA Tax Compliance certificate	1 or 0		
3.	Copy of CR12 generated within the last 12 months (not older than January 2024)	1 or 0		
4.	Must attach Mobile money deposit receipt/banking deposit slip as proof of purchase of tender documents	1 or 0		
5.	Must provide a copy of Valid business Trading License	1 or 0		
6.	Must provide Manufacturer's certificate (if bidding as the manufacturer) or Manufacturer's authorization (if not the manufacturer) for the proposed Generator	1 or 0		
7.	Must provide tender security from a reputable bank amounting to KShs 270,000.00 valid up to Monday 25th August 2025	1 or 0		
8.	Must submit copies of 2 most recent sequential audited financial reports (from 2022) and each must be signed and dated by the auditor and the firms Directors. (Both reports must have unqualified/unmodified auditor's opinion).	1 or 0		
9.	Must provide Energy and Petroleum Regulatory Authority (EPRA) valid license for Electrical Contractors; (Class A2).	1 or 0		
10.	ENSURE that all pages are sequentially paginated in the format 1, 2,3 starting with 1 on top page (<i>see details of pagination and binding on section 11.2,11.3,11.4 and 11.5 of the tender document</i>).	1 or 0		

Note:

All the above documents numbered 1 to 10 should be packaged and arranged in that order under the preliminary evaluation criteria section of the tender document.

STAGE 2: Technical Evaluation

The tender document shall be examined based on clause 2.2 of the Instruction to Tenderers which states as follows:

1. In accordance with clause 2.2 of Instruction to Tenderers, the tenderers will be required to provide evidence for eligibility of the award of the tender by satisfying the employer of their eligibility under sub clause 2.1 of Instructions to Tenderers and their capability and adequacy of resources to effectively carry out the subject contract.
2. In order to comply with provisions of clause 2.2 of Instruction to Tenderers, the tenderers shall be required;
 - a) To fill the Standard Forms provided in the bid document for the purposes of providing the required information. The tenderers may also attach the required information if they so desire;
 - b) To supply equipment/items which comply with the technical specifications set out in the bid document. In this regard, the bidders shall be required to submit relevant technical brochures/catalogues with the tender document, highlighting the Catalogue Numbers of the proposed items. Such brochures/catalogues should indicate comprehensive relevant data of the proposed equipment/items which should include but not limited to the following:
 - (i) Standards of manufacture;
 - (ii) Performance ratings/characteristics;
 - (iii) Material of manufacture;
 - (iv) Electrical power ratings;
 - (v) Proof of CE Certification of the product; and
 - (vi) Any other necessary requirements (Specify)
 - (vii) Equipment compatibility restrictions with the rest of the electrical system/Installation.

The bid will then be analyzed, using the information in the technical brochures, to determine compliance with General and Particular technical specifications for the works as indicated in the tender document.

The tenderer shall also fill in the Technical Schedule as specified in the tender document for Equipment and Items indicating the Country of Origin, Model/Make/Manufacturer and catalogue numbers of the Items/Equipment they propose to supply.

Only bidders who shall meet the mandatory requirement of Part A of the technical evaluation shall proceed to the Part B of technical evaluation.

Table 3: Technical Evaluation

Requirements			
PART A			
Compliance with Technical Specifications for the following key components;			
	Description of requirements		Max Score
1	Diesel Engine Soundproof Canopied Generator –110 ±5 (standby rated) as per detailed specifications	Must Attach the diesel genset (engine and alternator) technical product data sheet/manual/brochure from the manufacturer evidencing the required Output)	10 or 0
		Fill ALL details as provided in schedule 2 (pg 69/70) and submit this with the bid or highlight these details in the product brochure/ data sheet	10 or 0
		TOTAL	20 OR 0
Bidders must score a total of 20 marks in PART A to qualify for PART B of technical evaluation			
PART B			
2	Annual Turnover (2 most recent audited financial reports from 2022); i. Average Annual Turn-over equal or greater than the cost of the project. (4 marks) ii. Average Annual Turn-over above 50% but below 100% of the cost of the project - (2 marks) iii. Average Annual Turn-over below 50% of the cost of the project (1 mark)		4 Marks
3	Manufacturer’s Warranty	Provide manufacturer’s warranty for at least 2 years from date of commissioning for the Generator (5mks)	5 marks
4	Maintenance Schedule	Attach the proposed comprehensive maintenance schedule in the form of a chart for servicing the equipment in all facilities listed in the specified lot listing the parts, tools, spares and consumables to be used during the 2-year warranty period.	2 marks
5	Spare parts guarantee	Provide letter of commitment from the manufacturer that generator spare parts will be available for at least 10 years after commissioning.	5 marks
6	Delivery Schedule	Attach a work program/delivery schedule in the form of a Gantt chart specifying the lead time for the supply, delivery, installation and commissioning of the gensets and related works for all facilities in this Lot. i. 16 weeks or less (3 marks) ii. More than 16 weeks (2marks) iii. Not specified (0 mark)	3 Marks

7	Proof of Supply of Generators	Provide proof of supply, installation and commissioning of power generators within the last 5 years – 2019 to date specifying the value including generator capacities (<i>purchase orders/invoices/contracts /completion certificates</i>) <ul style="list-style-type: none"> i. More than 10M- (5marks) ii. Less than 10M but more than 5M – (2 marks) iii. Less than 5M – (1 mark) iv. Not provided/Irrelevant – (0 mark) 	5Marks
8	Provide proof that the proposed generator manufacturer has local representation in Kenya for maintenance/servicing <ul style="list-style-type: none"> i. Provided (5 mks) ii. Not Provided (0 mk) 		5 Marks
9	Provide applicants litigation History- if any (attach Sworn affidavit by a lawyer) <ul style="list-style-type: none"> i. Provided/Declared (1 mark) ii. Not provided (0 mark) 		1 Mark
SUB TOTAL			30 MARKS
TOTAL			50 MARKS
Any bidder who scores at least 40 Marks out of 50 Marks in part B shall qualify for the next stage of due diligence.			

STAGE 3: Due Diligence

The Evaluation Committee shall subject shortlisted bidder(s) who pass the technical evaluation for due diligence process prior to the final stage of financial evaluation.

Shortlisted bidder(s) or their manufacturers shall be contacted to provide the below additional requirements:

- i. **Provide proof of conformance to ISO 9001** for the manufacture of Diesel engine generators
- ii. **Provide proof of conformance to ISO 8528** for Reciprocating Internal Combustion Engine Driven Alternating Current Generator Sets

STAGE 4: Financial Evaluation

Upon completion of the due diligence, a detailed financial evaluation shall follow prior to award.

The evaluation shall be in three stages;

- a) Determination of Arithmetic errors
- b) Comparison of Rates; and
- c) Consistency of the Rates.

(a) Determination of Arithmetic Errors

Arithmetic Errors will be corrected by the Procuring Entity as follows:

- i. In the event of a discrepancy between the tender amount as stated in the form of Tender and the corrected tender figure in the Main summary of the Bills of Quantities, the amount as stated in the Form of Tender shall prevail. Pursuant to Section 82 of the Public Procurement and Asset Disposal Act 2015, the tender sum as submitted and read out during the tender opening shall be absolute and final and shall not be the subject of correction, adjustment or amendment in any way by any person or entity;
- ii. Error correction factor shall be computed by expressing the difference between the amount and the corrected tender sum as a percentage of the corrected contract works (i.e. corrected tender sum less P.C; and Provisional Sums);
- iii. The Error correction factor shall be applied to all contract works (as a rebate or addition as the case may be) for the purposes of valuations for Interim Certificates and valuation of variations.

(b) Comparison of rates

Items that are under-priced or overpriced may indicate potential for non-delivery and front loading respectively. The committee shall promptly write to the tenderer asking for detailed breakdown of costs for any of the quoted items, relationship between those prices, proposed construction/installation methods and schedules.

The evaluation committee shall evaluate the responses and make an appropriate recommendation to the procuring entity giving necessary evidence. Such recommendations may include but not limited to:

- i. Recommend no adverse action to the tenderer after a convincing response;
- ii. Employer requiring that the amount of the performance bond be raised at the expense of the successful tenderer to a level sufficient to protect the employer against potential financial losses;
- iii. Recommend non-award based on the response provided and the available demonstrable evidence that the scope, quality, completion timing, administration of works to be undertaken by the tenderer, would adversely be affected or the rights of the employer or the tenderers obligations would be limited in a substantial way.

(c) Consistency of the Rates

The evaluation committee will compare the consistency of rates for similar items and note all inconsistencies of the rates for similar items.

SECTION IV: Conditions of Contract

1 Definitions

1.1 In this Contract, except where context otherwise requires, the following terms shall be interpreted as indicated;

“Bill of Quantities” means the priced and completed Bill of Quantities forming part of the tender.

“Compensation Events” are those defined in Clause 24 hereunder.

“The Completion Date” means the date of completion of the Works as certified by the Project Manager, in accordance with Clause 31.

“The Contract” means the agreement entered into between the Employer and the Supplier as recorded in the Agreement Form and signed by the parties including all attachments and appendices thereto and all documents incorporated by reference therein to execute, complete, and maintain the Works,

“The Supplier” refers to the person or corporate body whose tender to carry out the Works has been accepted by the Employer.

“The Supplier’s Tender” is the completed tendering document submitted by the Supplier to the Employer.

“The Contract Price” is the price stated in the Letter of Acceptance and thereafter as adjusted in accordance with the provisions of the Contract.

“Days” are calendar days; “Months” are calendar months.

“A Defect” is any part of the Works not completed in accordance with the Contract.

“The Defects Liability Certificate” is the certificate issued by Project Manager upon correction of defects by the Supplier.

“The Defects Liability Period” is the period named in the Contract Data and calculated from the Completion Date.

“Drawings” include calculations and other information provided or approved by the Project Manager for the execution of the Contract.

“Dayworks” are Work inputs subject to payment on a time basis for labour and the associated materials and plant.

“Client”, or the “Procuring entity” as defined in the Public Procurement Regulations (i.e. National or County Government administration, Universities, Public Institutions and Corporations, etc) is the party who employs the Supplier to carry out the Works.

“Equipment” is the Supplier’s machinery and vehicles brought temporarily to the Site for the execution of the Work.

“The Intended Completion Date” is the date on which it is intended that the Supplier shall complete the Works. The Intended Completion Date may be revised only by the Project Manager by issuing an extension of time or an acceleration order.

“Materials” are all supplies, including consumables, used by the Supplier for incorporation in the Works.

“Plant” is any integral part of the Works that shall have a mechanical, electrical, chemical, or biological function.

“Project Manager” is the person named in the Appendix to Conditions of Contract (or any other competent person appointed by the Employer and notified to the Supplier, to act in replacement of the Project Manager) who is responsible for supervising the execution of the Works and administering the Contract.

“Site” is the area defined as such in the Appendix to Condition of Contract.

“Site Investigation Reports” are those reports that may be included in the tendering documents which are factual and interpretative about the surface and subsurface conditions at the Site.

“Specifications” means the Specifications of the Works included in the Contract and any modification or addition made or approved by the Project Manager.

“Start Date” is the latest date when the Supplier shall commence execution of the Works. It does not necessarily coincide with the Site possession date(s).

“A SubSupplier” is a person or corporate body who has a Contract with the Supplier to carry out a part of the Work in the Contract, which includes Work on the Site.

“Temporary works” are works designed, constructed, installed, and removed by the Supplier which are needed for construction or installation of the Works.

“A Variation” is an instruction given by the Project Manager which varies the Works.

“The Works” are what the Contract requires the Supplier to construct, install, and turnover to the Employer, as defined in the Appendix to Conditions of Contract.

2 Interpretation

2.1 In interpreting these Conditions of Contract, singular also means plural, male also means female or neuter, and the other way around. Headings have no significance. Words have their normal meaning in English Language unless specifically defined. The Project Manager will provide instructions clarifying queries about these Conditions of Contract.

2.2 If sectional completion is specified in the Appendix to Conditions of Contract, reference in the Conditions of Contract to the Works, the Completion Date and the Intended Completion Date apply to any section of the Works (other than references to the Intended Completion Date for the whole of the Works).

2.3 The following documents shall constitute the Contract documents and shall be interpreted in the following order of priority;

- i. Agreement,
- ii. Letter of Acceptance,
- iii. Supplier's Tender,
- iv. Appendix to Conditions of Contract,
- v. Conditions of Contract,
- vi. Specifications,
- vii. Bill of Quantities,
- viii. Any other documents listed in the Appendix to Conditions of Contract as forming part of the Contract.

2.4 Immediately after the execution of the Contract, the Project Manager shall furnish both the Client and the Supplier with two copies each of all the Contract documents. Further, as and when necessary the Project Manager shall furnish the Supplier [always with a copy to the Client] with three [3] copies of such further details or descriptive schedules as are reasonably necessary either to enable the Supplier to carry out and complete the Works in accordance with these Conditions.

3 Language and Law

3.1 Language of the Contract and the law governing the Contract shall be English language and the Laws of Kenya respectively unless otherwise stated.

4 Project Manager's Decisions

4.1 Except where otherwise specifically stated, the Project Manager will decide contractual matters between the Employer and the Supplier in the role representing the Employer.

5 Delegation

5.1 The Project Manager may delegate any of his duties and responsibilities to others after notifying the Supplier.

6 Communications

6.1 Communication between parties shall be effective only when in writing. A notice shall be effective only when it is delivered.

7 Subcontracting

7.1 The Supplier may subcontract with the approval of the Project Manager, but may not assign the Contract without the approval of the Employer in writing. Subcontracting shall not alter the Supplier's obligations.

8 Other Contractors

8.1 The Supplier shall cooperate and share the Site with other Contractors, public authorities, utilities etc. as listed in the Appendix to Conditions of Contract and also with the Employer, as per the directions of the Project Manager. The Supplier shall also provide facilities and services for them. The Employer may modify the said List of Other Contractors etc., and shall notify the Supplier of any such modification.

9 Personnel

9.1 The Supplier shall employ the key personnel named in the Qualification Information, to carry out

the functions stated in the said Information or other personnel approved by the Project Manager. The Project Manager will approve any proposed replacement of key personnel only if their relevant qualifications and abilities are substantially equal to or better than those of the personnel listed in the Qualification Information. If the Project Manager asks the Supplier to remove a person who is a member of the Supplier's staff or work force, stating the reasons, the Supplier shall ensure that the person leaves the Site immediately days and has no further connection with the Work in the Contract.

10 Works

10.1 The Supplier shall construct and install the Works in accordance with the Specifications and Drawings. The Works may commence on the Start Date and shall be carried out in accordance with the Program submitted by the Supplier, as updated with the approval of the Project Manager, and complete them by the Intended Completion Date.

11 Safety and Temporary Works

11.1 The Supplier shall be responsible for the design of temporary works. However before erecting the same, he shall submit his designs including specifications to the Project Manager and to any other relevant third parties for their approval. No erection of temporary works shall be done until such approvals are obtained.

11.2 The Project Manager's approval shall not alter the Supplier's responsibility for design of the Temporary works prepared by the Supplier for the execution of the temporary or permanent Works, shall be subject to prior approval by the Project Manager before they can be used.

11.3 The Supplier shall be responsible for the safety of all activities on the Site.

11.4 Occupational Safety and Health Administration (OSHA). The Supplier will be required to comply with OSHA requirements during installation works. The Supplier will be required to provide risk assessment and safety methods statements prior to work commencement.

12 Discoveries

12.1 Anything of historical or other interest or of significant value unexpectedly discovered on Site shall be the property of the Employer. The Supplier shall notify the Project Manager of such discoveries and carry out the Project Manager's instructions for dealing with them.

13 Work Program

13.1 Within the time stated in the Appendix to Conditions of Contract, the Supplier shall submit to the Project Manager for approval a program showing the general methods, arrangements, order, and timing for all the activities in the Works. An update of the program shall be a program showing the actual progress achieved on each activity and the effect of the progress achieved on the timing of the remaining Work, including any changes to the sequence of the activities.

13.2 The Supplier shall submit to the Project Manager for approval an updated program at intervals no longer than the period stated in the Appendix to Conditions of Contract. If the Supplier does not submit an updated program within this period, the Project Manager may withhold the amount stated in the said Appendix from the next payment certificate and continue to withhold this amount until the next payment after the date on which the overdue program has been

submitted. The Project Manager's approval of the program shall not alter the Supplier's obligations. The Supplier may revise the program and submit it to the Project Manager again at any time. A revised program shall show the effect of Variations and Compensation Events.

14 Possession of Site

14.1 The Employer shall give possession of all parts of the Site to the Supplier. If possession of a part is not given by the date stated in the Appendix to Conditions of Contract, the Employer will be deemed to have delayed the start of the relevant activities, and this will be a Compensation Event.

15 Access to Site

15.1 The Supplier shall allow the Project Manager and any other person authorized by the Project Manager, access to the Site and to any place where work in connection with the Contract is being carried out or is intended to be carried out.

16 Instructions

16.1 The Supplier shall carry out all instructions of the Project Manager which are in accordance with the Contract.

17 Extension or Acceleration of Completion Date

17.1 The Project Manager shall extend the Intended Completion Date if a Compensation Event occurs or a variation is issued which makes it impossible for completion to be achieved by the Intended Completion Date without the Supplier taking steps to accelerate the remaining Work, which would cause the Supplier to incur additional cost. The Project Manager shall decide whether and by how much to extend the Intended Completion Date within 21 days of the Supplier asking the Project Manager in writing for a decision upon the effect of a Compensation Event or variation and submitting full supporting information. If the Supplier has failed to give early warning of a delay or has failed to cooperate in dealing with a delay, the delay caused by such failure shall not be considered in assessing the new (extended) Completion Date.

17.2 No bonus for early completion of the Works shall be paid to the Supplier by the Employer.

18 Management Meetings

18.1 A Contract management meeting shall be held monthly and attended by the Project Manager and the Supplier. Its business shall be to review the plans for the remaining Work and to deal with matters raised in accordance with the early warning procedure. The Project Manager shall record the minutes of management meetings and provide copies of the same to those attending the meeting and the Employer. The responsibility of the parties for actions to be taken shall be decided by the Project Manager either at the management meeting or after the management meeting and stated in writing to all who attended the meeting.

19 Early Warning

19.1 The Supplier shall warn the Project Manager at the earliest opportunity of specific likely future events or circumstances that may adversely affect the quality of the Work, increase the Contract Price or delay the execution of the Works. The Project Manager may require the Supplier to provide an estimate of the expected effect of the future event or circumstance on the Contract Price and Completion Date. The estimate shall be provided by the Supplier as soon as reasonably

possible.

- 19.2 The Supplier shall cooperate with the Project Manager in making and considering proposals on how the effect of such an event or circumstance can be avoided or reduced by anyone involved in the Work and in carrying out any resulting instructions of the Project Manager.

20 Defects

- 20.1 The Project Manager shall inspect the Supplier's work and notify the Supplier of any defects that are found. Such inspection shall not affect the Supplier's responsibilities. The Project Manager may instruct the Supplier to search for a defect and to uncover and test any Work that the Project Manager considers may have a defect. Should the defect be found, the cost of uncovering and making good shall be borne by the Supplier, However, if there is no defect found, the cost of uncovering and making good shall be treated as a variation and added to the Contract Price.
- 20.2 The Project Manager shall give notice to the Supplier of any defects before the end of the Defects Liability Period, which begins at Completion, and is defined in the Appendix to Conditions of Contract. The Defects Liability Period shall be extended for as long as defects remain to be corrected.
- 20.3 Every time notice of a defect is given, the Supplier shall correct the notified defect within the length of time specified by the Project Manager's notice. If the Supplier has not corrected a defect within the time specified in the Project Manager's notice, the Project Manager will assess the cost of having the defect corrected by other parties and such cost shall be treated as a variation and be deducted from the Contract Price.

21 Bills of Quantities

- 21.1 The Bills of Quantities shall contain items for the construction, installation, testing and commissioning of the Work to be done by the Supplier. The Supplier will be paid for the quantity of the Work done at the rate in the Bills of Quantities for each item.
- 21.2 If the final quantity of the Work done differs from the quantity in the Bills of Quantities for the particular item by more than 25 percent and provided the change exceeds 1 percent of the Initial Contract price, the Project Manager shall adjust the rate to allow for the change.
- 21.3 If requested by the Project Manager, the Supplier shall provide the Project Manager with a detailed cost breakdown of any rate in the Bills of Quantities.

22 Variations

- 22.1 All variations shall be included in updated programs produced by the Supplier.
- 22.2 The Supplier shall provide the Project Manager with a quotation for carrying out the variations when requested to do so. The Project Manager shall assess the quotation, which shall be given within seven days of the request or within any longer period as may be stated by the Project Manager and before the Variation is ordered.
- 22.3 If the work in the variation corresponds with an item description in the Bills of Quantities and if in the opinion of the Project Manager, the quantity of work is not above the limit stated in Clause

21.2 or the timing of its execution does not cause the cost per unit of quantity to change, the rate in the Bills of Quantities shall be used to calculate the value of the variation. If the cost per unit of quantity changes, or if the nature or timing of the work in the variation does not correspond with items in

22.4 The Bills of Quantities, the quotation by the Supplier shall be in the form of new rates for the relevant items of Work.

22.5 If the Supplier's quotation is unreasonable, the Project Manager may order the variation and make a change to the Contract price, which shall be based on the Project Manager's own forecast of the effects of the variation on the Supplier's costs.

22.6 If the Project Manager decides that the urgency of varying the Work would prevent a quotation being given and considered without delaying the Work, no quotation shall be given and the variation shall be treated as a Compensation Event.

22.7 The Supplier shall not be entitled to additional payment for costs that could have been avoided by giving early warning.

22.8 When the Program is updated, the Supplier shall provide the Project Manager with an updated cash flow forecast.

23 Payment Certificates, Currency of Payments and Advance Payments

23.1 The Supplier shall submit to the Project Manager monthly applications for payment giving sufficient details of the Work done and materials on Site and the amounts which the Supplier considers himself to be entitled to. The Project Manager shall check the monthly application and certify the amount to be paid to the Supplier within 14 days. The value of Work executed and payable shall be determined by the Project Manager.

23.2 The value of Work executed shall comprise the value of the quantities of the items in the Bills of Quantities completed, materials delivered on Site, variations and compensation events. Such materials shall become the property of the Employer once the Employer has paid the Supplier for their value. Thereafter, they shall not be removed from Site without the Project Manager's instructions except for use upon the Works.

23.3 Payments shall be adjusted for deductions for retention. The Employer shall pay the Supplier the amounts certified by the Project Manager within 30 days of the date of issue of each certificate. If the Employer makes a late payment, the Supplier shall be paid simple interest on the late payment in the next payment. Interest shall be calculated on the basis of number of days delayed at a rate three percentage points above the Central Bank of Kenya's average rate for base lending prevailing as of the first day the payment becomes overdue.

23.4 If an amount certified is increased in a later certificate or as a result of an award by an Arbitrator, the Supplier shall be paid interest upon the delayed payment as set out in this clause. Interest shall be calculated from the date upon which the increased amount would have been certified in the absence of dispute.

23.5 Items of the Works for which no rate or price has been entered in will not be paid for by the

Employer and shall be deemed covered by other rates and prices in the Contract.

23.6 The Contract Price shall be stated in Kenya Shillings. All payments to the Supplier shall be made in Kenya Shillings and foreign currency in the proportion indicated in the tender, or agreed prior to the execution of the Contract Agreement and indicated therein. The rate of exchange for the calculation of the amount of foreign currency payment shall be the rate of exchange indicated in the Appendix to Conditions of Contract. If the Supplier indicated foreign currencies for payment other than the currencies of the countries of origin of related goods and services, the Employer reserves the right to pay the equivalent at the time of payment in the currencies of the countries of such goods and services. The Employer and the Project Manager shall be notified promptly by the Supplier of any changes in the expected foreign currency requirements of the Supplier during the execution of the Works as indicated in the Schedule of Foreign Currency Requirements and the foreign and local currency portions of the balance of the Contract Price shall then be amended by agreement between Employer and the Supplier in order to reflect appropriately such changes.

23.7 In the event that an advance payment is granted, the following shall apply: -

- a) On signature of the Contract, the Supplier shall at his request, and without furnishing proof of expenditure, be entitled to an advance of 10% (ten percent) of the original amount of the Contract. The advance shall not be subject to retention money.
- b) No advance payment may be made before the Supplier has submitted proof of the establishment of deposit or a directly liable guarantee satisfactory to the Employer in the amount of the advance payment. The guarantee shall be in the same currency as the advance.
- c) Reimbursement of the lump sum advance shall be made by deductions from the Interim payments and where applicable from the balance owing to the Supplier. Reimbursement shall begin when the amount of the sums due under the Contract reaches 20% of the original amount of the Contract. It shall have been completed by the time 80% of this amount is reached.

The amount to be repaid by way of successive deductions shall be calculated by means of the formula:

$$R = \frac{A(x^1 - x^{11})}{80-20}$$

Where:

R = the amount to be reimbursed

A = the amount of the advance which has been granted

X¹ = the amount of proposed cumulative payments as a percentage of the original amount of the Contract. This figure will exceed 20% but not exceed 80%.

X^{11} = the amount of the previous cumulative payments as a percentage of the original amount of the Contract. This figure will be below 80% but not less than 20%.

- a) with each reimbursement the counterpart of the directly liable guarantee may be reduced accordingly.

24 Compensation Events

24.1 The following issues shall constitute Compensation Events:

- a) The Employer does not give access to a part of the Site by the Site Possession Date stated in the Appendix to Conditions of Contract.
- b) The Employer modifies the List of Other Contractors, etc., in a way that affects the Work of the Supplier under the Contract.
- c) The Project Manager orders a delay or does not issue drawings, specifications or instructions required for execution of the Works on time.
- d) The Project Manager instructs the Supplier to uncover or to carry out additional tests upon the Work, which is then found to have no defects.
- e) The Project Manager unreasonably does not approve a subcontract to be let.
- f) Ground conditions are substantially more adverse than could reasonably have been assumed before issuance of the Letter of Acceptance from the information issued to tenderers (including the Site investigation reports), from information available publicly and from a visual inspection of the Site.
- g) The Project Manager gives an instruction for dealing with an unforeseen condition, caused by the Employer or additional work required for safety or other reasons.
- h) Other Contractors, public authorities, utilities, or the Employer does not work within the dates and other constraints stated in the Contract, and they cause delay or extra cost to the Supplier.
- i) The effects on the Supplier of any of the Employer's risks.
- j) The Project Manager unreasonably delays issuing a Certificate of Completion.
- k) Other compensation events described in the Contract or determined by the Project Manager shall apply.

24.2 If a compensation event would cause additional cost or would prevent the Work being completed before the Intended Completion Date, the Contract Price shall be increased and/or the Intended Completion Date shall be extended. The Project Manager shall decide whether and by how much the Contract Price shall be increased and whether and by how much the Intended Completion Date shall be extended.

24.3 As soon as information demonstrating the effect of each compensation event upon the Supplier's

forecast cost has been provided by the Supplier, it shall be assessed by the Project Manager, and the Contract Price shall be adjusted accordingly. If the Supplier's forecast is deemed unreasonable, the Project Manager shall adjust the Contract Price based on the Project Manager's own forecast. The Project Manager will assume that the Supplier will react competently and promptly to the event.

- 24.4 The Supplier shall not be entitled to compensation to the extent that the Employer's interests are adversely affected by the Supplier not having given early warning or not having co-operated with the Project Manager.
- 24.5 Prices shall be adjusted for fluctuations in the cost of inputs only if provided for in the Appendix to Conditions of Contract.
- 24.6 The Supplier shall give written notice to the Project Manager of his intention to make a claim within thirty days after the event giving rise to the claim has first arisen. The claim shall be submitted within thirty days thereafter provided always that should the event giving rise to the claim of continuing effect, the Supplier shall submit an interim claim within the said thirty days and a final claim within thirty days of the end of the event giving rise to the claim.

25 Price Adjustment

- 25.1 The Project Manager shall adjust the Contract Price if taxes, duties and other levies are changed between the date 30 days before the submission of tenders for the Contract and the date of Completion. The adjustment shall be the change in the amount of tax payable by the Supplier.
- 25.2 The Contract Price shall be deemed to be based on exchange rates current at the date of tender submission in calculating the cost to the Supplier of materials to be specifically imported (by express provisions in the Contract Bills of Quantities or Specifications) for permanent incorporation in the Works. Unless otherwise stated in the Contract, if at any time during the period of the Contract exchange rates shall be varied and this shall affect the cost to the Supplier of such materials, then the Project Manager shall assess the net difference in the cost of such materials. Any amount from time to time so assessed shall be added to or deducted from the Contract Price, as the case may be.
- 25.3 Unless otherwise stated in the Contract, the Contract Price shall be deemed to have been calculated in the manner set out below and in sub-clauses 25.4 and 25.5 and shall be subject to adjustment in the events specified thereunder;
- i. The prices contained in the Contract Bills of Quantities shall be deemed to be based upon the rates of wages and other emoluments and expenses as determined by the Joint Building Council of Kenya (J.B.C.) and set out in the schedule of basic rates issued 30 days before the date for submission of tenders. A copy of the schedule used by the Supplier in his pricing shall be attached in the Appendix to Conditions of Contract.
 - ii. Upon J.B.C. determining that any of the said rates of wages or other emoluments and expenses are increased or decreased, then the Contract Price shall be increased or decreased by the amount assessed by the Project Manager based upon the difference, expressed as a percentage, between the rate set out in the schedule of basic rates issued 30 days before the date for submission of tenders and the rate published by the J.B.C.

and applied to the quantum of labour incorporated within the amount of Work remaining to be executed at the date of publication of such increase or decrease.

- iii. No adjustment shall be made in respect of changes in the rates of wages and other emoluments and expenses which occur after the date of Completion except during such other period as may be granted as an extension of time under clause 17.0 of these Conditions.

25.4 The prices contained in the Contract Bills of Quantities shall be deemed to be based upon the basic prices of materials to be permanently incorporated in the Works as determined by the J.B.C. and set out in the schedule of basic rates issued 30 days before the date for submission of tenders. A copy of the schedule used by the Supplier in his pricing shall be attached in the Appendix to Conditions of Contract.

25.5 Upon the J.B.C. determining that any of the said basic prices are increased or decreased then the Contract Price shall be increased or decreased by the amount to be assessed by the Project Manager based upon the difference between the price set out in the schedule of basic rates issued 30 days before the date for submission of tenders and the rate published by the J.B.C. and applied to the quantum of the relevant materials which have not been taken into account in arriving at the amount of any interim certificate under clause 23 of these Conditions issued before the date of publication of such increase or decrease.

25.6 No adjustment shall be made in respect of changes in basic prices of materials which occur after the date for Completion except during such other period as may be granted as an extension of time under clause 17.0 of these Conditions. The provisions of sub-clause 25.1 to 25.2 herein shall not apply in respect of any materials included in the schedule of basic rates.

26 Retention

26.1 The Employer shall retain from each payment due to the Supplier the proportion stated in the Appendix to Conditions of Contract until Completion of the whole of the Works. On Completion of the whole of the Works, half the total amount retained shall be repaid to the Supplier and the remaining half when the Defects Liability Period has passed and the Project Manager has certified that all defects notified to the Supplier before the end of this period have been corrected.

27 Liquidated Damages

27.1 The Supplier shall pay liquidated damages to the Employer at the rate stated in the Appendix to Conditions of Contract for each day that the actual Completion Date is later than the Intended Completion Date. The Employer may deduct liquidated damages from payments due to the Supplier. Payment of liquidated damages shall not alter the Supplier's liabilities.

27.2 If the Intended Completion Date is extended after liquidated damages have been paid, the Project Manager shall correct any overpayment of liquidated damages by the Supplier by adjusting the next payment certificate. The Supplier shall be paid interest on the overpayment, calculated from the date of payment to the date of repayment, at the rate specified in Clause 23.3.

28 Securities

28.1 The Performance Security shall be provided to the Employer no later than the date specified in

the Letter of Acceptance and shall be issued in an amount and form and by a reputable bank acceptable to the Employer, and denominated in Kenya Shillings. The Performance Security shall be valid until a date 30 days beyond the date of issue of the Certificate of Completion.

29 Dayworks

- 29.1 If applicable, the Dayworks rates in the Supplier's tender shall be used for small additional amounts of Work only when the Project Manager has given written instructions in advance for additional work to be paid for in that way.
- 29.2 All work to be paid for as Dayworks shall be recorded by the Supplier on Forms approved by the Project Manager. Each completed form shall be verified and signed by the Project Manager within two days of the Work being done.
- 29.3 The Supplier shall be paid for Dayworks subject to obtaining signed Dayworks forms.

30 Liability and Insurance

- 30.1 From the Start Date until the Defects Correction Certificate has been issued, the following are the Employer's risks: The risk of personal injury, death or loss of or damage to property (excluding the Works, Materials and Equipment), which are due to;
- i. use or occupation of the Site by the Works or for the purpose of the Works, which is the unavoidable result of the Works, or
 - ii. negligence, breach of statutory duty or interference with any legal right by the Employer or by any person employed by or contracted to him except the Supplier.
 - iii. the risk of damage to the Works, Plant, Materials, and Equipment to the extent that it is due to a fault of the Employer or in Employer's design, or due to war or radioactive contamination directly affecting the place where the Works are being executed.
- 30.2 From the Completion Date until the Defects Correction Certificate has been issued, the risk of loss of or damage to the Works, Equipment, and Materials is the Employer's risk except loss or damage due to;
- (a) a defect which existed on or before the Completion Date.
 - (b) an event occurring before the Completion Date, which was not itself the Employer's risk
 - (c) the activities of the Supplier on the Site after the Completion Date.
- 30.3 From the Start Date until the Defects Correction Certificate has been issued, the risks of personal injury, death and loss of or damage to property (including, without limitation, the Works, Plant, Materials, and Equipment) which are not Employer's risk are Supplier's risks.

The Supplier shall provide, in the joint names of the Employer and the Supplier, insurance cover from the Start Date to the end of the Defects Liability Period, in the amounts stated in the Appendix to Conditions of Contract for the following events;

- (a) loss of or damage to the Works, Plant, and Materials;
- (b) loss of or damage to Equipment;
- (c) loss of or damage to property (except the Works, Plant, Materials, and Equipment) in connection with the Contract, and
- (d) personal injury or death.

- 30.4 Policies and certificates for insurance shall be delivered by the Supplier to the Project Manager for the Project Manager's approval before the Start Date. All such insurance shall provide for compensation required to rectify the loss or damage incurred.
- 30.5 If the Supplier does not provide any of the policies and certificates required, the Employer may effect the insurance which the Supplier should have provided and recover the premiums from payments otherwise due to the Supplier or, if no payment is due, the payment of the premiums shall be a debt due.
- 30.6 Alterations to the terms of an insurance shall not be made without the approval of the Project Manager. Both parties shall comply with any conditions of insurance policies. Completion and taking over upon deciding that the Works are complete, the Supplier shall issue a written request to the Project Manager to issue a Certificate of Completion of the Works. The Employer shall take over the Site and the Works within seven [7] days of the Project Manager's issuing a Certificate of Completion.

31 Final Account

- 31.1 The Supplier shall issue the Project Manager with a detailed account of the total amount that the Supplier considers payable to him by the Employer under the Contract before the end of the Defects Liability Period. The Project Manager shall issue a Defects Liability Certificate and certify any final payment that is due to the Supplier within 30 days of receiving the Supplier's account if it is correct and complete. If it is not, the Project Manager shall issue within 30 days a schedule that states the scope of the corrections or additions that are necessary. If the final account is still unsatisfactory after it has been resubmitted, the Project Manager shall decide on the amount payable to the Supplier and issue a Payment Certificate. The Employer shall pay the Supplier the amount due in the Final Certificate within 60 days.

32 Termination

- 32.1 The Employer or the Supplier may terminate the Contract if the other party causes a fundamental breach of the Contract. These fundamental breaches of Contract shall include, but shall not be limited to, the following;
- (a) the Supplier stops work for 30 days when no stoppage of work is shown on the current program and the stoppage has not been authorized by the Project Manager;
 - (b) the Project Manager instructs the Supplier to delay the progress of the Works, and the instruction is not withdrawn within 30 days;
 - (c) the Supplier is declared bankrupt or goes into liquidation other than for a reconstruction or amalgamation;
 - (d) a payment certified by the Project Manager is not paid by the Employer to the Supplier within 30 days (for Interim Certificate) or 60 days (for Final Certificate) of issue.
 - (e) the Project Manager gives notice that failure to correct a particular defect is a fundamental breach of Contract and the Supplier fails to correct it within a reasonable period of time determined by the Project Manager;
 - (f) the Supplier does not maintain a security, which is required.
- 32.2 When either party to the Contract gives notice of a breach of Contract to the Project Manager for a cause other than those listed under Clause 33.1 above, the Project Manager shall decide whether

the breach is fundamental or not.

32.3 Notwithstanding the above, the Employer may terminate the Contract for convenience.

32.4 If the Contract is terminated, the Supplier shall stop work immediately, make the Site safe and secure, and leave the Site as soon as reasonably possible. The Project Manager shall immediately thereafter arrange for a meeting for the purpose of taking record of the Works executed and materials, goods, equipment and temporary buildings on Site.

33 Payment Upon Termination

33.1 If the Contract is terminated because of a fundamental breach of Contract by the Supplier, the Project Manager shall issue a certificate for the value of the Work done and materials ordered and delivered to Site up to the date of the issue of the certificate. Additional liquidated damages shall not apply. If the total amount due to the Employer exceeds any payment due to the Supplier, the difference shall be a debt payable by the Supplier.

33.2 If the Contract is terminated for the Employer's convenience or because of a fundamental breach of Contract by the Employer, the Project Manager shall issue a certificate for the value of the Work done, materials ordered, the reasonable cost of removal of equipment, repatriation of the Supplier's personnel employed solely on the Works, and the Supplier's costs of protecting and securing the Works.

33.3 The Employer may employ and pay other persons to carry out and complete the Works and to rectify any defects and may enter upon the Works and use all materials on the Site, plant, equipment and temporary works.

33.4 The Supplier shall, during the execution or after the completion of the Works under this clause remove from the Site as and when required, within such reasonable time as the Project Manager may in writing specify, any temporary buildings, plant, machinery, appliances, goods or materials belonging to or hired by him, and in default the Employer may (without being responsible for any loss or damage) remove and sell any such property of the Supplier, holding the proceeds less all costs incurred to the credit of the Supplier.

33.5 Until after completion of the Works under this clause the Employer shall not be bound by any other provision of this Contract to make any payment to the Supplier, but upon such completion as aforesaid and the verification within a reasonable time of the accounts therefore the Project Manager shall certify the amount of expenses properly incurred by the Employer and, if such amount added to the money paid to the Supplier before such determination exceeds the total amount which would have been payable on due completion in accordance with this Contract the difference shall be a debt payable to the Employer by the Supplier; and if the said amount added to the said money be less than the said total amount, the difference shall be a debt payable by the Employer to the Supplier.

34 Release from Performance

34.1 If the Contract is frustrated by the outbreak of war or by any other event entirely outside the control of either the Employer or the Supplier, the Project Manager shall certify that the Contract has been frustrated. The Supplier shall make the Site safe and stop Work as quickly as possible

after receiving this certificate and shall be paid for all Work carried out before receiving it.

35 Corrupt gifts and payments of commission

35.1 The Supplier shall not;

- (a) Offer or give or agree to give to any person in the service of the Employer any gift or consideration of any kind as an inducement or reward for doing or forbearing to do or for having done or forborne to do any act in relation to the obtaining or execution of this or any other Contract for the Employer or for showing or forbearing to show favour or disfavour to any person in relation to this or any other contract for the Employer.
- (b) Enter into this or any other contract with the Employer in connection with which commission has been paid or agreed to be paid by him or on his behalf or to his knowledge, unless before the Contract is made particulars of any such commission and of the terms and conditions of any agreement for the payment thereof have been disclosed in writing to the Employer.

Any breach of this Condition by the Supplier or by anyone employed by him or acting on his behalf (whether with or without the knowledge of the Supplier) shall be an offence under the provisions of the Public Procurement Regulations issued under The Exchequer and Audit Act Cap 412 of the Laws of Kenya.

36 Settlement of Disputes

36.1 In case any dispute or difference shall arise between the Employer or the Project Manager on his behalf and the Supplier, either during the progress or after the completion or termination of the Works, such dispute shall be notified in writing by either party to the other with a request to submit it to arbitration and to concur in the appointment of an Arbitrator within thirty days of the notice. The dispute shall be referred to the arbitration and final decision of a person to be agreed between the parties. Failing agreement to concur in the appointment of an Arbitrator, the Arbitrator shall be appointed by the Chairman or Vice Chairman of any of the following professional institutions;

- (i) Architectural Association of Kenya
- (ii) Institute of Quantity Surveyors of Kenya
- (iii) Association of Consulting Engineers of Kenya
- (iv) Chartered Institute of Arbitrators (Kenya Branch)
- (v) Institution of Engineers of Kenya

On the request of the applying party. The institution written to first by the aggrieved party shall take precedence over all other institutions.

36.2 The arbitration may be on the construction of this Contract or on any matter or thing of whatsoever nature arising thereunder or in connection therewith, including any matter or thing left by this Contract to the discretion of the Project Manager, or the withholding by the Project Manager of any certificate to which the Supplier may claim to be entitled to or the measurement and valuation referred to in clause 23.0 of these conditions, or the rights and liabilities of the parties subsequent to the termination of Contract.

36.3 Provided that no arbitration proceedings shall be commenced on any dispute or difference where notice of a dispute or difference has not been given by the applying party within ninety days of the occurrence or discovery of the matter or issue giving rise to the dispute.

- 36.4 Notwithstanding the issue of a notice as stated above, the arbitration of such a dispute or difference shall not commence unless an attempt has in the first instance been made by the parties to settle such dispute or difference amicably with or without the assistance of third parties. Proof of such attempt shall be required.
- 36.5 Notwithstanding anything stated herein the following matters may be referred to arbitration before the practical completion of the Works or abandonment of the Works or termination of the Contract by either party:
- 36.6 The appointment of a replacement Project Manager upon the said person ceasing to act.
- 36.7 Whether or not the issue of an instruction by the Project Manager is empowered by these Conditions.
- 36.8 Whether or not a certificate has been improperly withheld or is not in accordance with these Conditions.
- 36.9 Any dispute or difference arising in respect of war risks or war damage.
- 36.10 All other matters shall only be referred to arbitration after the completion or alleged completion of the Works or termination or alleged termination of the Contract, unless the Employer and the Supplier agree otherwise in writing.
- 36.11 The Arbitrator shall, without prejudice to the generality of his powers, have powers to direct such measurements, computations, tests or valuations as may in his opinion be desirable in order to determine the rights of the parties and assess and award any sums which ought to have been the subject of or included in any certificate.
- 36.12 The Arbitrator shall, without prejudice to the generality of his powers, have powers to open up, review and revise any certificate, opinion, decision, requirement or notice and to determine all matters in dispute which shall be submitted to him in the same manner as if no such certificate, opinion, decision requirement or notice had been given.
- 36.13 The award of such Arbitrator shall be final and binding upon the parties.

SECTION V: Appendix to Conditions of Contract

The Client is:

Name: Amref Health Africa

Address: P.O. Box 30125 - 00100 Nairobi

The Project Manager is:

Name:

Address:

The name (and identification number) of the Contract is the SUPPLY, DELIVERY, INSTALLATION, TESTING, TRAINING AND COMMISSIONING OF STANDBY GENERATOR SETS AND RELATED WORKS.

The Works consist of SUPPLY, DELIVERY, INSTALLATION, TESTING, TRAINING AND COMMISSIONING OF STANDBY GENERATOR SETS AND RELATED WORKS as per the specifications and Bills of Quantities.

The Start Date shall be agreed with the Project Manager.

The maximum Intended Completion Date for the whole of the Works shall be **16 Weeks** after commencement date.

The following documents also form part of the Contract as listed in clause 2.1 of the Conditions of Contract.

The Supplier shall submit a revised program for the Works within 7 days of delivery of the Letter of Acceptance.

The Site Possession Date shall be agreed with the Project Manager.

The Defects Liability period of 6 months will apply.

Other Contractors, utilities etc., to be engaged by the Client on the Site include those for the execution of; (Domestic SubContractors must be registered with NCA and evidence of the same must be attached)

1. Electrical Works
2. Mechanical Works

The minimum insurance covers shall be;

1. The minimum cover for insurance of the Works and of Plant and Materials in respect of the Supplier's faulty design is _____ Nil _____
2. The minimum cover for loss or damage to Equipment is _____ Nil
3. The minimum for insurance of other property is Kshs. 500,000.00
4. The minimum cover for personal injury or death insurance:
For the Supplier's employees is _____ Kshs. 500,000.00
And for other people is _____ Kshs. 1,000,000.00

The following events shall also be Compensation Events:

1. NONE OTHER THAN AS DEFINED IN THESE CONDITIONS OF CONTRACT
- 2.
- 3.
- 4.

The period between Program updates is 7 days.

The amount to be withheld for late submission of an updated Program is FULL CERTIFICATE

The proportion of payments retained is 10 percent (%).

The Price Adjustment Clause SHALL NOT apply.

The liquidated damages for the whole of the Works is Kshs. 10,000 [per Week].

The Performance Security shall be for the following minimum amounts equivalent as a percentage of the Contract Price 10 percent (%).

The Completion Period for the Works is 16 [Weeks].

The rate of exchange for calculation of foreign currency payments is NOT APPLICABLE

The schedule of basic rates used in pricing by the Supplier is as ISSUED BY THE JOINT BUILDING COUNCIL (JBC - KENYA) THIRTY DAYS BEFORE THE DATE OF SUBMISSION OF TENDERS

Advance Payment SHALL NOT APPLY.

The Bidder should submit only ONE (1 No.) set of the Bills of Quantities as indicated in clause 4.1 of the Instruction to Tenderers.

SECTION VI: Standard Forms

- 1) Form of Invitation for Tenders
- 2) Form of Tender
- 3) Letter of Award
- 4) Form of Agreement
- 5) Form of Tender Security
- 6) Performance Bank Guarantee
- 7) Manufacturer's Authorization Form
- 8) Bank Guarantee for Advance Payment
- 9) Qualification Information
- 10) Confidential Business Questionnaire
- 11) Details of Sub-Contractors

Form of Invitation for Tenders

_____ [date]

To: _____ [Name of Supplier]

_____ [Address of Supplier]

Dear Sirs:

Reference _____ [Contract Name]

You have been prequalified to tender for the above project.

We hereby invite you and other prequalified tenderers to submit a tender for the execution and completion of the above Contract.

A complete set of tender documents may be purchased by you from _____

[mailing address]

Upon payment of a non-refundable fee of Kshs _____

All tenders must be accompanied by _____ number of copies of the same and a security in the form and amount specified in the tendering documents, and must be delivered to

[address and location]

at or before _____

[time and date]

Tender will be opened immediately thereafter, in the presence of tenderer's representatives who choose to attend.

Please confirm receipt of this letter immediately in writing by email.

Yours faithfully,

_____ [Authorized Signature]

_____ [Name and Title]

Form of Tender

To: Amref Health Africa [Name of Client]

_____ [Date]

[Name of Contract]

Dear Sir,

In accordance with the Conditions of Contract, Specifications and Bills of Quantities for the execution of the above-named Works, we, the undersigned offer to construct, install and complete such Works and remedy any defects therein for the sum of Kshs

[Amount in Figures]

[Amount in Words]

We undertake, if our tender is accepted, to commence the Works as soon as is reasonably possible after the receipt of the Project Manager's notice to commence, and to complete the whole of the Works comprised in the Contract within the time stated in the Appendix to Conditions of Contract.

We agree to abide by this tender until . [Insert date], and it shall remain binding upon us and may be accepted at any time before that date.

Unless and until a formal Agreement is prepared and executed this tender together with your written acceptance thereof, shall constitute a binding Contract between us.

We understand that you are not bound to accept the lowest or any tender you may receive.

Dated this _____ day of _____ 20 _____

Signature _____ in the capacity of _____

Duly authorized to sign tenders on behalf of _____
[Name of the Supplier]

[Address of the Supplier]

Witness Name: _____

Address: _____

Signature: _____

Date: _____

Letter of Award

[letterhead paper of the Employer]
_____ [date]

To: _____
[name of the Contractor]

[address of the Contractor]

Dear Sir,

This is to notify you that your tender dated _____

[name of the Contract and tender number as given in the Tender documents] for the

Contract Price of Kshs. _____ [amount in figures] [Kenya Shillings]

[Amount in words] in accordance with the Instructions to Tenderers is hereby accepted.

You are hereby instructed to proceed with the execution of the said Works in accordance with the
Contract documents.

Authorized Signature

Name and Title of Signatory

Attachment: Agreement

Form of Agreement

THIS AGREEMENT, made on the _____ day of ____ 20 _____ between _____ of [or whose registered office is situated at] _____ (hereinafter called “the Client”) of the one part

AND

_____ of [or whose registered office is situated at] _____ (hereinafter called “the Supplier”) of the other part.

WHEREAS THE Employer is desirous that the Supplier executes _____ (name and identification number of Contract) (hereinafter called “the Works”) located at _____ [Place/location of the Works] and the Client has accepted the tender submitted by the Supplier for the execution and completion of such Works and the remedying of any defects therein for the Contract Price of Kshs _____ [Amount in figures], Kenya Shillings _____ [Amount in words].

NOW THIS AGREEMENT WITNESSETH as follows:

1. In this Agreement, words and expressions shall have the same meanings as are respectively assigned to them in the Conditions of Contract hereinafter referred to.
2. The following documents shall be deemed to form and shall be read and construed as part of this Agreement i.e.
 - a) Letter of Acceptance Form of Tender
 - b) Conditions of Contract Part I
 - c) Conditions of Contract Part II and Appendix to Conditions of Contract Specifications
 - d) Priced Bills of Quantities
3. In consideration of the payments to be made by the Client to the Supplier as hereinafter mentioned, the Supplier hereby covenants with the Employer to execute and complete the Works and remedy any defects therein in conformity in all respects with the provisions of the Contract.
4. The Employer hereby covenants to pay the Supplier in consideration of the execution and completion of the Works and the remedying of defects therein, the Contract Price or such other sum as may become payable under the provisions of the Contract at the times and in the manner prescribed by the Contract.

IN WITNESS, WHEREOF the Parties have caused this Agreement to be executed by their duly appointed representatives on the date first above-mentioned.

For and on Behalf of:

[Supplier's Name]
[Contractors Address]

Name

Position

Signature

Witness Name

Witness Signature

Witness Name

Witness Signature

Place Company Stamp Here

For and on Behalf of:

[Clients Name]
[Contractors Address]

Name

Position

Signature

Witness Name

Witness Signature

Witness Name

Witness Signature

Place Company Stamp Here

Form of Tender Security

Tender No. Amref

SUPPLY, DELIVERY, INSTALLATION, TESTING, TRAINING AND COMMISSIONING OF
STANDBY GENERATOR SETS AND RELATED WORKS – LOT NO 2

To: Amref Health Africa

WHEREAS *[insert: name of Tenderer]* (hereinafter called “the Tenderer”) has submitted its tender dated *[insert: date of tender]* for the performance of the above-named Contract (hereinafter called “the Tender”)

KNOW ALL PERSONS by these present that WE *[insert: name of bank]* of *[insert: address of bank]* (hereinafter called “the Bank”) are bound unto *[insert: name of Purchaser]* (hereinafter called “the Purchaser”) in the sum of: *[insert: amount]*, for which payment well and truly to be made to the said Purchaser, the Bank binds itself, its successors and assigns by these presents.

Sealed with the Common Seal of the said Bank this *[insert: number]* day of *[insert: month]*, *[insert: year]*.

THE CONDITIONS of this obligation are the following:

1. If, after the tender submission deadline, the Tenderer
 - (a) withdraws its tender during the period of tender validity specified by the Tenderer in the Tender Form, or
 - (b) does not accept the Purchaser’s corrections of arithmetic errors in accordance with the Instructions to Tenderers; or
 - (c) does not at all reply to the Purchaser’s requests for clarification
2. If the Tenderer, having been notified of the acceptance of its tender by the Purchaser during the period of tender validity.
 - (a) Fails or refuses to sign the Contract Agreement when required; or
 - (b) Fails or refuses to issue the performance security in accordance with the Instructions to Tenderers.

We undertake to pay to the Purchaser up to the above amount upon receipt of its first written demand, without the Purchaser having to substantiate its demand, provided that in its demand the Purchaser will note that the amount claimed by it is due it, owing to the occurrence of any one of the two above-named CONDITIONS, and specifying the occurred condition or conditions. This guarantee will remain in full force up to and including **Monday 25th August 2025** and any demand in respect thereof must reach the Bank not later than the above date.

Note: A bidder who withdraws its tender after the deadline for submission will forfeit its bid security deposit

For and on behalf of the Bank

Signed: _____ Date: _____

Performance Bank Guarantee

To: _____ [Name of Client]
_____ [Address of Client]
_____ [Date]

Dear Sir,

WHEREAS _____ (hereinafter called “the Supplier”) has undertaken, in pursuance of Contract No. _____ dated _____ to execute _____ (hereinafter called “the Works”);

AND WHEREAS it has been stipulated by you in the said Contract that the Supplier shall furnish you with a Bank Guarantee by a recognized bank for the sum specified therein as security for compliance with his obligations in accordance with the Contract;
AND WHEREAS we have agreed to give the Supplier such a Bank Guarantee:

NOW THEREFORE we hereby affirm that we are the Guarantor and responsible to you, on behalf of the Supplier, up to a total of Kshs. _____ (*amount of Guarantee in figures*) Kenya Shillings
_____ (*amount of Guarantee in words*), and we undertake to pay you, upon your first written demand and without cavil or argument, any sum or sums within the limits of Kenya Shillings _____ (amount of Guarantee in words) as aforesaid without your needing to prove or to show grounds or reasons for your demand for the sum specified therein.

We hereby waive the necessity of your demanding the said debt from the Supplier before presenting us with the demand.

We further agree that no change, addition or other modification of the terms of the Contract or of the Works to be performed thereunder or of any of the Contract documents which may be made between you and the Supplier shall in any way release us from any liability under this Guarantee, and we hereby waive notice of any change, addition, or modification.

This guarantee shall be valid until the date of issue of the Certificate of Completion.

SIGNATURE AND SEAL OF THE GUARANTOR

Name of Bank _____
Address _____
Date _____

Manufacturer's Authorization Form

(Must be on Manufacturer's or Producer's letterhead)

To. Amref Health Africa,
Opposite Langata Primary School,
P.O Box 30125-00100
Nairobi, Kenya

Dear Sirs,

WHEREAS [insert: name of the manufacturer or producer] (hereinafter, "we" or "us") who are established and reputable manufacturers or producers of [insert: name and/or description of the Goods requiring this authorization] (hereinafter, "Goods") having production facilities at [insert: address of factory] do hereby authorize [insert: name and address of Tenderer] (hereinafter, the "Tenderer") to submit a tender, and subsequently negotiate and sign the Contract with you against [insert: the specific tender name and lot number] For supply of generator sets and related works, including the above Goods produced by us.

We hereby extend our full guarantee and warranty for the above specified Goods against these tender documents.

For and on behalf of the Manufacturer or Producer

Signed: _____

Date: _____

In the capacity of [insert: title, position, or other appropriate designation] and duly authorize to sign this Authorization on behalf of [insert: name of manufacturer or producer]

NOTE: Manufacturer's Authorization must be ON LETTER HEAD and addressed to Amref Health Africa and must be specific to the tender and item and signed by an authorized signatory. - MANDATORY

Qualification Information

Individual Tenderers or Individual Members of Joint Ventures

- 1.1 Constitution or legal status of tenderer (attach copy or Incorporation Certificate);
 Place of registration: _____
 Principal place of business: _____
 Power of attorney of signatory of tender: _____

1.2 Total annual volume of construction work performed in the last five years

Year	Volume	
	Currency	Value

1.3 Work performed as Main Supplier on works of a similar nature and volume over the last five years. Also list details of work under way or committed, including expected completion date.

Project name	Name of the client and contact person	Type of work performed and year of completion	Value of Contract

1.4 Major items of Supplier’s Equipment proposed for carrying out the Works. List all information requested below.

Item of Equipment	Description, Make and age (years)	Condition (new, good, poor) and number available	Owned, leased (from whom?), or to be purchased (from whom?)

1.5 Qualifications and experience of key personnel proposed for administration and execution of the Contract. Attach biographical data.

Position	Name	Years of experience (general)	Years of experience in proposed position
Project Manager etc.)			

1.6 Financial reports for the last TWO years: balance sheets, profit and loss statements, auditor's reports, etc. List below and attach copies.

1.7 Evidence of access to financial resources to meet the qualification requirements: cash in hand, lines of credit, etc. List below and attach copies of supportive documents.

1.8 Name, address and telephone numbers of banks that may provide reference if contacted by the Employer.

1.9 Statement of compliance with the requirements of Clause 1.2 of the Instructions to Tenderers.

1.10 Proposed program (work method and schedule) for the whole of the Works.

Joint Ventures

The information listed in 1.1 – 1.10 above shall be provided for each partner of the joint venture. The following information shall also be provided for the joint venture;

1. Attach the power of attorney of the signatory(ies) of the tender authorizing signature of the tender on behalf of the joint venture
2. Attach the Agreement among all partners of the joint venture (and which is legally binding on all partners), which shows that:
 - a) all partners shall be jointly and severally liable for the execution of the Contract in accordance with the Contract terms;
 - b) one of the partners will be nominated as being in charge, authorized to incur liabilities and receive instructions for and on behalf of any and all partners of the joint venture; and
 - c) the execution of the entire Contract, including payment, shall be done exclusively with the partner in charge.

Confidential Business Questionnaire

You are requested to give the particulars indicated in part 1 and either part 2(a), 2(b), 2(c) or (2d) whichever applies to your type of business.

You are advised that it is a serious offence to give false information on this Form. (refer to clause 6.15)

Part 1 - General

Business Name:

Location of Business premises:

Country/Town.....

Postal Address:.....

Code: Town:

Tel No.:

E-mail:Fax:

Nature of Business:

Part 2 (a) – Individuals

Your Name in full:

Nationality: Country of Origin:

Citizenship details:

Part 2 (b) – Partnership

	Name	Nationality	Citizenship Details	Shares
1.
2.
3.

Part 2 (c) – Registered Company

Private or Public:.....

State the nominal and issue capital of the company.....

Nominal Kshs:

Issued Kshs:

Give details of all directors as follows:

Name	Nationality	Citizenship Details	Shares
------	-------------	---------------------	--------

1.
2.
3.

Details of Sub-Contractors

If the Tenderer wishes to sublet any portions of the Works under any heading, he must give below details of the sub-Contractors he intends to employ for each portion.

Failure to comply with this requirement may invalidate the tender.

- 1. Portion of Works to be sublet:
Full names of the Sub-Contractor:
Address and head office:
Sub-Contractor's experience of similar Works carried out in the last 3 years with contract value:
.....
.....
.....
.....

- 2. Portion of Works to be sublet:
.....
Full names of the Sub-Contractor:
Address and head office:
Sub-Contractor's experience of similar Works carried out in the last 3 years with contract value:
.....
.....
.....

[Signature of Tenderer]

[Date]

Declaration

I/We have completed this form (s) accurately at the time of reply and it is agreed that all responses can be substantiated, if requested to do so, and that any inaccuracy in the information filled herein will lead to disqualification of the tenderer.

For and behalf of:

Name:

Date: Signature

DETAILED SPECIFICATIONS

INTRODUCTION

This section specifies the general requirements for plant, equipment and materials forming part of the Contract Works and shall apply except where specifically stated elsewhere in the Specification or on the Contract Drawings.

QUALITY OF MATERIALS

All plant, equipment and materials supplied as part of the Sub-contract Works shall be new and of first class commercial quality, shall be free from defects and imperfections and where indicated shall be of grades and classifications designated herein.

All products or materials not manufactured by the Sub-Contractor shall be products of reputable manufacturers and so far as the provisions of the Specification is concerned shall be as if they had been manufactured by the Sub-Contractor.

Materials and apparatus required for the complete installation as called for by the Specification and Contract Drawings shall be supplied by the Sub-Contractor unless mention is made otherwise.

Materials and apparatus supplied by others for installation and connection by the Sub-Contractor shall be carefully examined on receipt via a checklist. Should any defects be noted, the Sub-Contractor shall immediately notify the Engineer.

Defective equipment or that damaged in the course of installation or tests shall be replaced as required to the approval of the Engineer.

1. REGULATIONS AND STANDARDS

STANDARDS; BRITISH STANDARDS INSTITUTION AND ISO EQUIVALENTS

- BS 7671:2018:2022 - applies to the design, selection, erection and verification of electrical installations within; residential properties; commercial .
- BS 5486 part 12- Low-Voltage Switchgear and Controlgear Assemblies ,Particular Requirements of Type- Tested Miniature Circuit-Breaker Boards.
- BS 3871- The Standard for Specification for miniature and moulded case circuit-breakers - Miniature air-break circuit-breakers for a.c. circuits.
- BS 6346- The Standard for Electric cables. PVC insulated, armoured cables for voltages of 600/1000 V and 1900/3300 V.
- BS 1442- Standard for the specification for Galvanized Mild Steel Wire for Armoring Cables.

- BS 6604 - Code of practice for safe operation of starter batteries. Safety and health aspects associated with the handling, usage and charging of batteries for starting the internal combustion engines.
- ISO 8528 part 3:2020 - Standard stating the reciprocating internal combustion engine driven alternating current generating sets - Requirements and tests for low-power generating sets.
- BS 4678, part 1 requirements - The Standard for Cable trunking. Specifies dimensions and performance requirements and a system of classification for cable trunking according to its material and properties.
- Manufacturing CE & ISO 9001 ISO 9001 Certification is crucial for manufacturing industries, especially organizations manufacturing tools, metal products, machinery parts, PC boards, other electrical products.: Demonstrate that your organization is customer-focused and committed to delivering consistent, quality products.

2. COMPLIANCE

The Contract Works shall comply with the current editions of the following: -

- a) The Kenya Government Regulations.
- b) The United Kingdom Institution of Electrical Engineers (IEE) Regulations for the Electrical Equipment of Buildings.
- c) The United Kingdom Chartered Institute of Building Services Engineers (CIBSE) Guides.
- d) British Standard and Codes of Practice as published by the British Standards Institution (BSI)
- e) The Local Council By-laws.
- f) The Electricity Supply Authority By-laws.
- g) County Government By-laws.
- h) The Kenya Building Code Regulations.
- i) The Kenya Bureau of Standards

3. Power Supply on Site

The supply voltage will be 240 volts single phase of 415 volts 3 phase 50 Hz. TN-S system, viz. separate neutral and protective conductor throughout the system.

4. EXTENT AND DESCRIPTION OF WORKS

4.1 Scope

The work covered by this specification includes the supply, delivery, installation, setting to work, train and commission to the satisfaction of the engineer and provide maintenance for a period of

twenty-four (24) months of one Diesel Engine Power Generating Set complete with all necessary auxiliary equipment and as indicated. The Supplier shall comply in all respects with the specifications, but the Supplier may offer alternatives provided that the differences and advantages are clearly detailed by him on the schedule of alternatives to be attached and returned with the tender. The Supplier will undertake training of users.

4.2 As-Installed Drawings

During the course of construction, the Supplier shall correct one copy of the contract drawings daily as the work proceeds, indicating any change made from the arrangement shown in the contract drawings.

This amended drawing shall remain on site, readily available for inspection, and the amendments must ultimately be transferred to a reproducible copy of the contract drawing.

5. RELATED DOCUMENTS

5.1 The specification shall be read in conjunction with the Preliminaries, conditions of contract and any supplementary specification(s) schedule(s) and drawing (s) issued with it and enumerated in the invitation to tender. In the event of a discrepancy between this specification and any drawing issued with it or forming part of the contract, the drawing shall be followed.

5.2 The words 'as indicated', 'where indicated', 'unless otherwise indicated' refer to items or requirements indicated elsewhere in the tender documents issued in connection with the contract e.g. on a drawing, in a supplementary specification or in Schedule 1.

6. REGULATIONS AND STANDARDS

The equipment shall comply with all relevant statutory standards and regulations current at the date of tender (unless otherwise indicated) and in particular the following:

- 1) I.E.E. Regulations for the Electrical Equipment of Buildings
- 2) Regulations under the Electrical Power Act
- 3) Factories Act
- 4) Any special regulations issued by the Local Electricity or Water Undertakings

The equipment and all components shall comply with all relevant British Standards and Codes of Practice or other equal and approved standard specifications and codes. Where the equipment or part of it complies with other internationally recognized standards, which are less stringent than British Standards or Codes of Practice, then the difference is to be stated in writing and must accompany the tender submission.

7. OPERATING CONDITIONS

7.1 The equipment and all components shall be suitable for operation in ambient conditions

of 50 to 400 centigrade and up to 100% relative humidity in an unheated open but roofed environment.

7.2 All ratings of equipment and components shall be interpreted as site ratings and NOT sea level or other ratings. Details of the site are given in **Section 1**.

7.3 The Supplier is deemed to have visited the site where the generator is to be placed as in Table 1.

7.4 The Supplier is deemed to have acquainted himself therewith as its nature, position, means of access, etc. and no claim in this connection will be allowed. No claim will be allowed for travelling or other expenses which may be incurred by the Supplier in visiting the site or preparing a tender for the contract works, and subsequent site visits to be called by the engineer during the contract period.

7.5 The set shall be capable of operating continuously and satisfactorily in a medium dust laden atmosphere as defined in BS 1701 and in accordance with BS 5514.

8. FUNCTIONAL REQUIREMENTS

8.1 The standby generator set shall be used for emergency operation (standby power operation). It shall be possible to start, operate and stop the set manually independently of any automatic features.

8.2 Within the operating conditions specified the set shall be capable of starting and accepting full load within the shortest possible time and in any case not more than 10 seconds. Any special features included to achieve this shall be stated.

9. PERFORMANCE

9.1 The output rating of the set in KVA, the voltage, the number of phases and the frequency shall be as specified in Schedule 1.

9.2 Within the operating conditions specified, each set, equipped with its standard air intake filters, shall be capable of delivering its rated output continuously at rated voltage and 0.8 lagging power factor and of delivering 10% in excess of the continuous maximum in accordance with 150 3046/1, As 2789, DIN 6271 and BS 5514.

9.3 The steady state voltage shall be maintained within 2½% of the rated voltage under the control of the voltage regulator between the cold start ambient conditions and the maximum working temperatures, at any load from no load to 10% overload and from unity to 0.8 lagging power factor.

9.4 After any change of load the voltage shall not vary by more than plus or minus 15% of the rated voltage and shall return to within plus/minus 3% within 3 seconds and to within

plus/minus 2.5% of rated voltage within 15 seconds. On starting the voltage overshoot shall not exceed 15% and shall return to within 3% in not more than 3 seconds.

9.5 The governing of the set shall be such that the steady load speed band shall not exceed 1% of rated speed. Sudden removal of the full load at rated frequency shall not cause the frequency to rise above 10% of rated frequency and it shall return to within 5% of rated frequency within 3 seconds. The resultant steady state frequency shall return to 4% within 15 seconds. If full load is then reimposed the frequency shall not fall below 94% of rated frequency and shall return to 99% within 3 seconds and to the rated frequency within 15 seconds.

9.6 The cyclic irregularity of the set at full load shall not be worse than 1/150

9.7 The deviation of the waveform of the voltage output from a pure sine wave shall not exceed the limits specified in BS 2613

9.8 Radiated interference shall be suppressed to the limits specified in B.S. 800 and B.S. 833.

10. SET ARRANGEMENT

10.1 The set and its auxiliaries shall be mounted on a sufficiently substantial underbase. All items which must be held in correct relative alignment shall be located by means of dowels.

10.2 The set shall be designed and supplied for operation bolted to the floor on robust anti vibration and shock absorbing devices. It shall have adjusting screws for optimum setting and levelling and be so designed and installed that no appreciable engine vibration shall be transmitted to the floor or to any surroundings.

10.3 A new generator house will be constructed. The Supplier shall provide early enough full details of fixing requirements, any modifications that may be necessary for the proposed house and foundation. Particularly, the Supplier appointed to supply the generator must confirm if the proposed house is adequate for the generator in terms of height, length, width and provision of natural ventilation. The Supplier will be responsible for cost of modifying the generator house if he fails to provide the above information immediately. The Supplier shall however provide means for bolting down the set. If the plinth provided is not sufficient the Supplier shall arrange to extend it to the Engineer's satisfaction.

10.4 Bearings shall be suitable for operation over long periods without the need for replacement of the lubricant. Oil lubricated bearings shall be fitted with a visible oil level gauge.

11. DIESEL ENGINE

Complying with ISO 8528: Standard for Reciprocating Internal Combustion Engine Driven Alternating Current Generator Sets As Follows:

11.1 The engine shall comply in design and performance with BS.649. The engine shall be

designed for satisfactory operation on fuel oil complying with BS 2869 Class D and the lubricating oils.

11.2 The governor shall control the frequency with the limits stated in section 7.4 manual speed adjustment shall be provided over a range + 5% of the rated speed at any load.

11.3 The engine shall be totally enclosed, with forced lubrication from an integral pump having on the suction side a coarse strainer and on the deliver side a dual 'full flow' fine filter fitted with a changeover cock incorporating pressure by-passes, so that the oil flow to the engine is maintained if the filter should chock.

11.4 A filter fitted with by-pass relief shall be inserted in the fuel line immediately before the pump(s). The fuel filter element shall be incapable of passing particles larger than 5 micrometers. The fuel system shall be so arranged that fuel resulting from filter, pump or pipe spillage shall be incapable of entering the engine pump.

11.5 Air filters complying with BS 1701, Grade 'A' or Grade 'B' / KS 06-294: 1986, Grade 'A' and Grade 'B' suitable for use in a dusty atmosphere shall be fitted on the engine air intake(s).

11.6 No significant critical speed of the complete shaft system, including the generator, shall be within 15% of the rated speed.

11.7 A manually reset overspeed trip shall be fitted to stop the engine if its speed exceeds the rated speed by 15%. A mechanical trip is preferred but an electrical overspeed trip may be offered. Both types shall be equipped with a pair of contacts which close on operating of the trip. If the device is belt driven, at least two belts shall be provided and the drive shall be capable of carrying full load with one belt removed.

11.8 The set shall be arranged such on shut-down the coolant temperature shall not rise with residual heat so that the high coolant temperature lock-out operates

11.9 The engine shall be naturally aspirated or turbo-charged

11.10 Starting shall be by means of electricity supplied from a starter battery. The starter motor shall be of the axial type, de-energized by a device operated from the engine.

11.11 Suitable means shall be provided for turning by hand the engine main shaft and the associated generator to facilitate inspection and overhaul. A means of manual starting is to be provided as indicated in Schedule No.1.

11.12 The engine shall be capable of being started from any crank position.

11.13 A thermostatically controlled 240 – volt immersion heater may be fitted in the engine lubricating oil sump to facilitate starting. The heating surface loading of any lubricating oil

heater(s) shall not exceed 0.015 watt per sq. millimeter to avoid carbonization of the oil.

11.14 An efficient exhaust silencer with adequate draining facilities shall be supplied, and as indicated in Schedule 1 shall be installed in the generator house with the exhaust discharge into the steel chimney. The exhaust silencer shall be so arranged that it may be readily relocated in required.

12. FUEL STORAGE TANK

12.1 The fuel storage tank shall be located at the base of the generator

12.2 A minimum capacity of the tank shall be a minimum of 200 litres.

12.3 Equipped with a water separator unit preceding the particulate filtration unit along the diesel supply line before the diesel injection system of the engine

12.4 Equipped with an anti-siphoning valve and lockable diesel tank cap

12.5 Equipped with fuel level sensor displaying on genset panel

13. ENGINE INSTRUMENTS

13.1 Following instruments shall be provided: -

a. A lubricating oil pressure gauge

b. A tachometer

c. A coolant thermometer

d. An exhaust gas pyrometer or thermometer mounted near the exhaust manifold.

e. Lubricating oil thermometers on the inlet to and outlet from the engine, when lubricating oil cooler is fitted.

f. Oil pressure gauge and fuel pressure gauge

14. COOLING SYSTEM

The engine shall be water-cooled /coolant cooled

15. ENGINE COOLING USING COOLANT

15.1 A radiator of the air blast type shall be provided. It shall either have separate section for coolant and for lubricating oil or be arranged for jacket coolant only.

15.2 Belt driven fans shall be provided with at least two belts and the drive shall be capable of transmitting the full load with one belt removed.

15.2 Circulation of the jacket coolant and lubricating oil through the respective radiator sections and or heat exchanger shall be by means of pumps mechanically driven by the engine. Belt driven pumps shall be provided with at least two belts and the drive shall be capable of transmitting the full load with one belt removed.

15.3 An easily visible flow indicator provided with contacts shall be fitted in the water outlet from the engine; the contacts shall close in the 'no-flow' condition and shut down the set. Alternatively in thermosyphon systems and scaled or pressurised radiator systems the flow indicator may be dispensed with providing the engine shuts shown by the operation of the high

temperature or low oil pressure safety devices.

15.4 A thermostatically controlled diverter valve shall be inserted in the engine water discharge pipe with a return to the circulating pump section, to maintain the circulating water at the optimum temperature irrespective of load. Alternatively a thermostatic by-pass shall be accepted.

15.5 A radiator makeup/expansion tank, fitted with float control inlet shall be provided: a sealed or pressurized unit is offered the tank shall be dispensed with.

15.6 Where indicated provision shall be made on the radiator framework to permit the attachment of ducting for the discharged air.

15.7 A thermometer shall be mounted near the cylinder head(s) to indicate water temperature. Where a lubricating oil cooler is fitted, inlet thermometers shall be mounted at the oil to and outlet from the engine. Alternatively, thermocouples may be provided at all thermometer positions and taken out to an instrument panel.

15.8 Adequate drains shall be provided at low points in the coolant and lubricating oil system of the radiator and, where applicable, of the heat exchanger.

16. ALTERNATOR AND EXCITER.

16.1 Alternator

16.1.1 The generator shall comply with B.S.2613:197, for service in tropical conditions, and shall withstand being idle for considerable periods without any harmful drop in the insulation resistance.

16.1.2 The generator set shall have a standby rated net output of as specified in the Table 1, at least 0.8 lagging power factor, 415 volts, 3 phase, 4- wire 50 Hertz with brushless rotating rectifier excitation system and voltage regulator. It shall be directly coupled to the engine and be sized such that it will accept the maximum output of the engine including overload.

16.1.3 The output voltage shall be maintained within plus or minus 2 ½ % from no load to full load conditions. The alternator shall be capable of operating within the range of plus or minus 15% of the nominal voltage according to the automatic voltage regulator.

16.1.4 Three phase machines shall be star connected, and a diagram showing the terminal marking and phase rotation shall be provided in the terminal box. Cables connecting the machine winding and machine terminals shall not have a higher derating factor for temperature than the windings.

16.1.5 The insulation shall comply with BS 2757 excluding Classes Y and A. The insulation shall have an oil, moisture and fungus proof finish, with a surface which will not retain dust or condensation. It shall be possible to put the set in service after long periods in unheated storage

without necessarily drying out the insulation.

16.1.6 The alternator shall be capable of withstanding a short circuit for three seconds when under the control of the automatic voltage regulator.

16.2 Excitation

16.2.1 Excitation shall be by means of brushless direct coupled exciter armature.

16.2.2 The alternators shall be designed for an excitation voltage at full load of not less than 50- Volts unless prior approval is given.

17. ELECTRICAL CONTROL PANEL

17.1 General

Generator control panel main features;

a. GENSET CONTROLS - is a microprocessor-based generator set monitoring, metering, protection and control system. It shall offer advanced levels of functions for reliability and optimum gen set performance. The control system shall have easy servicing capabilities that allow system parameters to be interrogated, monitored, and adjusted with a PC.

Features:

- Digital governing
- Digital voltage regulation
- Protection for true alternator O/C protection
- Analog/ digital AC output metering
- Battery monitoring system to sense and warn against a weak battery condition
- Digital alarm and status message display
- Gen set monitoring: Displays status of all critical engines and Generator set functions
- Smart starting control system: Integrated fuel ramping to limit black smoke and Frequency overshoot
- Advanced serviceability
- Network connectivity

b. The set is to be used for mains failure duty and an automatic starting panel shall be provided which shall contain all necessary equipment for controlling the automatic starting and stopping of the set, lubricating oil priming (if necessary), all auxiliaries, fault warnings and shut downs. All faults, warning and shut-downs shall be separately indicated. There shall be test facilities for indication lamps, etc. preferably by means of a single test button.

c. Means shall be provided for isolating all supplies to the starting panel either by an isolating switch or by withdrawable fuses. When the set is stopped other than under lock-out conditions,

it shall be self-resetting ready for the next start. The set shall be suitable for starting by manual means. E.g. by cranking or direct operation of the starter solenoid.

d. All switches and push buttons shall be clearly marked to indicate their function. It shall be possible to operate the 'Start' and 'Stop' buttons and to see the 'Set Failure' indications without opening the panel doors.

18. AUTOMATIC CHANGEOVER CONTROLS AND SELECTOR PANELS

18.1 The controls shall be installed and wired in the machine control panel. The control shall be provided such that on failure of the normal electricity supply, it will automatically initiate the starting off and effect the transfer of load to the generator. The selector panel will then monitor the loading of the generator. The schematic for the controls shall be approved by the Electrical Engineer before manufacture commences.

18.2 Where failure of the normal supply is referred to, it shall be defined as follows:

1. Complete loss of voltage in one line or in all the three lines
2. Falling of voltage below 85% of the normal voltage between two lines or line and neutral
3. Voltage overshoot to 110% of the normal voltage between two lines or line and neutral
4. Incorrect phase sequence.

18.3 On failure of the normal supply, the unit shall operate in the following manner:

a) After a delay, adjustable from 0 to 15 seconds (to avoid operation by a transient dip in voltage) a signal shall be given to start the standby generating set.

b) On receipt of a signal from the standby generating set that it is ready to take load, and providing that the failure of the normal supply still persists, the normal supply contactor in the control panel shall open and the standby contactor shall close. If the normal supply has been restored before the changeover has taken place, the contactor shall not operate and the starting relay contacts shall open to initiate the shutting down of the standby generating set.

18.4 When the standby supply is in operation and the normal supply is restored and remains within 10% of rated voltage on all phases for a pre-set time (adjustable up to 120 second) the standby contactor shall open and the normal supply contactor shall close; the starting relay contacts shall then open to shut down the generating set.

18.5 Provision shall be made so that automatic return to normal supply can be prevented if required. Once a start signal has been sent to standby generating set, the engine starting sequence shall be allowed to continue until the set is ready to take the load before a stopping signal is sent.

18.6 A push button labelled 'Test' shall be provided to enable a failure of normal supply to be simulated. If the button is pressed and released the equipment shall complete the starting sequence, and when the set is ready to take load it shall be shut down. If the button is held depressed the equipment shall change over to the standby supply when the set is ready to take load.

18.7 Indicating lamps or illuminated panels shall be provided on the front of the panel. They shall be appropriately labelled, easily visible and shall give the following information:

'Main Supply Available'

'Generator Supply Available'

'Mains Supply on load'

'Generator Supply on load'

19. AUTOMATIC STARTING PANEL

19.1 Automatic starting panel shall be provided which shall contain all necessary equipment for controlling the automatic starting and stopping of the set, lubricating oil priming (if necessary), auxiliaries, fault warnings and shut-downs. All faults, warnings and shutdowns shall be separately indicated. There shall be test facilities for indication lamps etc., preferably by means of a single test button.

19.2 Means shall be provided for isolating all supplies to the starting panel either by an isolating switch or by withdrawable fuses. For external use, a 24 v-volt battery supply from fused outlet terminals shall be provided only when the engine is running and in service from fused outlet terminals shall be provided only when the engine is running and in service

19.3 The starting and control circuits shall be rated at 2 amps at the control circuit voltage.

19.4 A selector switch shall be fitted having three positions as follows: -

19.4.1 'Local' In this position it shall be possible to start and stop the set by push buttons united on the panel.

19.4.2 'Remote' In this position the set shall be capable of being started and stopped from a remote circuit.

19.4.3 'Off' In this position all the automatic features shall be inoperative.

19.5 When the set is stopped other than under lock-cut conditions it shall be self-resetting, ready for the next start.

19.6 In the 'Off' position (Section 19.4.3) or with the automatic equipment disconnected, the set shall be suitable for starting by manual means, e.g. by cranking or direct operation of the starter solenoid.

20. ELECTRICAL CONTROL PANELS

A control panel shall be provided to accommodate the following: -

- 1) An automatic voltage regulator
- 2) A hand filled regulator and a 'HAND AUTO' switch
- 3) An alternator field switch
- 4) Meters (Section 24)
- 5) A neutral earthing link
- 6) A change-over – contactor

21. AUTOMATIC VOLTAGE REGULATOR

The automatic voltage regulator shall be of a type, which will maintain its adjustment for long period without attention. It shall be provided with an adjustment for setting the level of the controlled voltage to within + 5% of the nominal voltage.

22. HAND FILLED REGULATOR AND A 'HAND AUTO' SWITCH

22.1 The hand filled regulator shall give stable control of the voltage from 90% of the normal voltage at no load when cold to normal voltage at 10% over-load when hot, under the specified operating conditions.

If static excitation system is offered which does not permit the use of a hand filed regulator this shall be stated in the Tender together with performance details.

22.2 If the hand filled regulator must be left in a precise position when the set is under the control of the automatic voltage regulator then this position shall be clearly marked.

22.3 Auto hand switch shall be provided.

23. AN ALTERNATOR FIELD SWITCH

24. METERS

The following meters shall be provided. They shall comply with BS 89, Table 7

- 1) One maximum demand ammeter in each line
- 2) One voltmeter, and a selector switch to read line to line and line to neutral voltage
- 3) A frequency meter
- 4) A field ammeter
- 5) Maximum KVA meter and Kilowatt-hour meter

25.0 AUTOMATIC CHANGE OVER SWITCH (ATS)

25.1 The Automatic Mains Failure control panel shall be provided and fitted with the following:

- 25.1.1 Two four pole contactors and two TP & N incoming MCCB's each of suitable rating for controlling the supply from the mains transformer and standby generator
- 25.1.2 An automatic voltage regulator for the set.
- 25.1.3 Control equipment as necessary including phase failure protection relay for both the mains supply and the generator supply (with both under and over voltage protection) and phase sequence protection relay for the mains supply all to fulfill the functional requirements and automatic changeover.
- 25.1.4 One ammeter and a selector switch to measure each phase current and neutral current
- 25.1.5 One voltmeter and a selector switch to read line to line and line to neutral voltage
- 25.1.6 A frequency meter. The meters shall comply with BS 89.

25.2 AUTOMATIC OPERATION CONTROL UNIT

- 25.2.1 Where the functional requirements (see Section 4) indicate the set is to be used for automatic standby or mains failure duty a contactor unit shall be provided which on failure of the normal electricity supply will automatically initiate the starting of and effect the transfer of load to the prime rate generator. The unit shall be incorporated in the Automatic Starting Panel (see section 19)
- 25.2.2 The power circuit shall consist of two contactors feeding the distribution branch to which the load will be directly connected. One contactor shall control the normal supply, the other the standby supply they shall be electrically and mechanically interlocked so that they cannot both be closed at the same time.
- 25.2.3 On the failure of the normal supply, the unit shall operate in the following manner: -
 - a. After a delay, adjustable from 0 to 5 seconds (to avoid operation by a transient dip in voltage) a signal shall be given to start the prime rated generating set.
 - b. On receipt of a signal from the Mains KPLC line that it is ready to take the load and providing that the failure of the normal supply still persists, the normal supply contactors shall open and the standby contactor shall close. If the normal supply has been restored before the changeover has taken place the contactors shall not operate and the starting relay contacts shall open to initiate the shutting down of the standby generating set.
 - c. When the standby supply is in operation and the normal supply is restored and remains within 10% of rated voltage on all phases for a pre-set time (adjustable up to 30 seconds) the standby contactor shall open and the normal supply contactor shall close; the starting

relay contacts shall then open to shut down the generating set.

d. Provision shall be made so that automatic return to normal supply can be prevented if required.

e. Once a start signal has been sent to the generating set the engine starting sequence shall be allowed to continue until the set is ready to take the load before a stopping signal is sent.

25.2.4 By the additional external connections the following facilities shall be available: -

a. Remote starting of the standby generating set and transfer of the load to it

b. Restoration of the normal supply on failure of the standby generating set

c. Each switch shall be labelled with its duty and each position shall be marked. The following switches shall be provided and fitted:

1. A Contactor Control Switch with make before break contacts and 'Hand and 'Auto' positions. In the 'Hand' position the unit shall be controlled by the 'Contactor Hand Control Switch (Section 23.9 (2)). In the 'Auto' position the unit shall operate automatically irrespective of the position of the 'Contactor Hand Control Switch'.

2. 'Contactor Hand Control Switch' with 'Standby and "Normal' position. This switch shall enable either contactor to be closed when the 'Contactor Control Switch' is in the "hand' position.

3. Contactor By-Pass Switches shall be provided to enable the essential load circuits to be served direct from the normal supply to enable the generator and/or the control equipment to be serviced. The by-pass switches shall be provided with a suitable and conspicuous label warning against leaving the generator in the disconnected position.

d. Indicating lamps or illuminated panels shall be provided on the front of the panel. They shall be appropriately labelled, easily visible and shall give the following information;

'Normal Supply Available'

'Standby Supply Available'

'Normal Supply in Use'

'Standby Supply in Use'

e. A push button labelled 'Test' Shall be provided to enable a failure of normal supply to be simulated. If the button is pressed and released the equipment shall complete the starting sequence, and when the set is ready to take load it shall be shut down. If the button is held depressed the equipment shall change over to the standby supply when the set is ready to take load.

- f. The control circuit supply will be either 12 volts D.C or 24 volts D.C. depending upon the starting battery and charger

26. LOCK OUT

26.1 The set shall stop and lock out to prevent further starting when:

- a. It fails to start when the electric starter motor has been in operation for 20 seconds under automatic start conditions
- b. The lubricating oil pressure falls to a value at which it would be unsafe to continue running the engine
- c. The coolant does not flow, where the engine is fitted with a visible flow indicator on the coolant system
- d. in coolant cooled engines the coolant temperature exceeds a predetermined limit
- e. in air cooled engines the cylinder head temperature exceeds a safe maximum
- f. The overspeed trip has operated

26.2 Failure of the circuits concerned shall not cause a set to shut down.

27. FAULT INDICATION

Each lock-out detailed in Section 26.1 shall be indicated by a lamp on the panel together with an indication of the fault causing the shut-down. The fault warning lights shall be set to operate before the lock-out

28. LOCK-OUT RESET

Reset of the lock-out shall be by hand

29. FIRE SERVICE TERMINALS

29.1 An emergency stop circuit shall be provided with terminals marked FA1 and FS2. These terminals shall be initially fitted with a link and are for optional connection to a remote fire switch. Opening of this circuit shall stop the set if it is running, and as long as the circuit remains open the set shall be incapable of being started by 'Hand' or 'Automatic' control. The circuit shall be self-resetting so that the set is available for automatic starting when the circuit is restored.

29.2 Terminals shall be provided in the battery circuit for optional connection to a fire service battery switch. Opening of this switch shall isolate the control circuits from their supply.

30. STARTING BATTERY AND CHARGER

30.1 The battery shall be either 12 or 24 volt and capable of withstanding the loads imposed upon it by its specified duties. It may be of lead-acid or alkaline type and shall be of sufficient capacity for four starts in succession once in an eight-hour period. Auxiliary circuits connected to the battery shall be protected by fuses.

30.2 The battery shall be used to supply any automatic starting and control equipment, and relay operation shall not be impaired when the battery is supplying current to the starter motor.

30.3 A single phase supply shall be provided for battery charging (trickle charger) from an external mains supply

30.4 A charger shall be provided which will recharge the battery after engine starting and maintain it in a charged condition when the set is standing or is in service. It shall also supply the load of any automatic starting and control equipment, and any additional load up to 24 volts level when the set is running and in service. An alternative quick charge rate shall be provided. The charger shall be fitted with an ammeter to measure the charge and discharge current excluding the starter motor current.

Schedule 1, as referenced in the technical evaluation document as information to tenderer

SCHEDULE 1 : INFORMATION TO THE TENDERER

Item	Minimum Requirements
1. Diesel Engine	
Make and type	See part 11.1
Stroke and bore	
Sound proof canopy	Weather proof roof and removable top and side panels accessible through panel keys only
Output KVA	(As per table 1), 415/240V, 3-phase ON SITE standby
Engine control module (ECM)	See detailed specifications in part 17, remote, manual, auto starting selection
Functional Requirements	Automatic start, stop and remote crank, see part 18.5
Fault indication and LOCKOUT	Each lock-out detailed in part 26.1 to part 28 a lamp on the panel together with an indication of the fault causing the shut-down. The fault warning lights shall be set to operate before the lock-out
Net continuous rating in HP a) At sea level b) On site	See Part refer to table 1, section 1 for specific altitude) HP output Maximum 4% for every 1000 feet altitude rise
Operating Conditions: Temperature range and relative humidity	Temp range of 50 ⁰ C – 400 ⁰ C, and Relative Humidity up to 100% Relative Humidity see part 7.1 – 7.5
Engine Speed	1500 rpm
Sound level	Not exceeding 80 dB (A) at 1-6 meter span
Silencer and exhaust	See part 11.14
Daily service tank level indicator	Gauge with dial provided
Set arrangement	See part 10 and Attach floor layout diagram and provide three dimensional drawings
2. Water cooling :-	Engine coupled cooling Fan see part 15.1 – 15.1.4

Quantity of Water required	Coolant/water as per part 15
Coolant	Cooling system Coolant/ Water as per part 15
Detail of the coolant circuit	See part 15 and Provide drawings and mark in the brochure/manual
Radiator; Make and type	Engine mounted
Aspiration	Part 11.9, Natural/ Forced Induction
Quantity of air required	As per part 11.9
3. Auxiliaries	
Filters	See Part 11.5 plus KS 06-294: 1986, Grade 'A' and Grade 'B' suitable for use in a dusty atmosphere shall be fitted on the engine air intake
Coolers	See part 15.2
Primary pumps	
Tachometer and drive	See part 13.1
Speed Governor	Per part 11.2 & 11.6
Running hours meter	Digital on the ECM
4. Safety devices:-	As per Part 26
High temperature	
Over speed trip	
Low pressure (lubricating oil)	
Cooling water flow trip	
Speed sensing devices	
Lubricating oil thermometers:- Number Position	Thermocouple type or approved equivalent One each fitted at the inlet and outlet of the engine oil cooler
Coolant thermometer:- Position Starting battery Charger	Radiator entry and output a 12v or 24 v-volt battery supply with charger as per Specifications number 30
5. Lubrication Recommends (s) Lubricating oil circuits	As per part 11.1 & 11.3
Alternator	See part 16, 3 -phase, 415V, brushless with rectifier excitation
6. Alternator and Exciter cooling Quantity of cooling air required	Make and type Bearings Insulation (B.S. 2757) Coolant/Air as per part 14
7. Electrical Control Panel Automatic voltage regulator: Make and type	As described in Part 19, 20 & 21
Where mounted (if not on panel)	Inside the Control Panel
Control circuits and wiring diagrams and	Provide schematic drawings and wiring plans as per

schematics	part 44
Relays:- Make and type	Relays type Main output Circuit Breaker: make and type Meters: make and type, Method of delayed operation
8. Automatic start and stop Changeover Operation Unit Dimensions: Type and control Type of mounting Contactor: make and type Relays: make and type Fuses: make and type	As per part 25.2 - Indicators - mains failure - by-pass switch and - Status displays
9. Performance Data Fuel Consumption L/hr	As per 45.2 : Performance or FIELD TESTING (main areas of focus)
10. Generator Set Full length mm, Width mm, FOR ALL generators	Not exceeding (l*w) 4000*1500
Drawings and Pictorials	As laid down in part 44; Engine and Building drawings, as comments to issued drawings and schematics

SCHEDULE 2

INFORMATION TO BE SUPPLIED BY THE TENDERER, in response to Technical evaluation Q1.

Item	Specify Details and indicate/mark on the brochure/manual	Evaluators' comments
1. Diesel Engine		
Make and type	Make.... Type.....	
Stroke and bore (mm)	Stroke.... Bore..... No. of Cylinder....	
Sound proof canopy		
Output KVA ●kVAkVA	

<ul style="list-style-type: none"> ● 415V AC ● 3-Phase ● 50Hz at 1500rpm 		
Engine control module ECM	Make..... Model/Type.....	
Sound level (Not exceeding 80 dB (A) at 1-6 meter span)		
Aspiration		
Natural Aspirated or Forced Induction		
Quantity of air required		
Alternator		
Brushless Alternator coupled directly to the diesel engine	Make;..... Model.....	
2. Automatic start and stop Changeover Operation (programmable) Yes/No		
3. Generator Set Full length mm, Width mm ALL generators	Length mm Width (depth) mm	

31. CABLES AND CABLE HANDLING MATERIALS (as specified in the specific facility BoQ)

32. WIRING

Power cables and small wiring cables interconnecting major components shall be of the heat and oil resistant type and shall be metal sheathed or run in metal ducts or metal conduit, which shall be coded and terminated with lugs or eyes or to be soldered, the terminations shall be clearly marked with the numbers and letters of the terminals to which they are connected. Terminals shall be numbered or lettered, easily accessible and fitted with individual insulating barriers or adequately spaced. Barriers shall be fitted to separate control terminals from power wiring terminals.

33. EARTHING AND EARTH BONDING

All metal work housing electrical equipment shall be bonded on a brass-earthing terminal of not less than ISO bolt M10.

34. CONTACTORS

Contactors shall have circuits designed for A.C. or D.C. operation and shall be rated in accordance with BS 775 / KS 04-182: 1982. Four-pole contactors shall be fitted for three-phase equipment and two-pole contactors for single-phase equipment. Main and auxiliary contacts shall be silver faced or better.

35. RELAYS

35.1 Relays shall preferably be of the sealed type mounted in approved plug-in based with

spring loaded retainers but if this is not practicable they shall be mounted on individual sub-bases and wired so that easy access is obtained to soldered connections. Unsealed relays shall be enclosed in individual or common dust protecting cases.

35.2 Time delays, if of the pneumatic type, shall operate on filtered air. The thermal type of time delay relay will not be accepted.

36. FUSES

Fuses shall comply with BS 8, category of duty AC 46, fusing factor class A1 (Fuses shall comply with KS-183:1978). A spare fuse cartridge for each pole shall be mounted inside each equipment.

37. RECTIFIERS AND CAPACITORS

37.1 Rectifiers and capacitors shall be suitable for any transient voltages likely to be uncounted during the operation of the equipment and for the internal operating temperature of the enclosures at the specified maximum external ambient temperature.

37.2 Electrolytic capacitors will not be accepted.

38. ENCLOSURES FOR ELECTRICAL AND CONTROL EQUIPMENT

Enclosure for electrical and control equipment shall be drip proof and dust protecting, with adequate front and rear access as necessary for maintenance and repair. Special attention shall be given to the method of construction and to the mounting of the components to minimize the effect of vibration. Diagrams of connections in durable form shall be mounted inside the enclosures.

39. GUARDING

All live and moving parts shall be adequately guarded to prevent injury to personnel.

40. INFORMATION PLATES

A non-ferrous metal rating plate shall be fixed on the front of the alternator control panel door, giving the following information: -

Continuous and standby output rating	KVA at 0.8 p.f
Voltage	- V - phase – wire
Rated current	Amps
Frequency	Hz, engine speed rev/min
Control supply	Year of manufacturer

41. DANGER PLATES

Since this set is automatically started a reversible plate 400 x 250mm shall be fixed by screws in a prominent position of each side of the set. One side of the plate shall be blank and painted at the same colour as the set; the other side of each plate shall be signal red (BS 2660, colour 0-6000 with the following inscription in white:

DANGER

THIS MACHINE IS AUTOMATICALLY CONTROLLED DO NOT WORK ON IT
UNTIL STARTING EQUIPMENT ISOLATED OR DISCONNECTED AND CAUTION
NOTICES ARE DISPLAYED

42. TROPICALISATION OF COMPONENTS

All components shall be fully trivialized and protected against mould growth.

43. FINISH

43.1 All ferrous metal works shall be either painted or processed to give a rust proof coating. Ferrous metal work to be painted shall first to be either shot blasted or thoroughly wire brushed to remove all scale and oxide and immediately given one brushed coat or two sprayed coats of primer. After not less than four hours, one brushed or two sprayed undercoats followed by one brushed or two sprayed finishing coats of heat and oil resisting quality paint shall be applied.

43.2 Successive coats of paint shall be of slightly differing shades. Interior surfaces of electrical equipment enclosures shall be finished white and all external surfaces shall be finished grey (BS 2660, colour 9-097).

43.3 Engine crank cases shall not be painted internally unless the paint is resistant to the lubricating oil.

44. MAINTENANCE MANUAL

44.1 Upon Practical completion of the Works the Supplier shall furnish to the Engineer four copies of a Maintenance Manual relating to the installation forming part of all of the works.

44.2 The manual shall contain full operating and maintenance instructions for each item of equipment, plant and apparatus as set out in a form dealing systematically with each system. It shall include as may be applicable to the Contract Works the following and any other items listed in the text of the Specification hereinafter.

44.2.1 System Description

44.2.2 Plant

44.2.3 Valve Operation

44.2.4 Switch Operation

44.2.5 Procedure of Fault Finding

44.2.6 Emergency Procedure

44.2.7 Lubrication Requirements

44.2.8 Maintenance and Servicing Periods and procedures

44.2.9 Colour Coding Legend for all Services

44.2.10 Schematic and Wiring Diagrams of Plant, Apparatus and Switchgear

44.2.11 Record Drawings (as installed), True to Scale, reduced to International A4 size

44.2.12 Lists of Primary and Secondary Spares

44.3 The Manual is to be specially prepared for the Contract Works, and Manufacturers' standards descriptive literature and plant operating instruction cards will not be accepted.

44.4 Manuals shall be printed on good quality paper preferably international A4 size and shall have stiff covers of durable material. The maker's name and the rating of the set shall appear on the front covers. The soft copy version of the manuals shall also be provided.

45. AS BUILT DRAWINGS AND DOCUMENTATION

Within one month of the date of completion the Supplier shall provide 3 prints of all drawings showing the installations "As built" and a soft copy.

- 1) Where indicated, a building drawing showing details of cable entries, pipe entries and ducts required, and the exhaust system.
- 2) A general arrangement drawing showing the principal dimension and weight of the set
- 3) A general arrangement of the diesel engine
- 4) A general arrangement of the alternator and exciter showing terminal markings, polarity, and phase rotation.
- 5) A general arrangement of the electrical control panel(s).
- 6) A schematic and wiring diagram of the electrical control panel(s)
- 7) Genset user manual, service and maintenance manual including schematics and wiring diagrams (in English).

46. WORK TESTS

46.1 The set shall be tested as a unit at the manufacturers works (or elsewhere by agreement) for output and performance generally in accordance with the requirements of BS 649 and BS 2613. The Engineer shall be given adequate notice in writing of the date and time of the works tests and he or his representative shall be present at such tests and be given all reasonable facilities for his own inspections during the course of the tests.

46.2 Performance or FIELD TESTING (main areas of focus)

After the assembly the unit shall be tested in the presence of the client. The following tests shall be conducted on the engine and alternator.

- i. Full load test for at least 8 hours
- ii. Over loading test on engine as per standards
- iii. Fuel & Oil consumption checks
- iv. Determining efficiency.
- v. Insulation (megger) resistance test on alternator
- vi. Checking regulation of speed and voltage as well as frequency on certain load variations.
- vii. Testing of control wiring.
- viii. Any other tests as may be required to satisfy the Owner/Electrical inspectorate of the performance of the Unit.

46.3 Whether or not the Engineer or his representative attends the tests, he shall be furnished by the Supplier with copies of all relevant test certificates.

47. COMMISSIONING

47.1 The Supplier shall include for fully commissioning the set and its control equipment and for the purpose of the required tests, shall provide all necessary instruments, tools, fuel and lubricating oil.

47.2 The following tests and checks as applicable shall be carried out by the Supplier in the presence of the Electrical Engineer and Mechanical engineer or his representative.

47.3 Check that the main frame is level in all directions.

Engine and generator shafts are in proper alignment and the vibration absorbing devices are properly installed and located.

47.4 Check coolant and sump oil levels and that the coolant jacket and radiator heaters (if fitted) are in working order

47.5 Check the battery's state of charge indicator on top of the battery

- ensure the battery top is clean, dry, free of dirt and grime
- inspect the terminals, screws, clamp and cable for breakages, damage or loose connections
- apply thin coating of high temperature grease to ports and cable connectors for added protection
- inspect the battery case of any signs of physical damage or warpage (these are symptoms of overcharging or overheating)
- ensure the state of battery is always FULLY charged.

48.6 Examine the containers in which the fuel and lubricating oils were delivered and check that the types and grades of oils are a recommended for the units

48.7 Check that all radiator and engine block coolant drain points are free from sludge and other blockages.

48.8 Check engine bolts, main drive couplings, valve clearances, fuel plump settings, governor settings, pipeline connections, water hose, exhaust couplings, flexible pipework etc., and where a separate coolant tank is fitted, that the coolant level is satisfactory.

48.9 Check all outgoing connections on the generator and at the control panel. All lugs for principal connections shall have clean and bright contact surfaces. A suitable abrasive material shall be used where necessary.

48.10 Check access panels and doors for proper opening and closing and for the functioning

of any interlocks fitted.

48.11 With the set isolated from the main supply and the selector switch in the 'manual' position, start the engine by means of the 'start' push button and allow it to run up to normal speed. Check that during the time the engine starter motor is in operation, the mains battery charger is automatically switched off to avoid its being overloaded by the reduction in voltage across the battery. Where a battery charging dynamo is fitted. Check that the main battery charger is disconnected by the operation of the auxiliary Sub-Contactor during the time the engine is running.

48.12 Check instruments and gauges for normal operation and response and that the generator voltage is being maintained within the prescribed limits, making due allowance for no load conditions. Compare the reading of the frequency meter with that of the engine tachometer, where both are fitted.

48.13 Stop engine by turning selector switch to 'off position and verify that generator contactor opens at between 95% and 85% of normal voltage. Re-check coolant and oil levels.

48.14 Turn selector switch 'to auto' position. Disconnect the sensing circuit supply and check that the set starts, the mains contactor opens, and the generator contactor closes in correct order. Reconnect the sensing circuit to verify that the Engine stops on the restoration of the mains supply and the contactor s operate correctly

48.15 Check voltage sensing and time delays on each phase in turn and also that the push buttons for mains failure simulation and Engine stopping operate correctly. NOTE: Running of the engine for any length of time under no-load conditions is undesirable and tests calling for such operation should be carried out in as short a time as possible consistent with thoroughness.

48.16 Operate the necessary isolators and switched to put the set on standby for the essential services network with the selector switch in the 'Auto' position, and using the mains failure simulation push, verify that the set operates correctly with the appropriate time delay for taking up load and that the carrying of the load and its distribution over the three phases are satisfactory.

48.17 Run the set at various loads for periods totalling at least 30 minutes. Check the voltage and current in each phase in turn and that the voltage and frequency are being maintained within the required limits with large alterations of loads

48.18 Check the operation of the turbo-charger unit (if fitted) and the colour of the exhaust gas at various loads.

48.19 Check that the various engine safeguards operate satisfactorily.

48.20 Check the vibration absorbing devices for proper operation and that the performance of all flexible connections both mechanical and electrical, are satisfactory.

48.21 When all tests are satisfactory and agreed with the Engineer or his representative, the lubricating oil and coolant levels shall be finally checked, the fuel oil tank replenished, and the set left in normal operating order.

48.22 An initial supply of all lubricating oils and greases shall be provided by the Supplier.

48.23 Additional lubricating oil shall be provided for recharging the engine sump once together with a supply of lubricating oils and greases to cover the normal use and servicing of the set during the 24 months maintenance period (warranty period).

48.24 SPARE PARTS

The Supplier shall submit with his tender a separate priced list of spare parts, including any optional extras which he recommends should be purchased for the set and its control equipment and which are not supplied as standard with the unit.

48.25 TOOLS

A complete set of tools and general and special testing equipment shall be provided, including grease and oil guns, necessary for the normal maintenance of the generator set and its controls.

The tools shall be of the best quality, the spanners being of chrome vanadium steel and shall be contained in suitable robust steel toolbox with lid fitted with a lock and two keys. All tools and testing equipment may be used by the Supplier in the execution of the Contract works but will not be accepted as part of the Contract works unless they are handed over in clean and undamaged condition, in perfect working order and effectively in new condition.

49. MAINTENANCE

49.1 The Supplier shall maintain the complete set and associated control equipment forming the unit for a period of twenty-four (24) of calendar months from the date that the unit is put into commission and regular use.

49.2 During the maintenance period, the Supplier shall at his own expense: -

49.2.1 Make good any defects in the unit and replace any parts that fail or show signs of weakness or undue wear in consequence of faulty design, workmanship or materials on notification of the defect.

49.2.2 Visit the site and with all diligence attend to any such defect that arises within 48 hours of receiving notification of the defect.

49.2.3 Carry out regular examination and servicing of the unit at the intervals laid down by the manufacturer or every three months, whichever is the sooner; the service examination to include all necessary adjustments, greasing, oiling, cleaning changing of lubricating oils to keep the unit in sound and efficient working order.

49.2.4 Provide maintenance log book at Contractors cost and shall be filled every time there is breakdown by the personnel solving default and

49.3 If during the maintenance period the unit is or is likely to be out of use for a period greater than 48 hours, due to the unit or part thereof developing a defect attributable to faulty design, workmanship or materials or due to neglect of maintenance by the Supplier, the Supplier shall at his own expense immediately provide and install on free loan a suitable temporary unit for use until the required repair or replacement has been satisfactorily undertaken and the original set (or its replacement) put into proper working order.

49.4 At the end of the twenty four (24) months period of maintenance the Supplier shall (in addition of the normal servicing work) carry out a comprehensive examination and test of the set and its auxiliaries, including the checking of the operation of controls and safeguards, to ensure that the unit is in proper working order and in satisfactory condition for handing over to the client whose representative shall be present at such examination and test.

50. INSTALLATION OF CABLES

50.1 General

Bending of cables shall be in accordance with table 52c of the IEE Regulations and no cable shall be bent to radius less than that specified by the cable manufacturers.

Cables shall be rated for the maximum connected load with due consideration to the following factors:

- (i) Voltage drop not in excess of 4% of the nominal voltage.
- (ii) Ambient temperature.
- (iii) Degree of excess-current protection.
- (iv) Grouping.
- (v) Cables run under defined conditions.

50.2 Cables in conduits and Trunking

All cables shall be polyvinyl chloride (PVC) insulated to BS 6604, "PVC-insulated cables (non-armoured) for electric power lighting", 450/750-volt grade, unless an alternative is specified elsewhere in the contract documents. The quality and size of cables contained in any one conduit shall comply with IEE Regulation 529-7 and Appendix 12.

No cable with a cross-section area of less than 1.5mm² shall be used. All cables installed in a conduit or trunking system shall be PVC single insulated conductors and shall be colour coded in accordance with the IEE Regulation 524-3 and Table 52A.

Final sub-circuits shall be run in conduits separate from main or sub-main cables. All cables in conduit shall be drawn in simultaneously. All cables shall be drawn in without the use of excessive force, Without the use of lubricants and the wiring shall be easily withdrawable.

50.3 PVC/SWA/PVC Cable

These cables shall comprise copper conductors unless specifically detailed otherwise, laid up with PVC fillers bedded with an extruded inner PVC sheath, armoured with a single layer of galvanized steel wires, aluminium or strip as specified, and covered overall with PVC sheath.

Cables shall be manufactured to BS 6346 "PVC insulated cables for electrical supply" with conductor dimensions and resistances in accordance with BS 6360 1969, "copper conductors in insulated cables and cords", Armouring shall be galvanised steel to BS 1442.

Attention is drawn to Chapter 52 of the IEE Regulations and Appendix 9. Where the armour wires of cables are used to provide protective conductor, they shall comply with the requirements of Chapter 54 of the IEE Regulations, particularly section 543; alternatively, additional cables with copper conductors shall be installed to reduce the impedance to a level which ensures compliance with Section 543 of the IEE Regulations.

The PVC/SWA/PVC cables should be terminated in the cable manufacture's approved glands. These shall be of the compression type providing controlled radial compression of the sheath seal. The gland shall incorporate an armour clamping ring and earthing ring and, where used outdoors, a lead washer shall be used to ensure a watertight joint between the gland and the unit to which it is fitted. The earthing ring shall be rigidly fixed to the item of equipment and terminated using brass nuts, bolts and washers. All gland terminations shall be protected by a PVC shroud which shall fit tightly over the cables.

The electrical Supplier is responsible for determining the true nature and extent of cable routes. No claim on the grounds of lack of knowledge will be entertained. All cable routes shall be agreed with the Engineer. Cable joints shall be avoided especially for the main cables. In the event that they are unavoidable then proper connections or splices shall be used subject to engineer's approval. After the cables have been installed and terminated, but prior to putting into service, they shall be subjected to an insulation test of 500 volts and the results of these tests (recorded on test sheets) forwarded to the Engineer.

51. CONDUIT AND CONDUIT FACILITIES - MILD STEEL CONDUIT SYSTEM

51.1 Conduits

Conduits shall be installed as required by the IEE Regulations and as detailed in this specification.

All metal conduits must be heavy gauge, seam welded, steel tube screwed conduits manufactured to BS 31, "steel tube screwed conduits and fittings for electrical wiring", Class B, BS 4568, "Steel conduit and fittings with thread of ISO form for electrical installation", for metric conduit, unless specified otherwise. Conduits shall be finished black stove enamelled, except in positions exposed to water (other than water used in construction), steam condensation or the action of weather, where hot galvanised conduits shall be used.

Any conduits work rejected by the Engineer shall be replaced at no extra cost. No conduit smaller than 20 mm in diameter or longer than 50mm diameter shall be used.

All bends in conduit shall be in accordance with the IEE Regulation 529-5, and made in a conduit bending machine fitted with a former of the correct radius for each conduit size.

Conduits shall be secured in an efficient pipe vice whilst being screwed. Conduit system shall be installed so as to ensure compliance with requirements of IEE Regulations 529-7. Attention is drawn to Appendix 12 of the IEE Regulations.

51.2 Conduit Fittings

Conduit fittings shall have same finish as the conduits being used and shall comply with BS 31 or BS 4586. All conduit fittings shall be screwed or loop-in malleable iron circular type, fitted with covers secured by brass screws. Rectangular adaptable steel boxes may be used on multi-conduit runs.

All circular type boxes must be fitted with long screwed spout conduit entries with the screwed thread terminating within the spout and the edges of the internal orifice of the box rounded and smoothed to act as a bush except for the adaptable steel rectangular boxes and loop-in conduit boxes, in which case male bush and coupling must be used for conduit connections. In concealed installation, boxes shall be fixed with the rims flush with the finished surface, but when, for any reason whatsoever, the rims are below the surface, suitable extension rings of the required depth shall be provided and installed to finish flush with the surrounding surfaces and with the lids of sufficient oversize (7.5 mm minimum all round) to cover the junction between box and plaster. In no case will the use of site-manufactured bends, sets, elbows, inspection elbows or tees be permitted.

51.3 Fixing of Conduits

All conduits must be firmly and rigidly fixed to be entirely without whip or movement. Space-bar saddles, or strap saddles, must be used on the timbers in roof spaces and will be allowed when the conduits are run on the underside of exposed unsealed floor or ceiling joints. Pipe hooks or crumpets will not be allowed except for security conduits in chases, or screeds, when the top of the hook must at least be 10 mm below the finished surface of the wall, or 25 mm below the floor finish. Pipe hooks shall be galvanised.

The finish of the saddles must in all cases conform to the finish of the supported conduits. Galvanised, sherardised or cadmium plated screws shall be used in all cases where galvanised conduits are installed.

The standard cast iron distance saddle, (single fixing base and two-screw fixing top), must be used for all conduits run on the surface of walls and ceilings etc., fixed at intervals of not more than 1.2 metres.

51.4 Conduit Runs and Concealment

The routes of the conduit installation shall be agreed with the Engineer prior to commencing the installation. Conduits shall be installed at least 150 mm from, and preferably under, any hot water pipes and at least 50 mm from other surface pipes and cables. Conduits shall be bonded to other surfaces in accordance with the requirements of IEE Regulations 413-2 and 547-4 to 547-7 inclusive.

Each continuity test shall be applied to the system before plastering, screeding, or casting of concrete is commenced. Surface work will be allowed where certain pre-fabricated methods of construction preclude the concealment of the runs, and or fair-faced brickwork or block work or other unplastered walls.

Conduit runs shall be planned to obviate the need for draw-in boxes, but where the use of such boxes is unavoidable they shall be accessible at all times and be fitted with covers. When Conduits are specified as being installed on the surface the runs must be arranged to render the whole system as neat and inconspicuous as possible, having regard to the existing architectural features. All vertical and horizontal runs must be taken where conduits converge and run together near distribution centres to obtain a symmetrical layout. The distance between the conduits shall be maintained through bends and sets and shall not vary noticeably.

51.5 Flexible Metallic Conduit

Flexible Conduit shall comply with the BS 731 part 1. "Flexible steel conduit and adaptors for the protection of electrical cables." It shall be used for the final connection from a rigid conduit installation to the terminal boxes of all the equipment provided with a means of positional adjustment and /or where vibration may reasonably be expected to occur.

Flexible conduits shall be PVC sheathed and shall be terminated using approved glands. In all instances a separate PVC insulated green and yellow coloured protective conductor complying with table 41A1 or 41A2 and section 543 of the IEE Regulations shall be installed, terminating at each end into purpose-made earthing terminals.

Under no circumstances will flexible conduits be accepted in lieu of sets and bends in a rigid conduit installation.

In normal circumstances flexible conduits shall have a minimum length of 300 mm and a maximum unstretched length of 800mm. It shall permit a full range of withdrawal, adjustment or movement of the equipment.

51.6 Locking, Bushing and Coupling

All conduit ends must be filed square and reamed before erection to ensure freedom from internal burrs and roughness.

Running couplings shall only be used on black enamelled steel conduit installations, and the use of this shall be kept to the minimum. All running couplings shall be secured by means of the lock nuts or lock rings, and the exposed thread painted after installation.

Every conduit connection to the equipment, boxes, distribution boards, loop-in boxes, cable trunking etc, shall be made by means of a screw coupling and a male hexagonal headed smooth bore brass bush. The smooth bore shall be fitted to secure the conduit to the item connected via a purpose-made clear hole to be closed by the bush and coupling when fitted. Paint must be removed from the surface of the item connected to allow it to be covered by the end of the coupling which shall be filed, clean and square, to ensure a good mechanical and electrical metal to metal joint. Any exposed area of metal from which paint has been removed must be

made good in a matching paint. Bushes shall be fitted and tightened by means of correctly fitting spanners. Mutilated bushes damaged whilst being fitted must be removed and replaced. Conduits connecting via couplings shall be connected by a means of 15 mm long threaded section and shall have a gap of approximately 2 mm between them. No thread shall be exposed except running couplings.

51.7 Continuity and Earthing

The whole of the conduit installations shall be mechanically and electrically sound and continuous throughout their length in accordance with the IEE Regulations.

Where the conduit system is used to provide a protective conductor it shall comply with the requirements of Chapter 54 of the IEE Regulations particularly Section 543; alternatively, a separate protective conductor shall be installed in the conduit to comply with Section 543 of the IEE regulations.

52. CABLE TRUNKING-SHEET STEEL

Trunking shall only be installed in situations which will remain readily accessible throughout the life of the buildings. No cable trunking shall be installed behind a plastered ceiling or in other inaccessible situations.

All cable trunking shall comply with BS 4678, part 1 "Steel surface trunking" and part 2 for "Steel underfloor (duct) trunking".

Sheet steel cable trunking may be used on installations employing steel conduits, for connecting two or more switchboards together or where several conduits would otherwise have to run alongside each other. Proper allowance should be made for the derating of cables installed together in a container system. The cables must be capable of carrying the current imposed by the equipment connected. Attention is drawn to Chapter 52 of the IEE Regulations, particularly Section 522, and Appendix 9: the current carrying capabilities of cables indicated shall not be exceeded. The Engineer must be consulted as to precise details concerning trunking routes and applications.

All lengths of trunking shall be heavy gauge zinc coated steel connected together by internally fitted rectangular couplings of sufficient width to provide a minimum bearing face of 25mm, to which the lengths shall be bolted on site or welded at the factory.

Adequate provision shall be made to allow for expansion.

All Tee pieces and bends shall be formed with similar means of connection and the inner radii area shall be such that cables will not be bent through a radius less than that prescribed in the IEE Regulations. Only bends and tees of approved pattern will be accepted. All fixing screws within the trunking shall be of the round head type. The trunking shall have an overlapping well-fitted lid securely fixed to the trunking by approved means that will avoid damage to the cables. Self-tapping screws shall not be used.

All necessary accessories including long sleeve couplings, end piece, bends, sets, tees, reducers, branches, fillets, pinracks, cable retainers etc., shall be purpose-made units rather than being fabricated on site.

Where a change in direction of trunking run occurs, the deviation should be effected by a purpose-made unit manufactured on similar lines to the bends and tee pieces described above. Where this is not practical, changes in direction shall be fabricated in a neat workmanlike manner. All joints shall fit closely and gaps will not be permitted. All burrs and sharp edges shall be removed and no screw shall protrude into the trunking.

Trunking shall be firmly attached to its associated equipment either by bolted flanges or by male bushes and couplings.

Where trunking is connected to equipment by means of flange connectors, the entry into the equipment shall be of the same cross-section as the trunking.

Where trunking does not terminate in equipment, the otherwise open end shall be capped with a cover suitable bolted in position.

Where communications, extra low voltage circuits (category 1) etc., are contained in a trunking, the requisite number of separate compartments shall be provided to segregate the wiring. Where conduits are taken off such trunking they shall not pass through other compartments unless prior permission is obtained from the Engineer.

The entire trunking is required to be recessed in the structure of the building, the finished edge of the trunking is to be installed flush with the plasterwork.

Trunking runs shall be so arranged that the lid or cover plate is always on the top or side and not underneath, unless this cannot be avoided, in which case the Engineer's permission shall be obtained.

Wherever trunking passes through walls, vertical partitions etc., a fixed piece of trunking lid shall be fitted to the trunking extended 25 mm either side of the wall or other barrier, this is to allow removal of the adjacent lid without disturbing the building fabric. Care shall be taken to ensure that no opening is left between the trunking and the building structure through which fire might spread. In addition a suitable barrier of incombustible material shall be provide and fitted inside the trunking, in accordance with the IEE Regulations 528-1. On vertical runs of trunking internal incombustible barriers shall be fitted at the distance between floors or 5m, whichever is the less, in accordance with IEE Regulations 523-6.

All necessary trunking support work, hangers, brackets and fixing requirements shall be provided by the electrical Supplier.

Earth links of the appropriate size and type shall be installed at every jointing coupling, manufactured bend, etc., throughout the entire trunking system. Where trunking is used to provide a protective conductor it shall comply with the requirements of Chapter 54 of the IEE Regulations, particularly Section 543; alternatively, a separate protective conductor shall be installed in the trunking to comply with section 543 of the IEE Regulations. In cases where

sheet steel trunking is installed and there is danger of movement, a flexible earth conductor shall be installed bonding all joints in the trunking. This shall be fitted in addition to the standard earth links. Cable retaining strips shall be fitted at 1 m intervals. Insulated cable support pins shall be fitted at intervals of 4 m in vertical runs of trunking and at the top of the vertical trunking.

53. CABLE TRAYS

Cable trays shall be formed from perforated steel of not less than 0.9 mm thickness up to and including 100 mm width - 1.25 mm thickness from 150 mm up to and including 300 mm width - and 2.00 mm thickness above 300 mm width. They shall be galvanised unless otherwise specified. Tray shall be adequately sized to support the cable without bunching.

Support shall be by means of steel brackets installed at intervals necessary to provide a rigid fixing and ensure that no undue deflection occurs in the complete installation. The brackets shall be galvanised prior to fixing. Dome-headed bolts, nuts and washers of finish suitable to the tray shall be used between tray and brackets.

Fixing to the surfaces of walls, ceilings, etc. shall be by means of expansion-type masonry plugs or bolts. Fixings shall be galvanised unless otherwise stated. Cable trays shall be installed using factory-formed bends, elbows, tees, couplers and risers etc. Site fabrication of elbows etc., will only be permitted with prior approval of the Engineer and where it is not possible to obtain the necessary factory-made item.

Where cuts have been made, the tray shall be painted with zinc rich paint.

Holes which have been cut to allow cables to pass through shall be suitably bushed.

Suspension sets shall comprise threaded M12 cadmium plated hanger rods together with nuts and locking washers, vertical hanger brackets, support channel, tray hold-down clips etc., all of which shall have a galvanised finish.

All cables shall be securely fixed to traywork and the complete installation must be carried out in a neat and workmanlike manner without crossovers. A 25% reserve margin in size and weight shall be allowed for all cable tray works.

Cables of 30 mm diameter and above shall be fixed using the appropriate size cable straps of approved manufacture.

On light duty multi-cable runs, cable straps of plastic coated metal shall be used to secure cables.

Bunching of cables will not be permitted.

Cables shall be clipped by means of copper or brass saddles and clips where high temperature or humid conditions are likely to be experienced. In all cases, saddles, clips, straps, etc., shall be fixed to the tray by means of brass screws or bolts and nuts.

54. PROTECTION OF PVC/SWA/PVC CABLES

a. General

Cable routing shall be such that the maximum degree of protection against accidental damage is obtained by running cables along the inside of channels and beams, etc.

Cables shall be laid in performed trenches or duct throughout all paved areas. Ducts shall be installed for underground cables before the paving is constructed.

Cable ducts shall be sealed at both ends using materials which are resistant to any likely corrosive and insect attack in the area concerned.

All cables rising through floors and trench covers, except in switch rooms, shall be protected by a length of steel pipe which shall project at least 150 mm above the finished surface level.

The open end of the pipe shall be sealed with a suitable compound. Care must be taken that all phases of single core cables pass through the same protective steel duct.

b. Cables Direct in Ground

All excavation and backfilling of cable trenches will be carried out by the main Supplier unless otherwise specified, but the electrical Supplier shall in any case make sure that trenches are made to a depth as specified.

The electrical Supplier shall lay cables direct in the ground in the following manner:-

75 mm (3 inches) of dry fine sand shall be placed to form a bed for the cables. After cables have been laid they shall be covered with additional dry fine sand well punned over and around the cables to a level of 75 mm above the top of the uppermost cable. Mechanical punners shall not be used for this work. The electrical Supplier shall supply and install concrete cable tiles which shall be carefully placed over the cable forming each circuit.

Until all the cables have been laid in the trench and have been covered with their protective tiles, no sharp metal tools such as spades or fencing stakes, shall be used in the trench. Rollers used during laying of cables shall have no sharp projecting parts liable to damage the cables.

c. Cables above Ground

For main cable runs the cable shall be run on approved tray or ladder rack, and secured to it at intervals of not more than 400 mm horizontally and 600 mm vertically.

Cables shall be dressed together and fixed with a common saddle. If the number of cables is such as to require the tiering of cables, the number of tiers shall generally be two.

55. TERMINATION OF CABLES

Cables shall be terminated in accordance with Chapter 52 of the IEE Regulations, particularly Section

Cables shall be terminated by one of the following methods: -

- (i) The cable conductors shall be sweated into lugs of the appropriate size for the cable and equipment terminal.
- (ii) The cable conductors shall be secured by compression type lugs of the correct size for the cable and equipment terminal.
- (iii) The cable conductors shall be secured in pinch screw terminals.
- (iv) The cable shall be secured by means of clamps.

Where cables are required to terminate at connectors, as at lighting points, such connectors shall secure all the strands of stranded cables. Care shall be taken to ensure that cables are not damaged during preparation for termination.

Cables terminating at pinch screw terminals shall be twisted together and single cables shall have the conductor doubled back to ensure adequate purchase for pinching screws.

Cables connected to lamp holders or other components at which heat is produced shall be insulated with heat resisting material capable of withstanding, without detriment, the temperature encountered.

All terminations on PVC/SWA/PVC insulated cables shall be by compression type glands of an approved design and manufacture with facilities for clamping the armouring the outer sheath of the cable.

Glands mounted outdoors shall incorporate a seal to prevent ingress of moisture into the gland, and all glands shall be fitted with a thermoplastic shroud.

Where circular terminations are to be made, these shall be completed using Ross Counterney terminals.

Where cables are terminated in "Klippon" type terminals with parallel faced jaws, the individual cores shall be terminated using the appropriate flat or hook blade crimped lugs. Where the terminal faces are concaved, the cores shall be terminated in wires pin crimped lugs.

The electrical Supplier shall avoid multiple connections under one screw or one pin. Where more than two wires are required, a common termination jumper bar shall be used.

Terminals shall be mounted on rails or supports. All internal wiring is to be clearly marked by markers.

56. SEGREGATION OF SERVICES

Cables of differing voltages shall be segregated so that there is no possibility of a fault in a power cable damaging any adjacent cables or imposing a different voltage upon them.

57. IDENTIFICATION OF CABLES

All cables shall be fitted with non-corrosive cable identification bands at each end, and at all changes of direction where they leave a group of cables. All cables cores connected to

equipment having marked terminals shall be fitted with non-corrosive identification bands bearing markings corresponding to those of the terminals at both ends.

58. EARTHING

The whole of the metallic portion of the installation, other than current carrying parts, shall be electrically and mechanically bonded to the consumer's main earth terminal and also if applicable, to the lighting protection system or other points specified.

The installation shall be earthed in accordance with the Sixteenth Edition of the Regulations for Electrical Installation issued by the IEE, BS CP1013, "Earthing" and BS 6651' "The protection of structures against Lightning". The electrical Supplier's attention is drawn to Chapter 54 of the IEE Regulations.

A main earth terminal shall be supplied and installed adjacent to the electricity supply cable termination. The terminal shall be of ample size and capacity to suit the installation. All items of equipment, switchgear, etc., shall be bonded to this earth terminal using PVC insulated PVC sheathed cables, coloured green and yellow and sized in accordance with Tables 41A1 of the IEE Regulations. An inworn label reading "**SAFETY ELECTRICAL CONNECTION - DO NOT REMOVE**" in engraved upper-case characters not less than 4.75mm high, shall be permanently fixed immediately adjacent to or on the earth terminal.

A heavy-duty copper clamp complying with BS. 951 shall be used to bond the main protective conductor to the electricity supply cable armouring or metallic sheath (where applicable the armouring and sheath shall be bonded together).

All protective conductors shall, where possible, be enclosed within metal trunking or conduit serving switchgear, distribution board etc., so as to provide mechanical protection. Where protective conductors are run on building surfaces they shall be properly fixed and supported by means of PVC coated metal saddles along selected routes.

Earth continuity between separate items of switchgear, distribution boards etc., mounted adjacent to one another shall be affected by means of high conductivity continuous copper tape, or PVC sheathed cable, coloured green and yellow, and sized in accordance with the Table 41A1 or 41A2 and Section 543 of the IEE Regulations, connecting all items to the earth terminal.

All items of switchgear, accessories, luminaries, conduits, and the outer sheaths of MICS cables, the armouring of all PVC/SWA/PVC cables together with all other items of electrical plant and equipment shall be effectively earthed by means of a protective conductor in accordance with Table 41A1 and 41A2 and section 543 of the IEE Regulations.

At every terminal point on the fixed wiring an integral earth terminal shall be provide e.g. BESA boxes, accessory boxes etc. A protective conductor shall be provided and installed between this terminal and the earth terminal on the associated switch, socket outlet, luminaire etc.

Each circuit protective conductor shall be connected to a multi-way earth terminal provided and fixed within each distribution board. The earth terminal shall be provided with an

adequate number of ways such that not more than one conductor per terminal shall be installed and the earthing conductors shall be connected in the same sequence as the current carrying conductors.

All metal piped services, e.g., Heating, Water and Gas Services, metal wastes and piped services at sinks, baths and showers etc., shall be bonded to the earth terminal in accordance with the IEE Regulations 413-2.

A 50mm section of each gas and water pipe, at position close to their entry into the relevant building, shall be cleaned and made smooth. A copper earthing clamp designed to permit the connection of protective conductors shall be provided and sized in accordance with Table 41A1 and 41A2 and Section 543 of the IEE Regulations.

The clamp shall be a proprietary type or shall be fabricated from high conductivity copper strip, minimum size 40 mm x 4 mm which shall encircle the cleaned sections of the pipe. A permanent label indelibly marked with the words, "**SAFETY ELECTRICAL CONNECTION - DO NOT REMOVE**" in legible type not less than 4.75 mm high, shall be permanently fixed at the points of connections.

The final connection of bonding conductors from gas, water pipes and other services to the earthing terminal shall not be completed until earth electrode and earth impedance tests have been satisfactorily completed.

Bonding connections to pipework shall be as unobstructive as possible where practicable shall be made in service ducts or accessible voids and shall be readily on the Record Drawings. All materials and sundry item shall be provided whether or not specifically mentioned, necessary to completely and effectively earth the installation. The installation shall be fully protected against dampness and corrosion and the effect of electrolytic action between dissimilar materials. A completely permanent installation shall be provided which shall be fully accessible for regular testing and inspection.

The value of earth resistance from any point of an installation to the general mass of earth shall be low enough to ensure operation of circuit protective devices and shall in any case not exceed four(4) ohms for electrical equipment, seven (7) ohms for lighting protection. Each earthing cable shall terminate in an approved design of cable lug.

Where earth conductors are run upon structures or walls they shall be fastened by means of heavy gauge non-ferrous fasteners not more than 0.75 m apart on horizontal runs and not more than 1.2 m apart on vertical runs and to give a minimum clearance of 4 mm from the fixing face.

In the event of the electrical Supplier not being able to establish a suitable earth connection to the electricity supply cable, earth electrodes shall be installed which shall be galvanised or copper clad steel extendable rods not less than 16 mm diameter and not less than 1.2 m in length. Connections to electrodes shall be made by means of solderless mechanical clamps.

To avoid corrosion, all earth system connections shall be cleaned bright and immediately covered with silicon MS4 compound or approved equal.

Earth pits, where required, shall be in accordance with the Supplier's relevant drawings, with the facility to disconnect the earth ring while measuring the electrode earth resistance.

59. LIGHTNING PROTECTION

Lighting protection shall be provided on high buildings/structures more than 10 m in height. such protection shall be effected by bonding each individual building/structures direct to the earthing system, in accordance with the BS CP 326, by a minimum size of 170mm² conductor.

60. CONTROL PANELS AND CUBICLES

The details specified in IEEE Regulations shall apply as far as fused switches, bus-bars and rating etc are concerned. The panels shall be constructed from rolled steel channel minimum size 60 mm x 30 mm deep x 5 mm or equivalent angle section clad with sheet steel of 3 mm gauge. 2 mm gauge may be used for covers and doors of not more than 1 m square.

Terminals shall be of the "Klippon" standards rail-mounted feed-through type or approved equal. All terminals shall be identified by means of numbered or lettered marking tags, which shall be identical to the number of letter applied to the cables. Cables shall be identified as terminations by means of cable markers as manufactured by "Klippon" or approved equal. 25% spare terminals capacity within wiring duct shall be provided. All components motors, starters, relays, timbers, etc. shall be labelled showing their reference and function and these shall relate to the panels' schematic wiring diagram provided with the "As-built" drawing and manuals.

All control panels shall be fitted with multi-pole isolating switches through which all electricity supplies shall pass. The door(s) of the control panel shall not open unless the isolating switch is in the "off" position. A facility to lock the control panel-isolating switch in the "off" position shall be included.

61. LABELLING AND ENGRAVING

61.1 Labelling

All fused-switch units, switch-fuses, switches, bus-bars chambers, distribution boards etc., and all items of equipment on the main panel shall be identified in accordance with section 514 of the IEE Regulations and shall have securely fitted externally a white 'Traffolyte', 'Formica' or other approved plastic laminate label engraved with 6 mm high black letters detailing the function of the equipment and any reference number.

Red, yellow, blue, plastic laminate phase discs shall be fixed inside all switchgear and distribution boards to indicate to which phase of the supply the various circuits are connected. The colourings shall comply with Part 524 of the IEE Regulations.

Each TP or TP & N item of switchgear shall have fitted on the cover a white plastic laminate label having 'CAUTION' - 415 VOLTS' engraved in 10 mm high red lettering.

61.2 Engraving

The electrical Supplier shall allow for engraving of all switched fused spurs, double pole switch accessories and any other accessories, which are customarily required.

The accessory plate shall be engraved in either black or red, capital letters 5 mm high, detailing and appliance or equipment being supplied by the accessory e.g., 'WATER PUMP' etc.

62. MOUNTING HEIGHTS

The approximate position of main switchgear, control equipment distribution boards, fittings and accessories shall be as indicated on the Drawings. Actual positions shall be determined on site by the Engineer.

Unless otherwise stated on the relevant drawings or directed by the Engineer the following mounting heights of all accessories above finished floor level shall be adhered to: -

Lighting Switches	1400 mm to centre
Socket Outlet and Spur	300 mm to centre (or 150 mm above work top level to centre)
Distribution Boards	1800 mm to lower edges.

All groups of accessories shall be in line either vertically or horizontally or as specified.

63. INSPECTION AND TESTING

A visual inspection shall be made in accordance with IEE Regulations 612-1. References shall be made to appendix 14 of the IEE Regulations, which is a checklist for initial inspection of installations.

The electrical installation shall be inspected and tested by the electrical Supplier in accordance with part 6 of the IEE Regulations.

Where any part of installation is to be concealed within a building, fabric tests shall be made to ensure that the installation is satisfactory prior to concealment.

Upon completion of the works the whole installation shall be subjected to the tests detailed hereafter and every defect shall be noted, corrected and brought to the notice of the Engineer.

All tests shall be witnessed by the Engineer to his full satisfaction and he shall be given at least one week's notice in writing of the proposed tests.

All labour and test instruments shall be provided by the electrical Supplier and the instruments shall be correctly calibrated and certified for the limits of accuracy required and shall be operated by competent person. If, in the Engineer's opinion, a particular instrument is not suitable, then an acceptable alternative shall be provided. The Engineer shall be at liberty to demand the use of any testing instrument or apparatus that he may reasonably consider to be necessary in the execution of the testing.

In the event of the installation failing to pass the test, the Engineer has the full authority of the Employer to deduct from the Contract Price all reasonable expenses incurred, due to him being required to attend a repetition of the test.

The following items, where relevant, shall be tested in the sequence indicated. Standard methods of testing, in respect of some of the following regulations of this section, are given in Appendix 15 of the IEE Regulations.

- i) Continuity of ring final circuit conductors.
- ii) Continuity of protective conductors, including main supplementary equipotential bonding.
- iii) Earth electrode resistance.
- iv) Insulation resistance.
- v) Insulation of site-built assemblies.
- vi) Protection of barriers or enclosures provided during erection.
- vii) Insulation of non-conducting floors and walls.
- viii) Polarity.
- ix) Earth fault loop impedance.
- x) Operation of residual current devices and fault voltage operated protected devices.

Upon completion of all tests and commissioning, two copies of detailed certificates shall be provided by the electrical Supplier to show that the equipment, materials, installation etc., have been tested and commissioned. One copy of each, duly completed and signed shall be submitted to the Engineer within 154 days of the results being obtained. The second copy of the certificates shall be retained to be included with operator and maintenance manuals.

The results of the test and details of completion for the electrical test shall be detailed on the Test and Completion Certificates respectively; issued by the National Inspection council for Electrical Installation Contracting or other approved authority.

(PLEASE PROVIDE THIS IN A DIFFERENT ENVELOPE)

PART B: FINANCIAL
(BILLS OF QUANTITIES)

(It should be noted that the information provided in this BOQ should be considered as approximate and indicative only. The bidder is required to fill each Bill of Quantity for each of the facilities and indicate the facility name on each BOQ document.)

LOT SUMMARY - LOT 2

S/No.	Facility/Site	Cost for Supply and Installation of Generators
1	Chemolingot Sub County Hospital	
2	Kabartonjo Sub County Hospital	
3	Kacheliba Sub County Hospital	
4	Lokitaung Sub County hospital	
5	Lokori Sub County Hospital	
TOTAL COST FOR ALL WORKS IN LOT 2 (Carried to FORM OF TENDER)		



PROPOSED GENERATOR SETS AND
ASSOCIATED WORKS

BILLS OF QUANTITIES

Bill of Quantities for the Generator Installations: Chemolingot**Last Updated: 10 February 2025**

Item	Description	Unit	Qty	Rate	Amount (KShs)
1	Supply, deliver to site, install, test and commission a 110 KVA* Sound-Attenuated, Powder coated galvanised steel) Standby-rated Generating set with, 415V/240V 3-phase, 1500 rpm, Max 77 dBA at 1 M. (*Site rating, to be achieved in Chemolingot, which is at 875m asl. Supplier to state actual sea-level rating)	1	No.		
2	Supply, deliver to site, install, test and commission daily service tanks	1	Item		
3	Supply, deliver to site, install, test and commission control panel(s), (complete with ov/uv relays)	1	Item	INCLUDE IN GENERATOR PRICE	
4	Supply, deliver to site, install, test and commission Automatic changeover contactor unit(s) (in Main switchboard)	1	Item		
5	Cost of tools as per Appendix No. 1	1	Item		
6	Cost of spares as per Appendix No. 2	1	Item		
7	Supply, deliver to site, install, test and commission Industrial silencer for the generator	1	No.		
8	Dia. 100mm, 3mm thick galvanized stainless steel tube exhaust system for generator complete with brackets and black industrial (gloss paint).	10	m		
9	4C 4mm ² PVC/SWA/PVC copper control cable, (Provisional)	10	m		
10	Cable glands for the above cable.	2	No.		
11	Cable lugs for the above cable, complete with Crimping.	8	No.		
Total C/F to Next Page					

Item	Description	Unit	Qty	Rate	Amount (KShs)
	Total B/F from Previous Page				
12	4C 50mm ² XLPE/SWA/PVC copper cable for the Generator (<i>provisional</i>)	10	m		
13	Cable glands for the above cable.	2	No.		
14	Cable lugs for the above cable, complete with Crimping.	8	No.		
15	Comprehensive protective multiple earthing of the generator in 1800mm long 16mm diameter pure electrolytic copper earth rod deep driven to permanent moisture level, copper clamp. 70mm ² green earth lead complete with all accessories. (Note: Use parallel rods if effective earthing cannot be achieved with 1 No. rod).	1	Item		
16	9 kg dry powder fire extinguisher complete with initial charge and mounting brackets	1	No.		
17	4.5 Kg carbon dioxide gas fire extinguisher complete with Pressure Gauge, initial charge and mounting brackets.	1	No.		
18	Any other items (to be detailed)	1	Item		
19	ATTENDANCE & LIAISON: Allow sum for attendance to other specialists, Contractors & Management team e.g. Electrical, Kenya Power, Client, etc.	1	Item		
20	DOCUMENTATION: Sum for Completion documents: Comprising Workshop drawings, manufacturer's technical product catalogues, users manuals, maintenance manuals, as installed drawings, test certificates, etc. { NOTE: Penultimate Valuation will not be paid until these are fully availed & signed off by the engineer }	1	Item		
21	TESTING & COMMISSIONING: Sum for Testing and commissioning of the entire installations Including activation and the necessary programing.	1	Item		
22	MINTENANCE AND SERVICING: Allow for periodic servicing during the warranty period (2 Years minimum) in accordance with manufacturer requirements	1	Item		
22	MINTENANCE AND SERVICING: Allow for periodic servicing during the warranty period (2 Years minimum) in accordance with manufacturer requirements	1	Item		
Total for Generator Sets and Associated Works					
Add 16% VAT					
Total for Generator Sets and Associated Works (incl VAT) Carried to Lot Summary Page					

Bill of Quantities for the Generator Installations: Kabartonjo**Last Updated: 10 February 2025**

Item	Description	Unit	Qty	Rate	Amount (KShs)
1	Supply, deliver to site, install, test and commission a 110 KVA* Sound-Attenuated, Powder coated galvanised steel) Standby-rated Generating set with, 415V/240V 3-phase, 1500 rpm, Max 77 dBA at 1 M. (*Site rating, to be achieved in Kabartonjo, which is at 2296m asl. Supplier to state actual sea-level rating)	1	No.		
2	Supply, deliver to site, install, test and commission daily service tanks	1	Item		
3	Supply, deliver to site, install, test and commission control panel(s), (complete with ov/uv relays)	1	Item	INCLUDE IN GENERATOR PRICE	
4	Supply, deliver to site, install, test and commission Automatic changeover contactor unit(s) (in Main switchboard)	1	Item		
5	Cost of tools as per Appendix No. 1	1	Item		
6	Cost of spares as per Appendix No. 2	1	Item		
7	Supply, deliver to site, install, test and commission Industrial silencer for the generator	1	No.		
8	Dia. 100mm, 3mm thick galvanized stainless steel tube exhaust system for generator complete with brackets and black industrial (gloss paint).	10	m		
9	4C 4mm ² PVC/SWA/PVC copper control cable, (Provisional)	10	m		
10	Cable glands for the above cable.	2	No.		
11	Cable lugs for the above cable, complete with Crimping.	8	No.		
Total C/F to Next Page					

Item	Description	Unit	Qty	Rate	Amount (KShs)
	Total B/F from Previous Page				
12	4C 50mm ² XLPE/SWA/PVC copper cable for the Generator (<i>provisional</i>)	10	m		
13	Cable glands for the above cable.	2	No.		
14	Cable lugs for the above cable, complete with Crimping.	8	No.		
15	Comprehensive protective multiple earthing of the generator in 1800mm long 16mm diameter pure electrolytic copper earth rod deep driven to permanent moisture level, copper clamp. 70mm ² green earth lead complete with all accessories. (Note: Use parallel rods if effective earthing cannot be achieved with 1 No. rod).	1	Item		
16	9 kg dry powder fire extinguisher complete with initial charge and mounting brackets	1	No.		
17	4.5 Kg carbon dioxide gas fire extinguisher complete with Pressure Gauge, initial charge and mounting brackets.	1	No.		
18	Any other items (to be detailed)	1	Item		
19	ATTENDANCE & LIAISON: Allow sum for attendance to other specialists, Contractors & Management team e.g. Electrical, Kenya Power, Client, etc.	1	Item		
20	DOCUMENTATION: Sum for Completion documents: Comprising Workshop drawings, manufacturer's technical product catalogues, users manuals, maintenance manuals, as installed drawings, test certificates, etc. { NOTE: Penultimate Valuation will not be paid until these are fully availed & signed off by the engineer }	1	Item		
21	TESTING & COMMISSIONING: Sum for Testing and commissioning of the entire installations Including activation and the necessary programming.	1	Item		
22	MINTENANCE AND SERVICING: Allow for periodic servicing during the warranty period (2 Years minimum) in accordance with manufacturer requirements	1	Item		
Total for Generator Sets and Associated Works					
Add 16% VAT					
Total for Generator Sets and Associated Works (incl VAT) Carried to Lot Summary Page					

Bill of Quantities for the Generator Installations: Lokitaung**Last Updated: 10 February 2025**

Item	Description	Unit	Qty	Rate	Amount (KShs)
1	Supply, deliver to site, install, test and commission a 110 KVA* Sound-Attenuated, Powder coated galvanised steel) Standby-rated Generating set with, 415V/240V 3-phase, 1500 rpm, Max 77 dBA at 1 M. (*Site rating, to be achieved in Lokitaung, which is at 800m asl. Supplier to state actual sea-level rating)	1	No.		
2	Supply, deliver to site, install, test and commission daily service tanks	1	Item		
3	Supply, deliver to site, install, test and commission control panel(s), (complete with ov/uv relays)	1	Item	INCLUDE IN GENERATOR PRICE	
4	Supply, deliver to site, install, test and commission Automatic changeover contactor unit(s) (in Main switchboard)	1	Item		
5	Cost of tools as per Appendix No. 1	1	Item		
6	Cost of spares as per Appendix No. 2	1	Item		
7	Supply, deliver to site, install, test and commission Industrial silencer for the generator	1	No.		
8	Dia. 100mm, 3mm thick galvanized stainless steel tube exhaust system for generator complete with brackets and black industrial (gloss paint).	10	m		
9	4C 4mm ² PVC/SWA/PVC copper control cable, (Provisional)	10	m		
10	Cable glands for the above cable.	2	No.		
11	Cable lugs for the above cable, complete with Crimping.	8	No.		
Total C/F to Next Page					

Item	Description	Unit	Qty	Rate	Amount (KShs)
	Total B/F from Previous Page				
12	4C 50mm ² XLPE/SWA/PVC copper cable for the Generator (<i>provisional</i>)	10	m		
13	Cable glands for the above cable.	2	No.		
14	Cable lugs for the above cable, complete with Crimping.	8	No.		
15	Comprehensive protective multiple earthing of the generator in 1800mm long 16mm diameter pure electrolytic copper earth rod deep driven to permanent moisture level, copper clamp. 70mm ² green earth lead complete with all accessories. (Note: Use parallel rods if effective earthing cannot be achieved with 1 No. rod).	1	Item		
16	9 kg dry powder fire extinguisher complete with initial charge and mounting brackets	1	No.		
17	4.5 Kg carbon dioxide gas fire extinguisher complete with Pressure Gauge, initial charge and mounting brackets.	1	No.		
18	Any other items (to be detailed)	1	Item		
19	ATTENDANCE & LIAISON: Allow sum for attendance to other specialists, Contractors & Management team e.g. Electrical, Kenya Power, Client, etc.	1	Item		
20	DOCUMENTATION: Sum for Completion documents: Comprising Workshop drawings, manufacturer's technical product catalogues, users manuals, maintenance manuals, as installed drawings, test certificates, etc. { NOTE: Penultimate Valuation will not be paid until these are fully availed & signed off by the engineer }	1	Item		
21	TESTING & COMMISSIONING: Sum for Testing and commissioning of the entire installations Including activation and the necessary programing.	1	Item		
22	MINTENANCE AND SERVICING: Allow for periodic servicing during the warranty period (2 Years minimum) in accordance with manufacturer requirements	1	Item		
Total for Generator Sets and Associated Works					
Add 16% VAT					
Total for Generator Sets and Associated Works (incl VAT) Carried to Lot Summary Page					

Bill of Quantities for the Generator Installations: Lokori**Last Updated: 10 February 2025**

Item	Description	Unit	Qty	Rate	Amount (KShs)
1	Supply, deliver to site, install, test and commission a 110 KVA* Sound-Attenuated, Powder coated galvanised steel) Standby-rated Generating set with, 415V/240V 3-phase, 1500 rpm, Max 77 dBA at 1 M. (*Site rating, to be achieved in Lokori, which is at 600m asl. Supplier to state actual sea-level rating)	1	No.		
2	Supply, deliver to site, install, test and commission daily service tanks	1	Item		
3	Supply, deliver to site, install, test and commission control panel(s), (complete with ov/uv relays)	1	Item	INCLUDE IN GENERATOR PRICE	
4	Supply, deliver to site, install, test and commission Automatic changeover contactor unit(s) (in Main switchboard)	1	Item		
5	Cost of tools as per Appendix No. 1	1	Item		
6	Cost of spares as per Appendix No. 2	1	Item		
7	Supply, deliver to site, install, test and commission Industrial silencer for the generator	1	No.		
8	Dia. 100mm, 3mm thick galvanized stainless steel tube exhaust system for generator complete with brackets and black industrial (gloss paint).	10	m		
9	4C 4mm ² PVC/SWA/PVC copper control cable, (Provisional)	10	m		
10	Cable glands for the above cable.	2	No.		
11	Cable lugs for the above cable, complete with Crimping.	8	No.		
Total C/F to Next Page					

Item	Description	Unit	Qty	Rate	Amount (KShs)
	Total B/F from Previous Page				
12	4C 50mm ² XLPE/SWA/PVC copper cable for the Generator (<i>provisional</i>)	10	m		
13	Cable glands for the above cable.	2	No.		
14	Cable lugs for the above cable, complete with Crimping.	8	No.		
15	Comprehensive protective multiple earthing of the generator in 1800mm long 16mm diameter pure electrolytic copper earth rod deep driven to permanent moisture level, copper clamp. 70mm ² green earth lead complete with all accessories. (Note: Use parallel rods if effective earthing cannot be achieved with 1 No. rod).	1	Item		
16	9 kg dry powder fire extinguisher complete with initial charge and mounting brackets	1	No.		
17	4.5 Kg carbon dioxide gas fire extinguisher complete with Pressure Gauge, initial charge and mounting brackets.	1	No.		
18	Any other items (to be detailed)	1	Item		
19	ATTENDANCE & LIAISON: Allow sum for attendance to other specialists, Contractors & Management team e.g. Electrical, Kenya Power, Client, etc.	1	Item		
20	DOCUMENTATION: Sum for Completion documents: Comprising Workshop drawings, manufacturer's technical product catalogues, users manuals, maintenance manuals, as installed drawings, test certificates, etc. { NOTE: Penultimate Valuation will not be paid until these are fully availed & signed off by the engineer }	1	Item		
21	TESTING & COMMISSIONING: Sum for Testing and commissioning of the entire installations Including activation and the necessary programing.	1	Item		
22	MINTENANCE AND SERVICING: Allow for periodic servicing during the warranty period (2 Years minimum) in accordance with manufacturer requirements	1	Item		
Total for Generator Sets and Associated Works					
Add 16% VAT					
Total for Generator Sets and Associated Works (incl VAT) Carried to Lot Summary Page					

Bill of Quantities for the Generator Installations: Kacheliba**Last Updated: 10 February 2025**

Item	Description	Unit	Qty	Rate	Amount (KShs)
1	Supply, deliver to site, install, test and commission a 110 KVA* Sound-Attenuated, Powder coated galvanised steel) Standby-rated Generating set with, 415V/240V 3-phase, 1500 rpm, Max 77 dBA at 1 M. (*Site rating, to be achieved in Kacheliba, which is at 1280m asl. Supplier to state actual sea-level rating)	1	No.		
2	Supply, deliver to site, install, test and commission daily service tanks	1	Item		
3	Supply, deliver to site, install, test and commission control panel(s), (complete with ov/uv relays)	1	Item	INCLUDE IN GENERATOR PRICE	
4	Supply, deliver to site, install, test and commission Automatic changeover contactor unit(s) (in Main switchboard)	1	Item		
5	Cost of tools as per Appendix No. 1	1	Item		
6	Cost of spares as per Appendix No. 2	1	Item		
7	Supply, deliver to site, install, test and commission Industrial silencer for the generator	1	No.		
8	Dia. 100mm, 3mm thick galvanized stainless steel tube exhaust system for generator complete with brackets and black industrial (gloss paint).	10	m		
9	4C 4mm ² PVC/SWA/PVC copper control cable, (Provisional)	10	m		
10	Cable glands for the above cable.	2	No.		
11	Cable lugs for the above cable, complete with Crimping.	8	No.		
Total C/F to Next Page					

Item	Description	Unit	Qty	Rate	Amount (KShs)
	Total B/F from Previous Page				
12	4C 50mm ² XLPE/SWA/PVC copper cable for the Generator (<i>provisional</i>)	10	m		
13	Cable glands for the above cable.	2	No.		
14	Cable lugs for the above cable, complete with Crimping.	8	No.		
15	Comprehensive protective multiple earthing of the generator in 1800mm long 16mm diameter pure electrolytic copper earth rod deep driven to permanent moisture level, copper clamp. 70mm ² green earth lead complete with all accessories. (Note: Use parallel rods if effective earthing cannot be achieved with 1 No. rod).	1	Item		
16	9 kg dry powder fire extinguisher complete with initial charge and mounting brackets	1	No.		
17	4.5 Kg carbon dioxide gas fire extinguisher complete with Pressure Gauge, initial charge and mounting brackets.	1	No.		
18	Any other items (to be detailed)	1	Item		
19	ATTENDANCE & LIAISON: Allow sum for attendance to other specialists, Contractors & Management team e.g. Electrical, Kenya Power, Client, etc.	1	Item		
20	DOCUMENTATION: Sum for Completion documents: Comprising Workshop drawings, manufacturer's technical product catalogues, users manuals, maintenance manuals, as installed drawings, test certificates, etc. { NOTE: Penultimate Valuation will not be paid until these are fully availed & signed off by the engineer }	1	Item		
21	TESTING & COMMISSIONING: Sum for Testing and commissioning of the entire installations Including activation and the necessary programing.	1	Item		
22	MINTENANCE AND SERVICING: Allow for periodic servicing during the warranty period (2 Years minimum) in accordance with manufacturer requirements	1	Item		
Total for Generator Sets and Associated Works					
Add 16% VAT					
Total for Generator Sets and Associated Works (incl VAT) Carried to Lot Summary Page					



SINGLE LINE DIAGRAMS

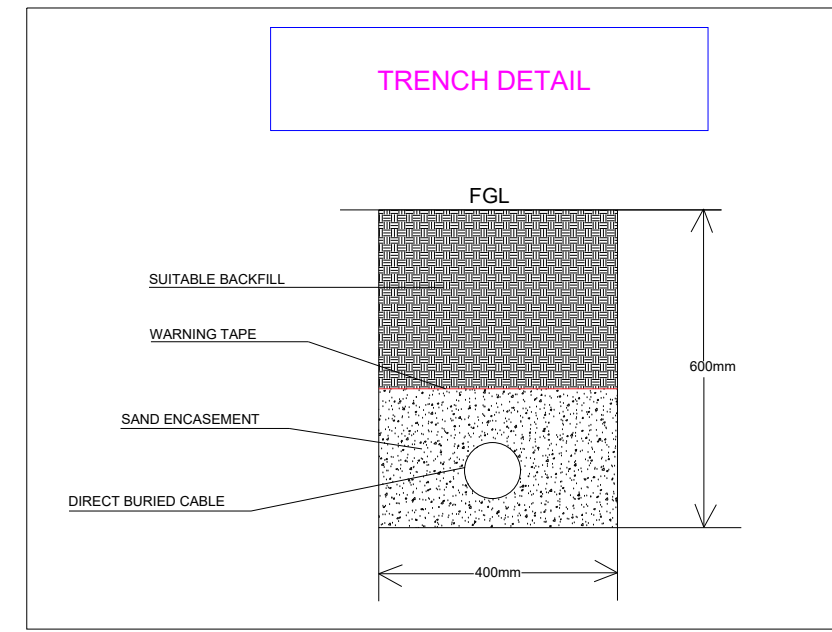

Section II

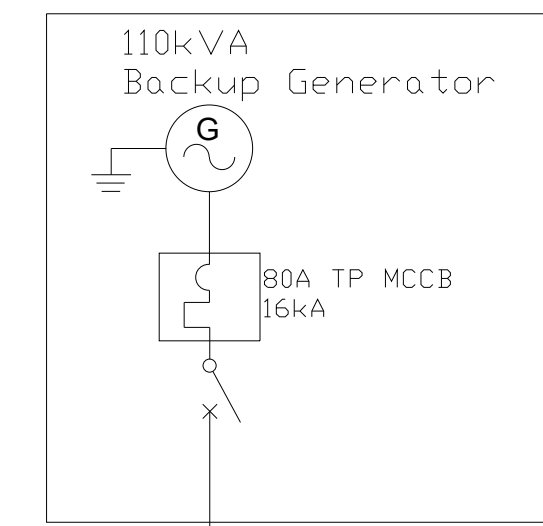

4C 50mm² + 25mm² XLPE/SWA/PVC
CU Cable
20m

Section I

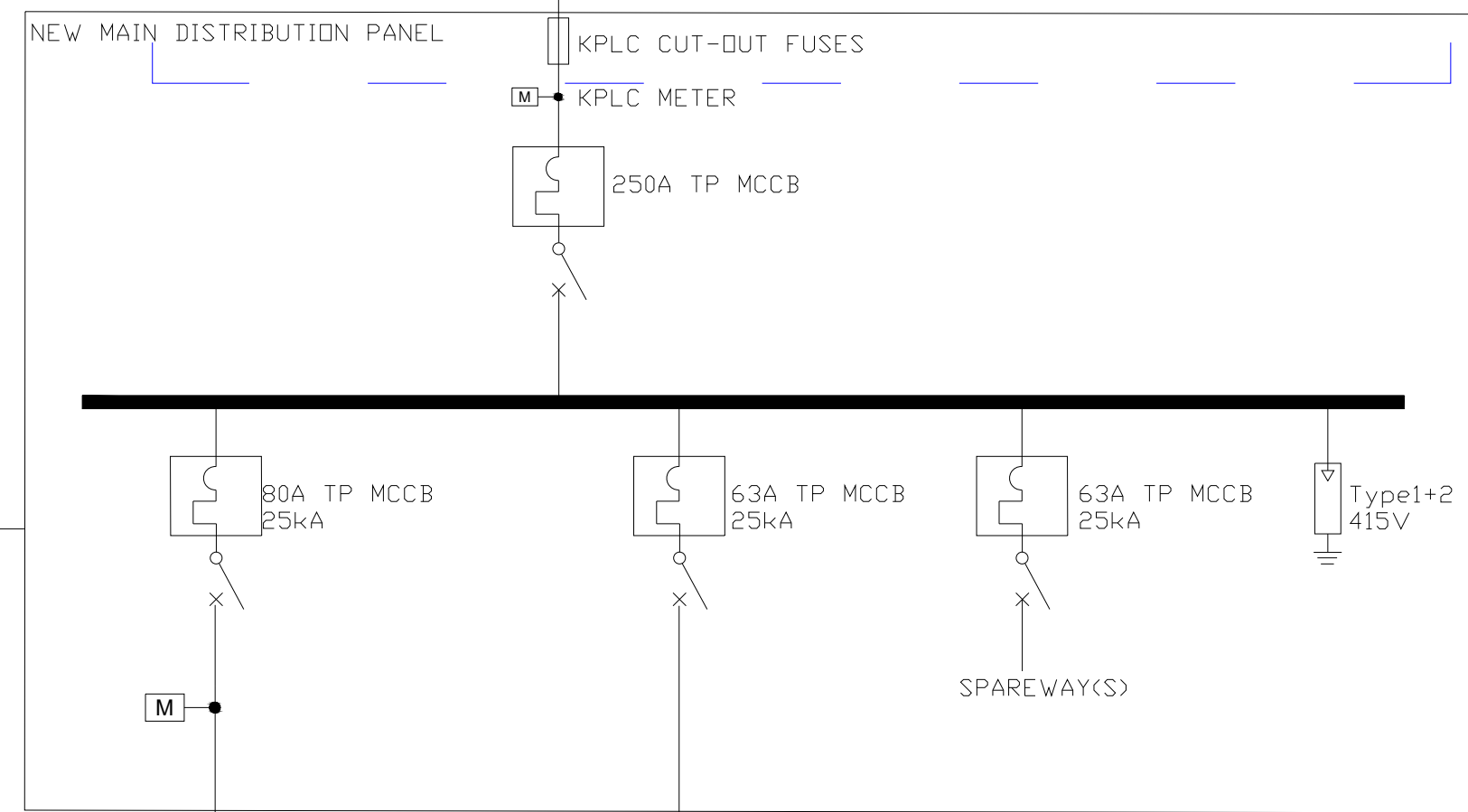
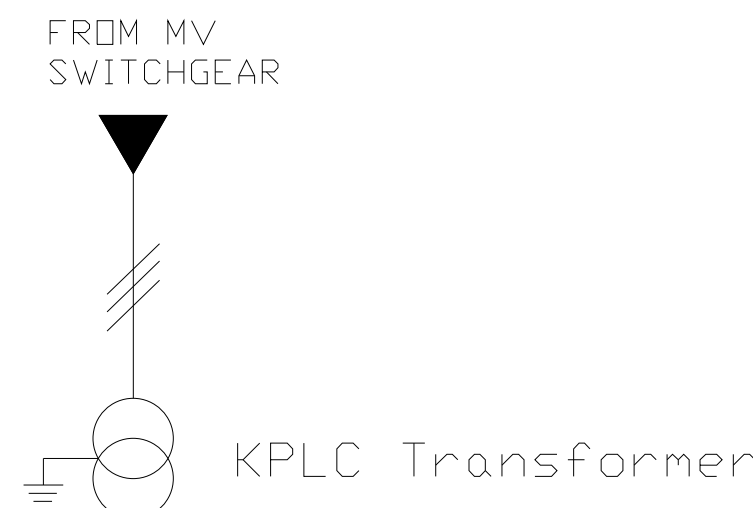

LEGEND:

	- Thermal-Magnetic Circuit Breaker		- Transformer
	- Residual Current Circuit Breaker		- Generator
	- Earthing		- Three-Phase Line or Cable
	- Surge Diverter		- Three-Phase Line or Cable, with Neutral and Earth
	- Mechanically and Electrically Interlocked Automatic Transfer Switch		- Single-Phase Line or Cable
	- Metering		- High Rupturing Capacity (HRC) Fuse
			- Utility Scope
			- Contractor's Scope
			- Existing Scope

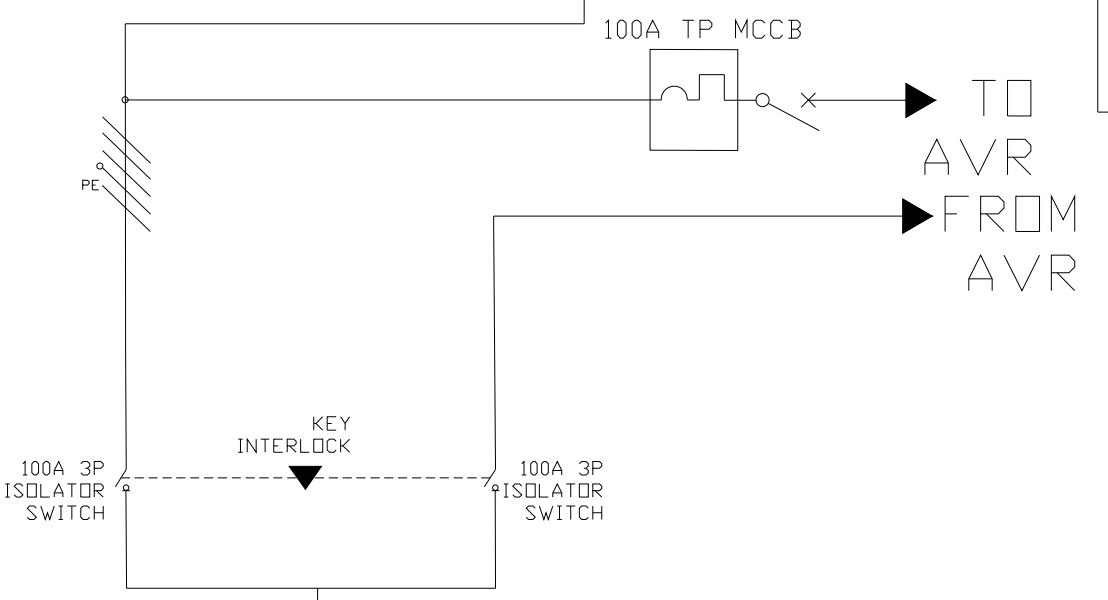

4C 25mm² + 16mm² XLPE/SWA/PVC
CU Cable
5m

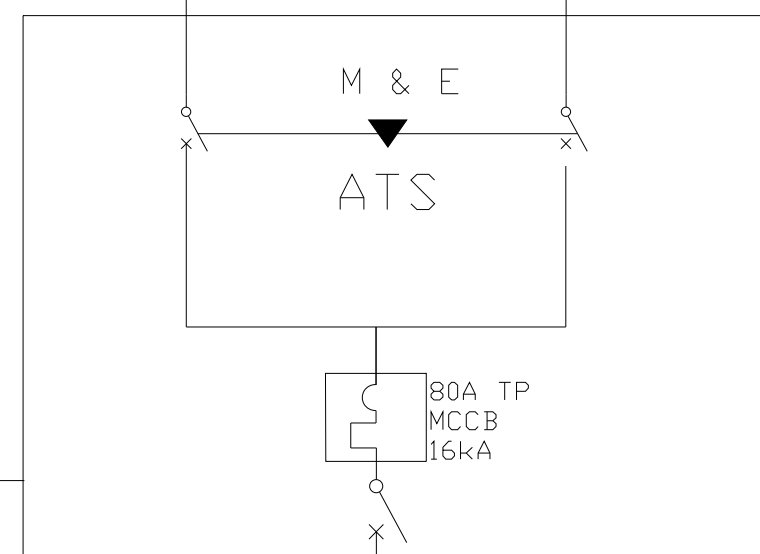

4C 50mm² + 25mm² XLPE/SWA/PVC CU Cable
75m

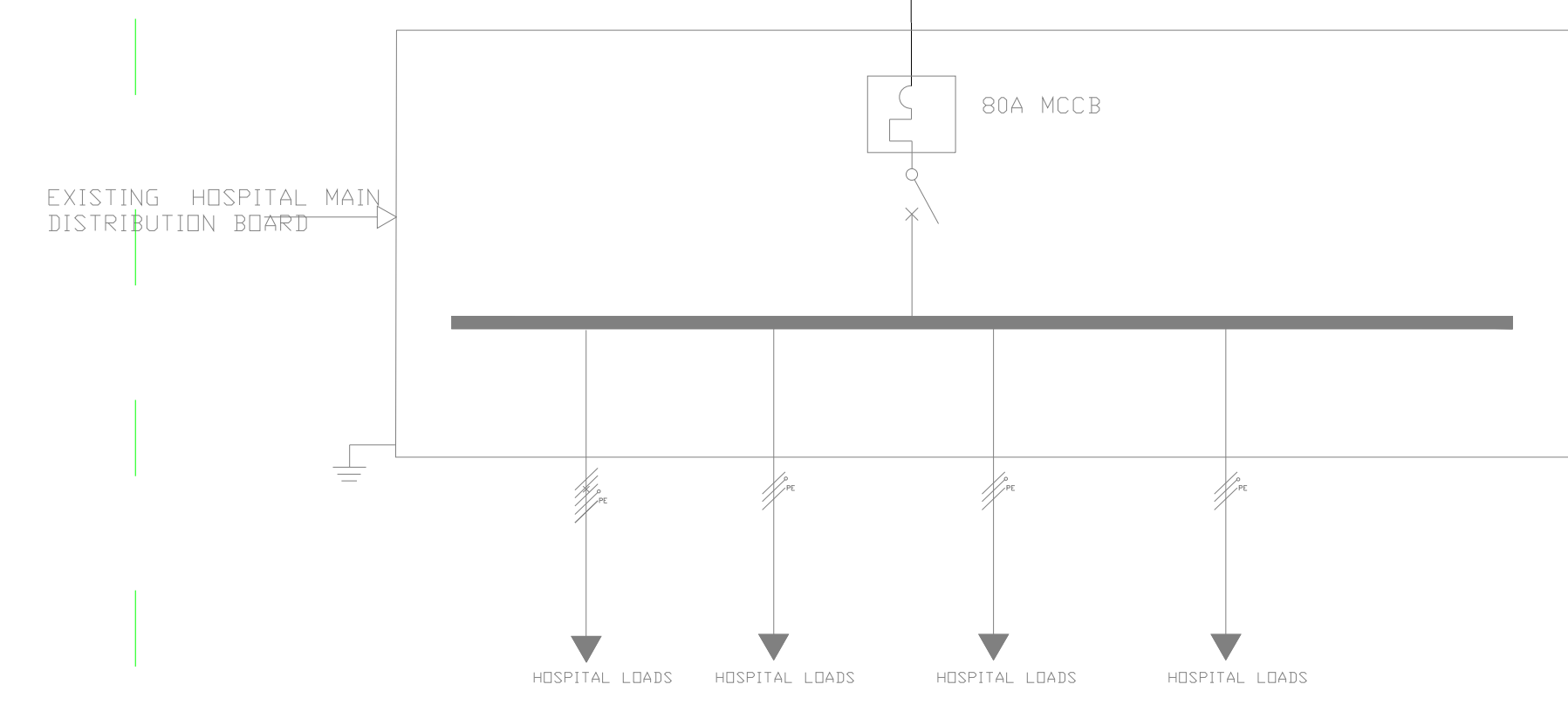
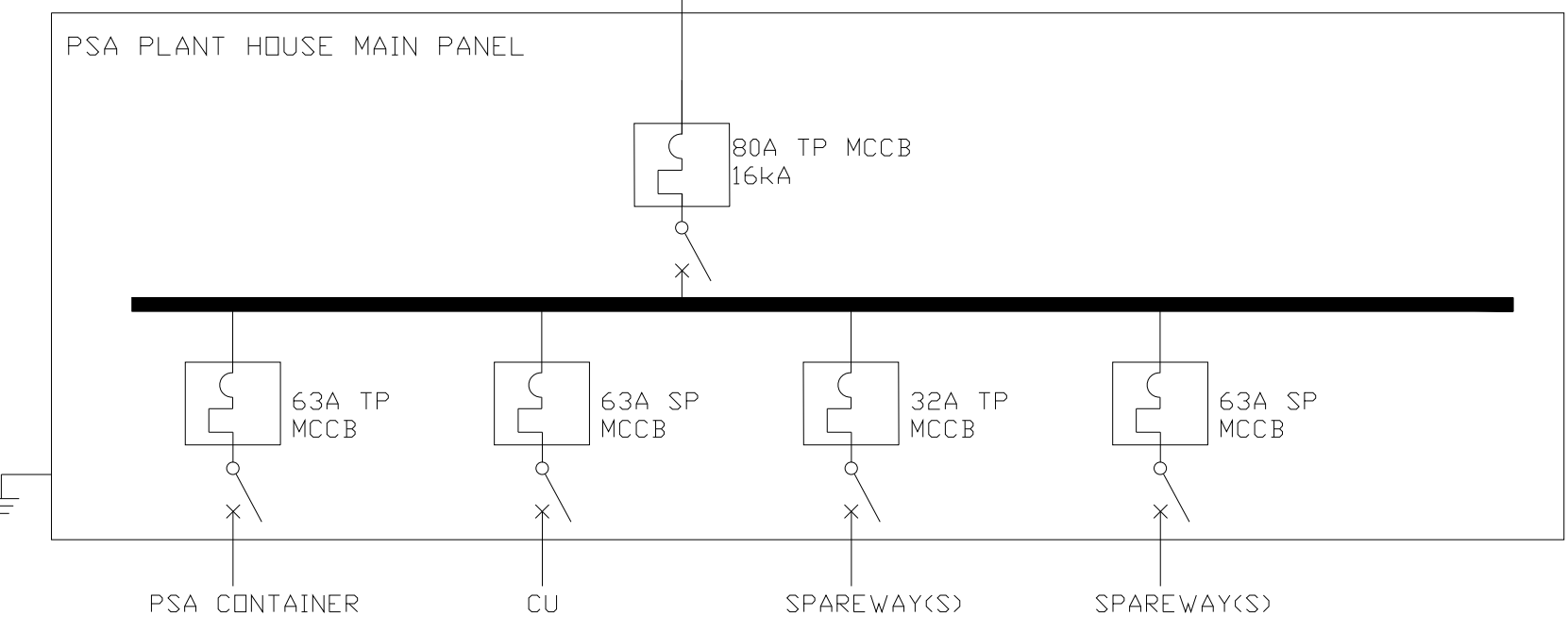

- NOTES:**
1. Coordinate with the Hospital, County Engineers and KPLC to ensure an adequately sized transformer is installed for current and medium term hospital power needs.
 2. Coordinate with Hospital and County Engineers to ensure the New Distribution Panel provisions are by and large in accordance with short to medium term Electrical Infrastructure works.
 3. Method of cable installation (I) is Armoured Cable buried underground in 600mm Deep trench.
 4. Scope of Work Under Blue (section I) is the responsibility of the utility Kenya Power and Lighting Company KPLC. Utility to provide quote and execute any upgrade works where necessary.
 5. Scope of Work Under Green (section II) encompass electrical works exclusive of Utility scope.
 6. PSA Plant load to primarily comprise a 30kW motor with Star-Delta Starter.
 7. Cable lengths are approximate. Exact lengths to be determined on site.

KEY PLAN	
The Global Fund	
OWNER	
Chemolingot PSA plant	
PROJECT	
SINGLE LINE DIAGRAM	
DRAWING TITLE	
DRAWING NUMBER	
SCALE	DATE 5/7/2024
JOB NUMBER	
DRAWN	CHECKED
Current Package	
E200	
DRAWING NUMBER	

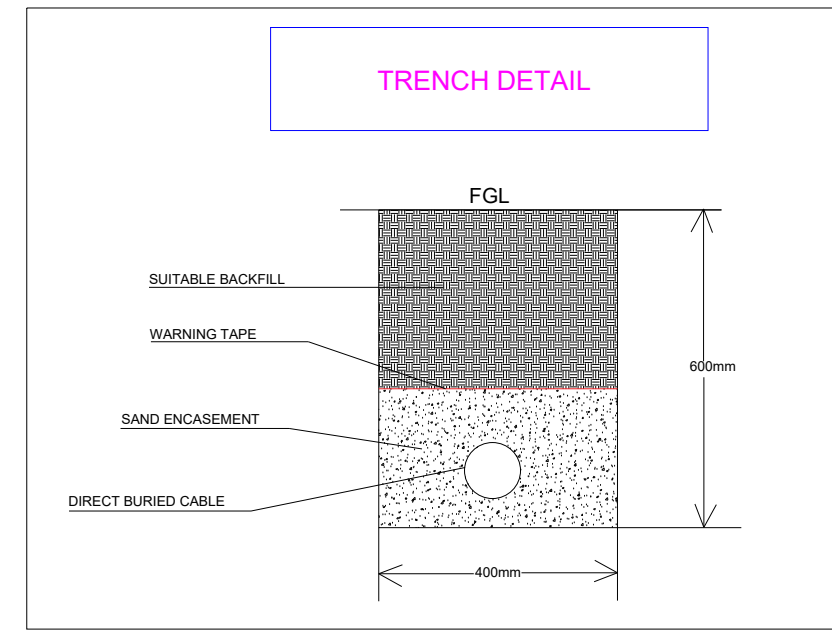

Section II

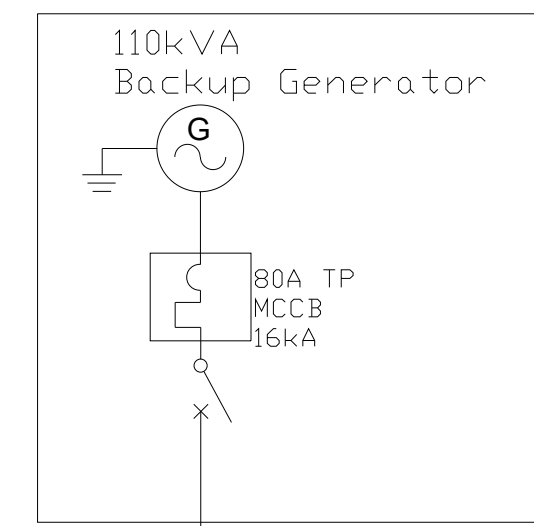

4C 50mm² + 25mm² XLPE/SWA/PVC
CU Cable
20m

Section I

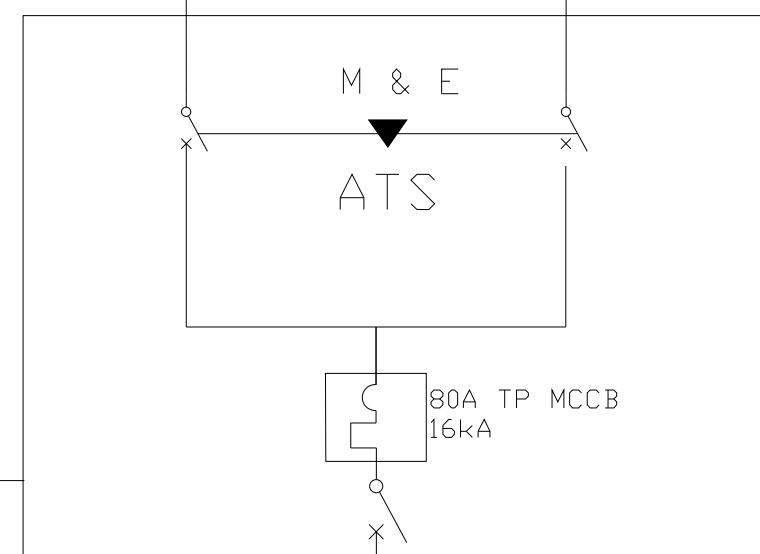
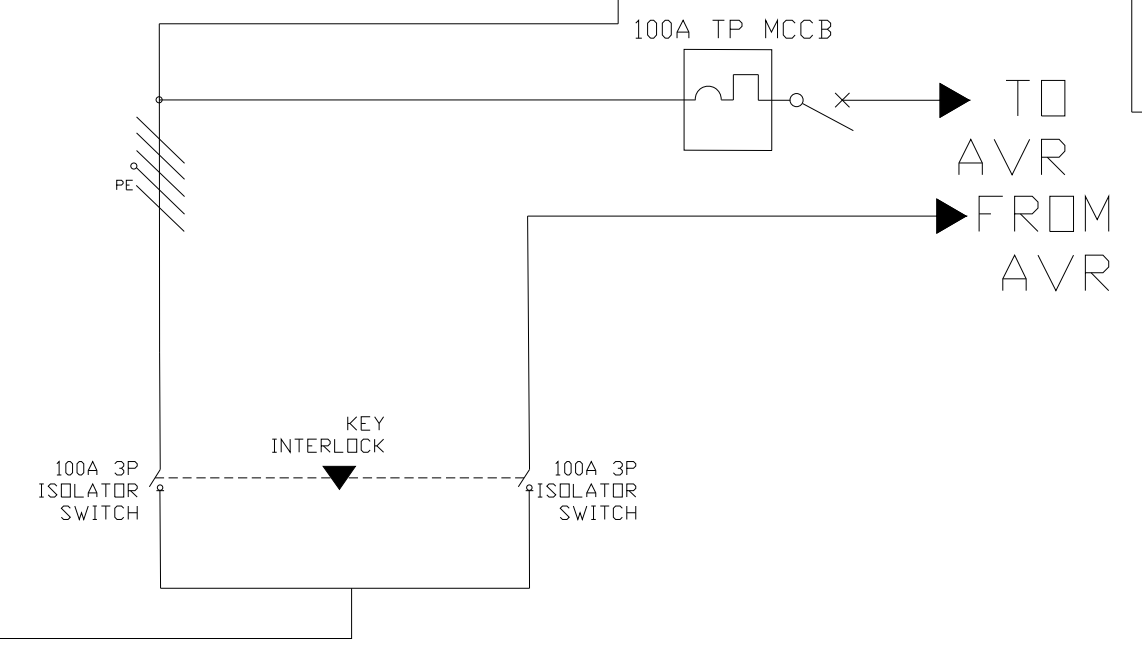
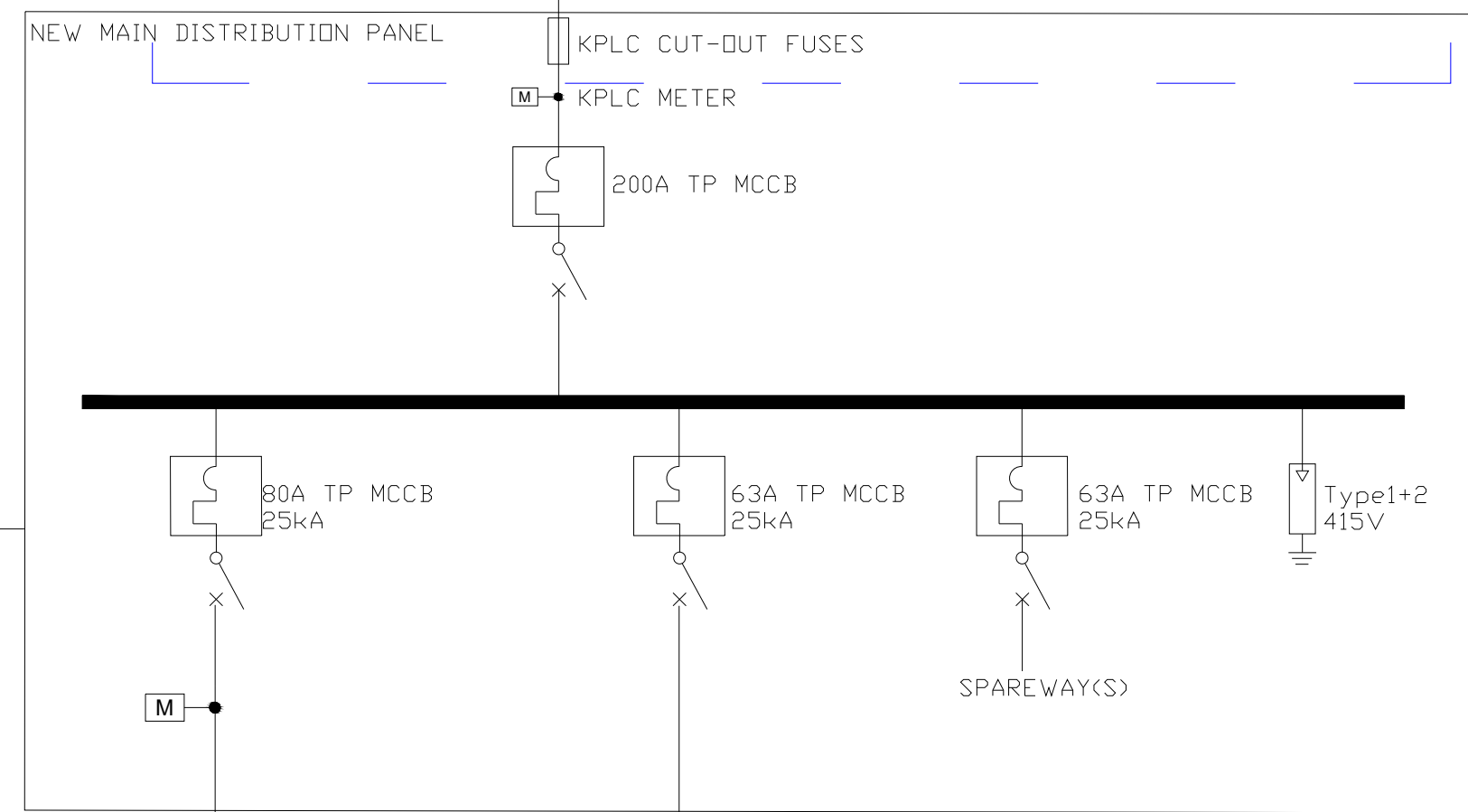
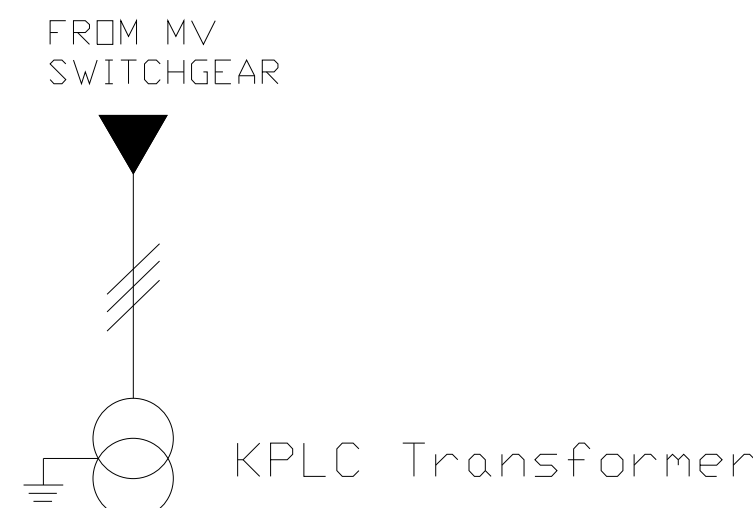

4C 50mm² + 25mm²
XLPE/SWA/PVC CU Cable
40m

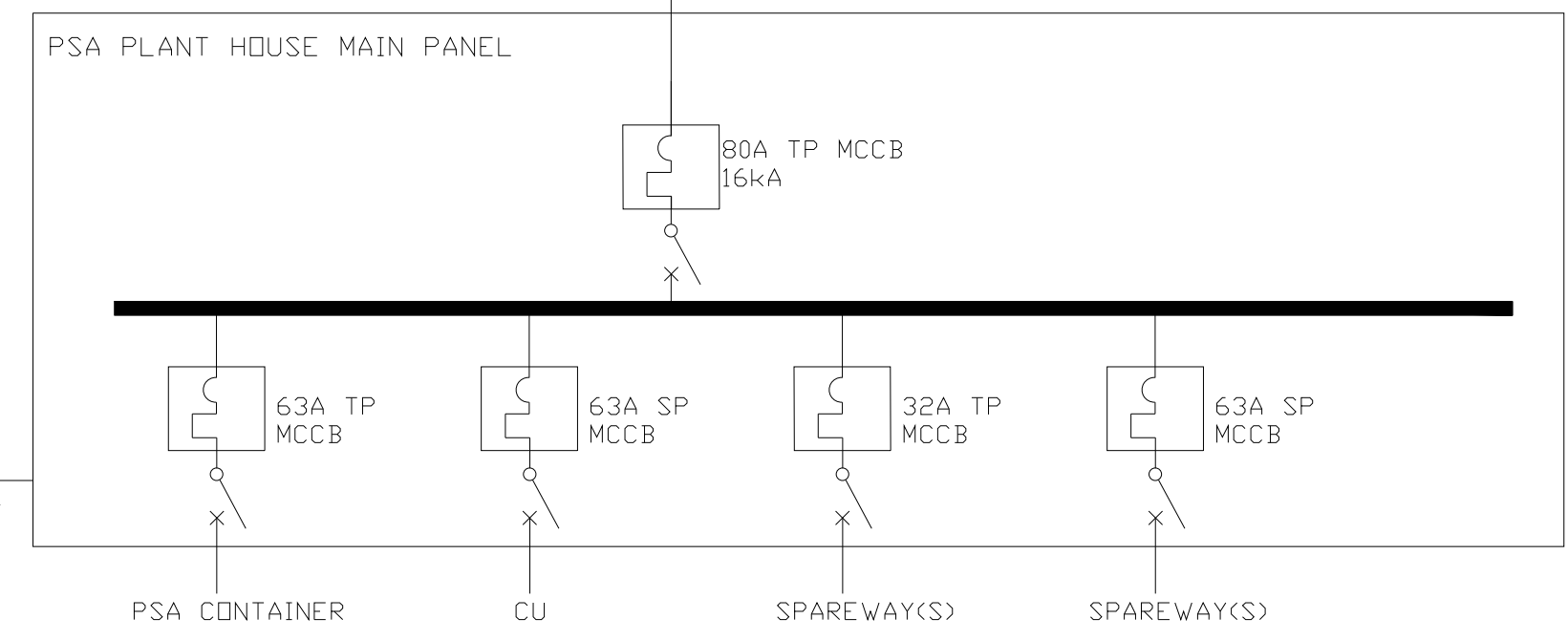

LEGEND:

- Thermal-Magnetic Circuit Breaker
- Residual Current Circuit Breaker
- Earth Electrode
- Surge Diverter
- Mechanically and Electrically Interlocked Automatic Transfer Switch
- Metering
- Transformer
- Generator
- Three-Phase Line or Cable
- Three-Phase Line or Cable, with Neutral and Earth
- Single-Phase Line or Cable
- High Rupturing Capacity (HRC) Fuse
- Utility Scope
- Contractor's Scope
- Existing Scope

NOTES:

1. Coordinate with the Hospital, County Engineers and KPLC to ensure an adequately sized transformer is installed for current and medium term hospital power needs.
2. Coordinate with Hospital and County Engineers to ensure the New Distribution Panel provisions are by and large in accordance with short to medium term Electrical Infrastructure works.
3. Method of cable installation (I) is Armoured Cable buried underground in 600mm Deep trench.
4. Scope of Work Under Blue (section I) is the responsibility of the utility Kenya Power and Lighting Company KPLC. Utility to provide quote and execute any upgrade works where necessary.
5. Scope of Work Under Green (section II) encompass electrical works exclusive of Utility scope.
6. PSA Plant load to primarily comprise a 30kW motor with Star-Delta Starter.
7. Cable lengths are approximate. Exact lengths to be determined on site.

KEY PLAN

The Global Fund

OWNER

Kabartonjo PSA plant

PROJECT

SINGLE LINE DIAGRAM

DRAWING TITLE

SCALE

DATE 5/7/2024

JOB NUMBER

DRAWN

CHECKED

Current Package

E200

DRAWING NUMBER

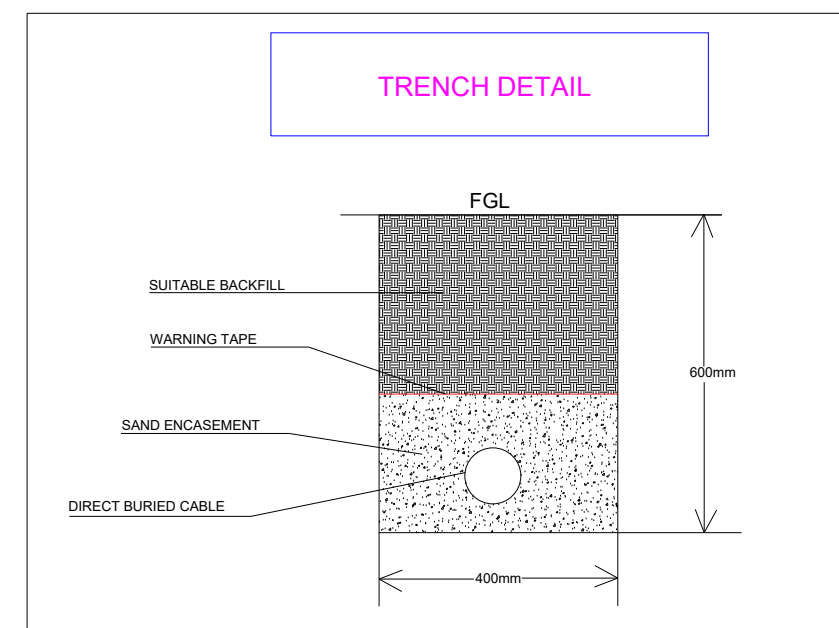

Section II

Section I

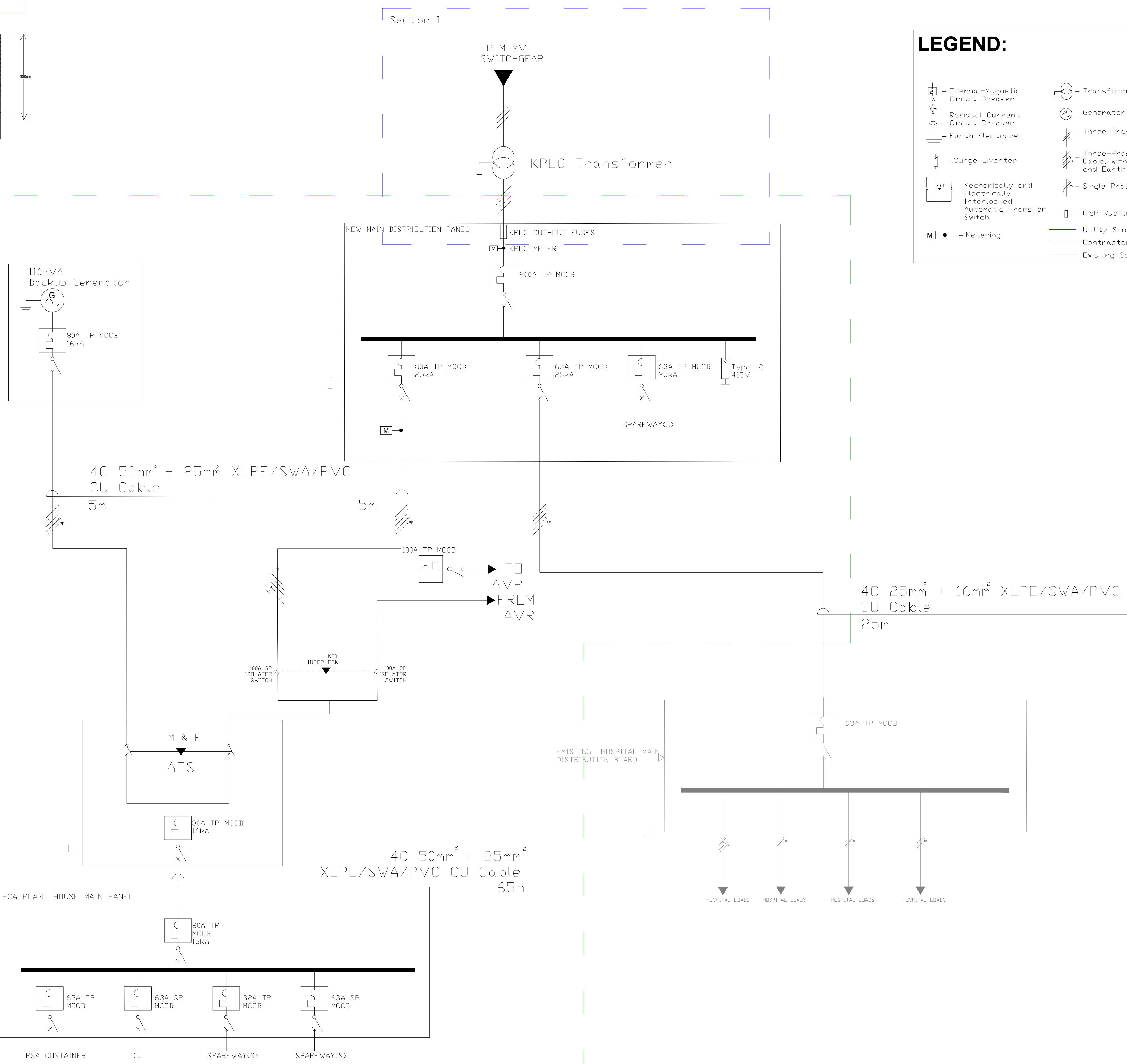

LEGEND:

- Thermal-Magnetic Circuit Breaker
- Residual Current Circuit Breaker
- Earth Electrode
- Surge Diverter
- Mechanically and Electrically Interlocked Automatic Transfer Switch
- Metering
- Transformer
- Generator
- Three-Phase Line or Cable
- Three-Phase Line or Cable, with Neutral and Earth
- Single-Phase Line or Cable
- High Rupturing Capacity (HRC) Fuse
- Utility Scope
- Contractor's Scope
- Existing Scope

- NOTES:**
- Coordinate with the Hospital, County Engineers and KPLC to ensure an adequately sized transformer is installed for current and medium term hospital power needs.
 - Coordinate with Hospital and County Engineers to ensure the New Distribution Panel provisions are by and large in accordance with short to medium term Electrical Infrastructure works.
 - Method of cable installation (I) is Armoured Cable buried underground in 600mm Deep trench.
 - Scope of Work Under Blue (section I) is the responsibility of the utility Kenya Power and Lighting Company KPLC. Utility to provide quote and execute any upgrade works where necessary.
 - Scope of Work Under Green (section II) encompass electrical works exclusive of Utility scope.
 - PSA Plant load to primarily comprise a 30kW motor with Star-Delta Starter.
 - Cable lengths are approximate. Exact lengths to be determined on site.

KEY PLAN

The Global Fund

OWNER

Kacheliba PSA plant

PROJECT

SINGLE LINE DIAGRAM

DRAWING TITLE

SCALE

DATE 5/7/2024

JOB NUMBER

DRAWN

CHECKED

Current Package

E200

DRAWING NUMBER

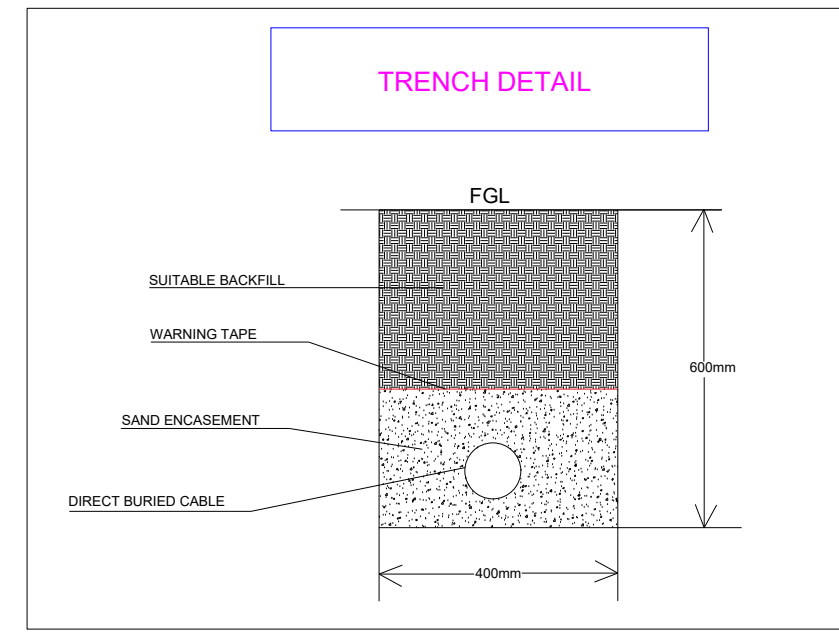

Section II

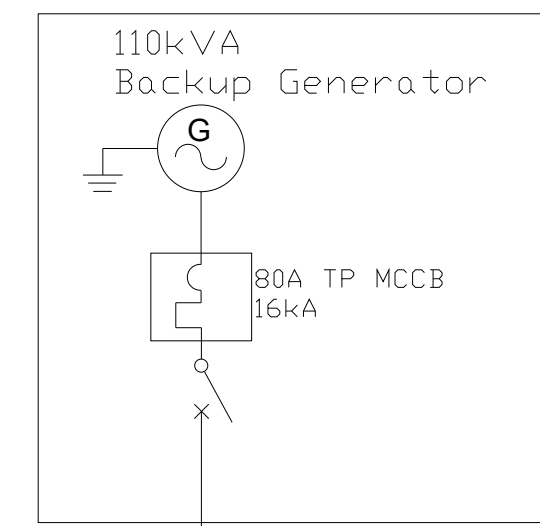

4C 50mm² + 25mm² XLPE/SWA/PVC
CU Cable
6m

Section I

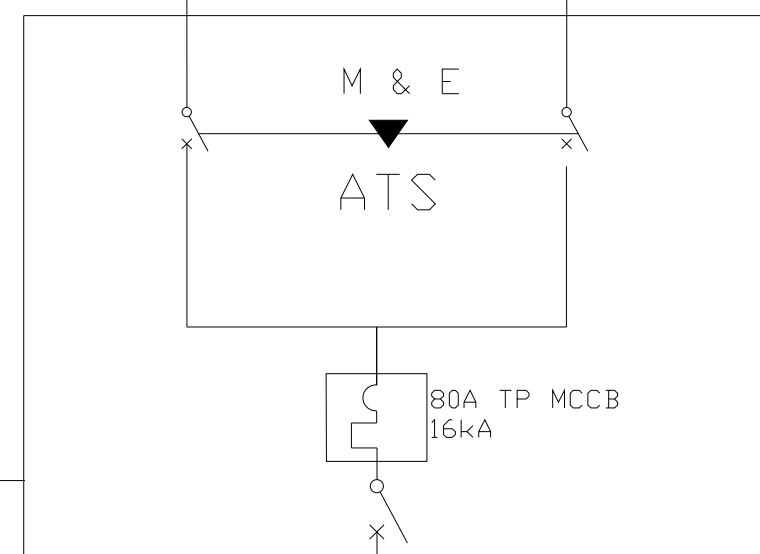
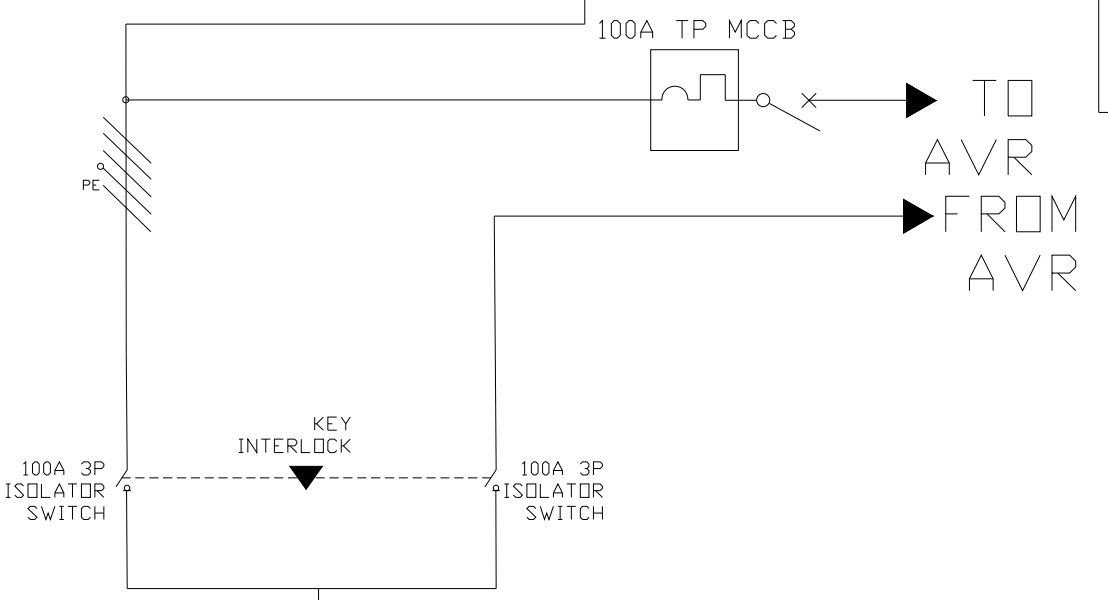
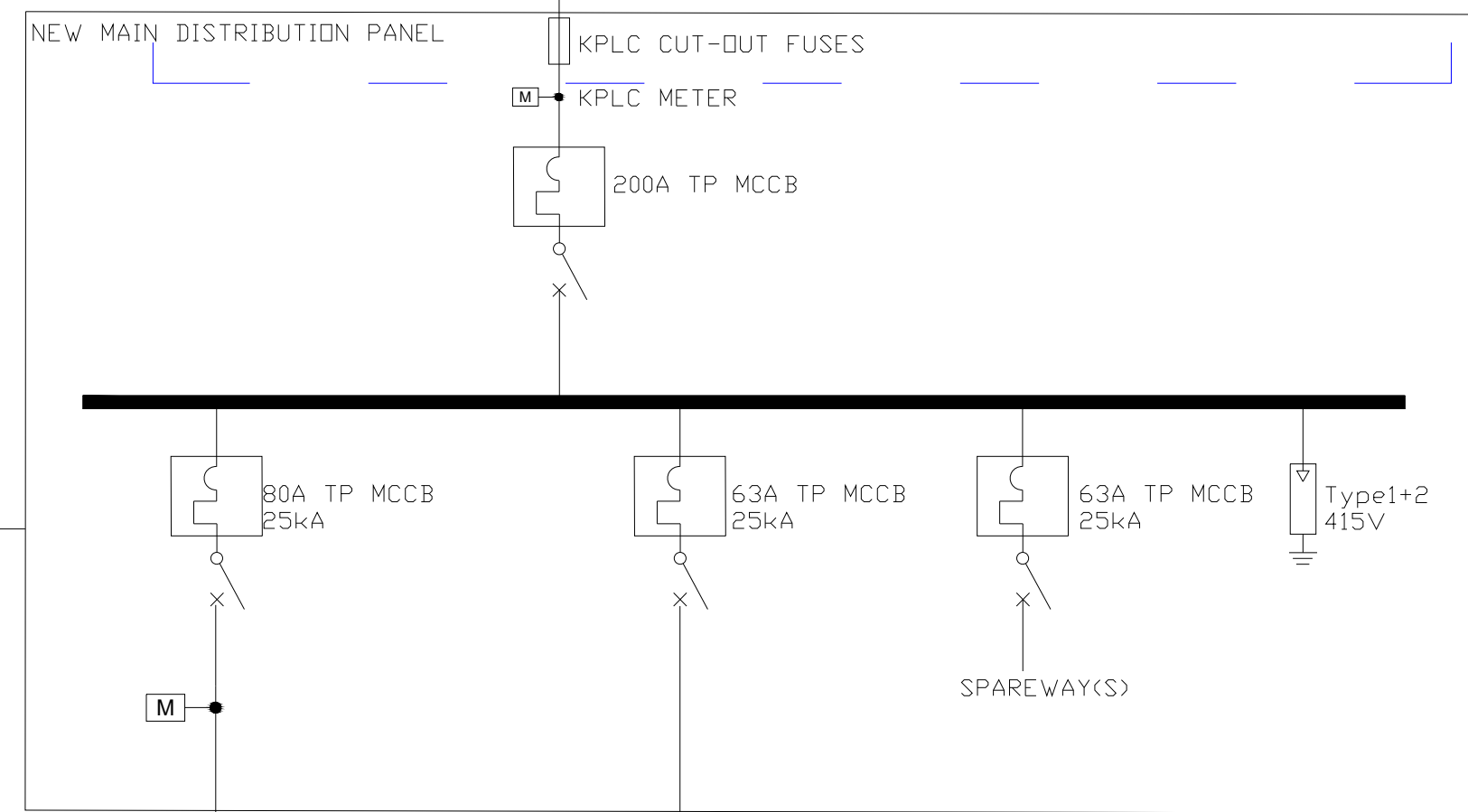
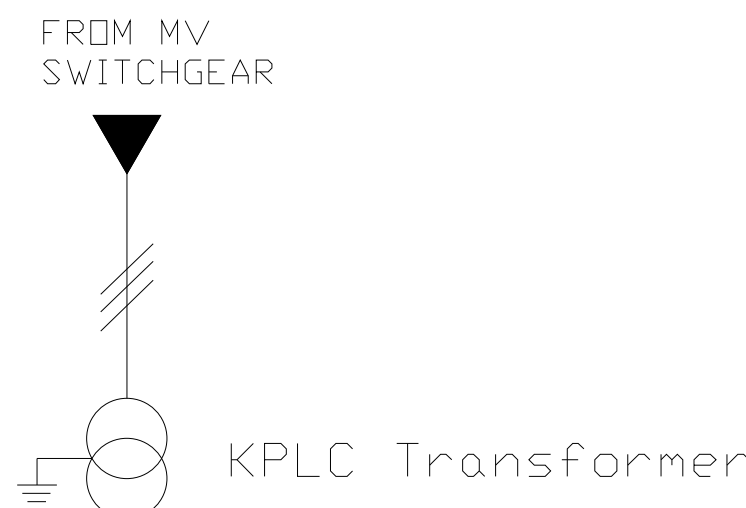

4C 50mm² + 25mm²
XLPE/SWA/PVC CU Cable
30m

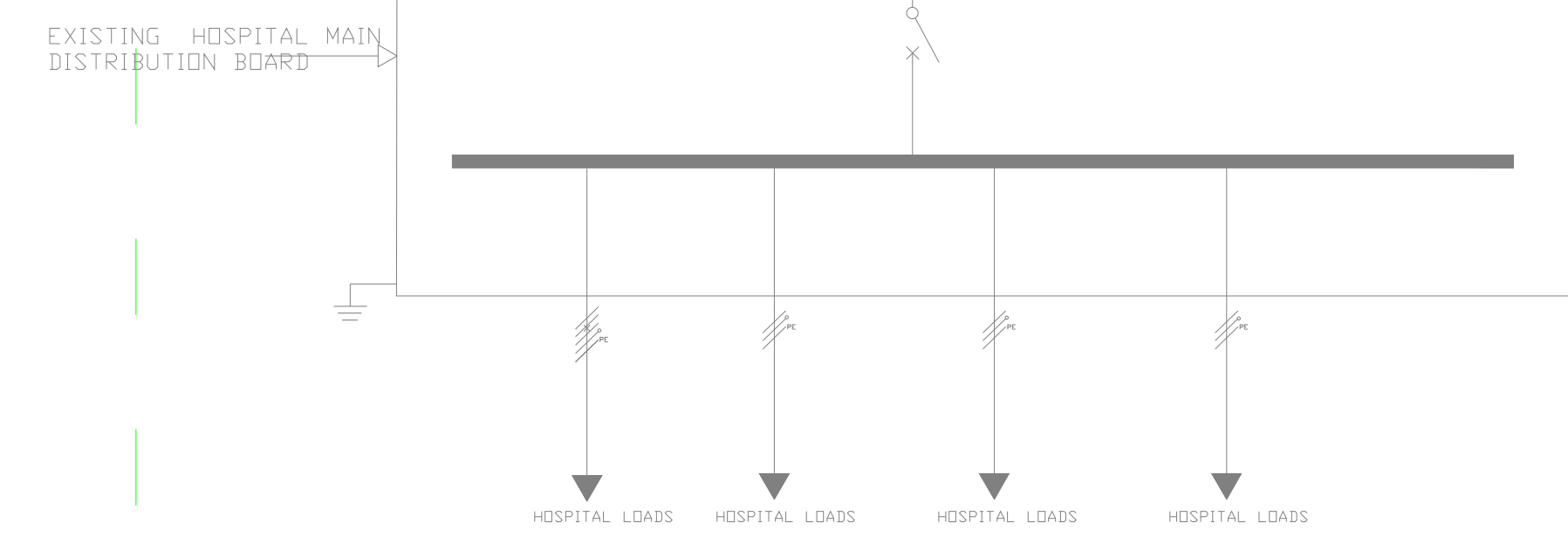
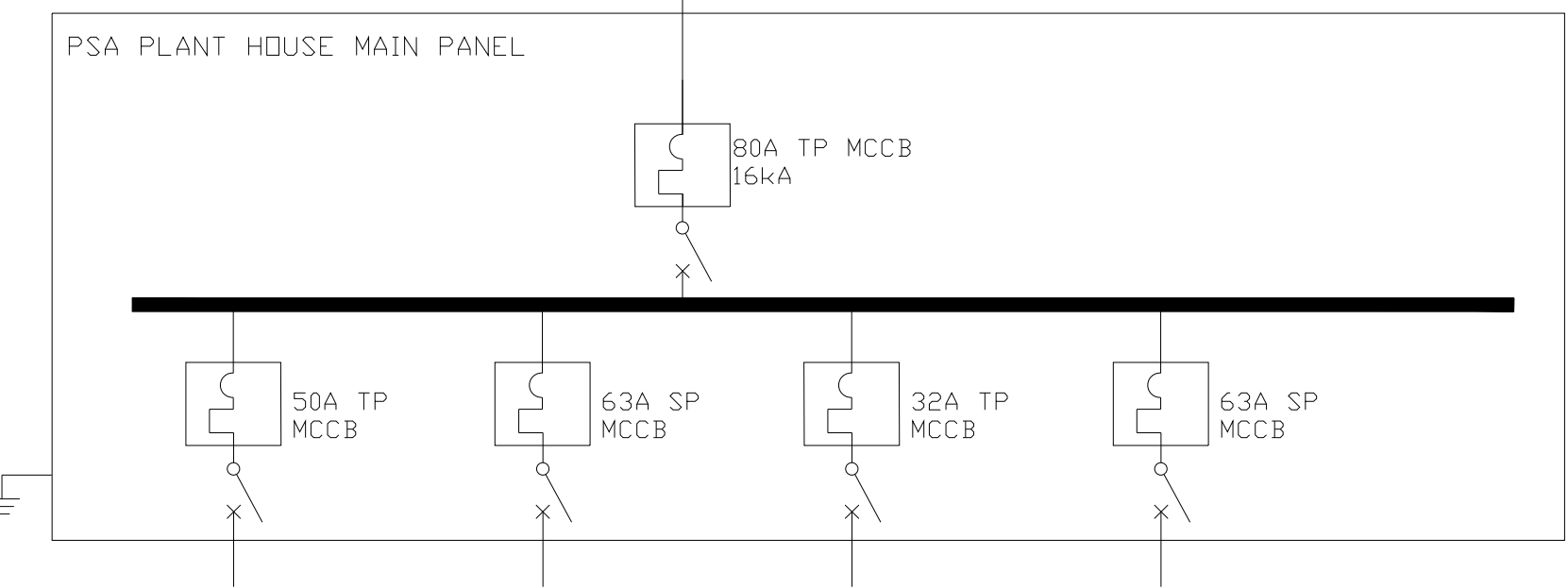

LEGEND:

- Thermal-Magnetic Circuit Breaker
- Residual Current Circuit Breaker
- Earth Electrode
- Surge Diverter
- Mechanically and Electrically Interlocked Automatic Transfer Switch.
- M - Metering
- Transformer
- Generator
- Three-Phase Line or Cable
- Three-Phase Line or Cable, with Neutral and Earth
- Single-Phase Line or Cable
- High Rupturing Capacity (HRC) Fuse
- Utility Scope
- Contractor's Scope
- Existing Scope

NOTES:

- Coordinate with the Hospital, County Engineers and KPLC to ensure an adequately sized transformer is installed for current and medium term hospital power needs.
- Coordinate with Hospital and County Engineers to ensure the New Distribution Panel provisions are by and large in accordance with short to medium term Electrical Infrastructure works.
- Method of cable installation (I) is Armoured Cable buried underground in 600mm Deep trench.
- Scope of Work Under Blue (section I) is the responsibility of the utility Kenya Power and Lighting Company KPLC. Utility to provide quote and execute any upgrade works where necessary.
- Scope of Work Under Green (section II) encompass electrical works exclusive of Utility scope.
- PSA Plant load to primarily comprise a 30kW Air Compressor with Start-Delta Starter.
- Cable lengths are approximate. Exact lengths to be determined on site.

KEY PLAN

The Global Fund

OWNER

Lokitaung PSA plant

PROJECT

SINGLE LINE DIAGRAM

DRAWING TITLE

SCALE

DATE 5/7/2024

JOB NUMBER

DRAWN

CHECKED

Current Package

E200

DRAWING NUMBER

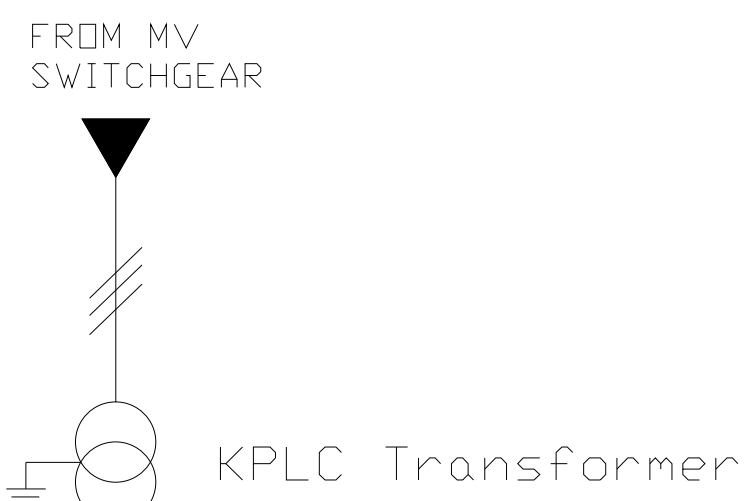
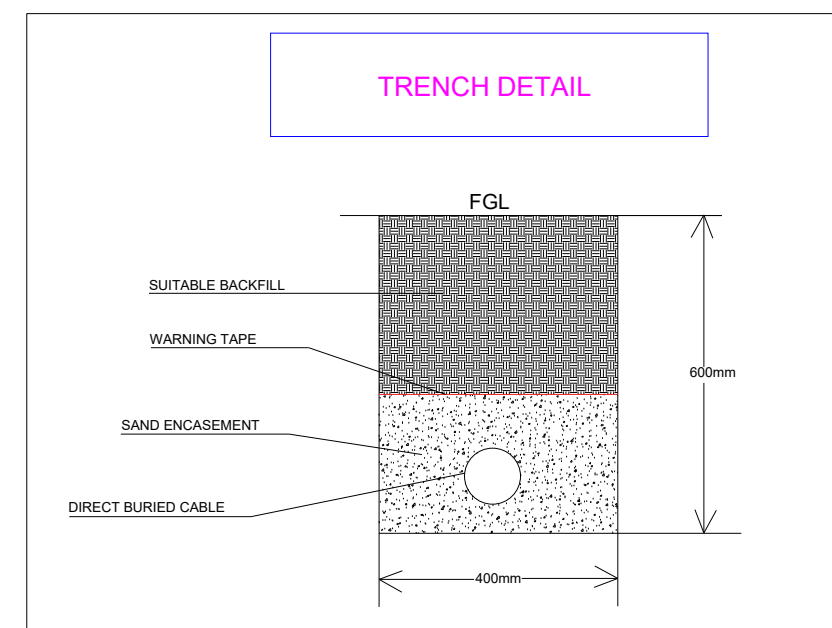

LEGEND:

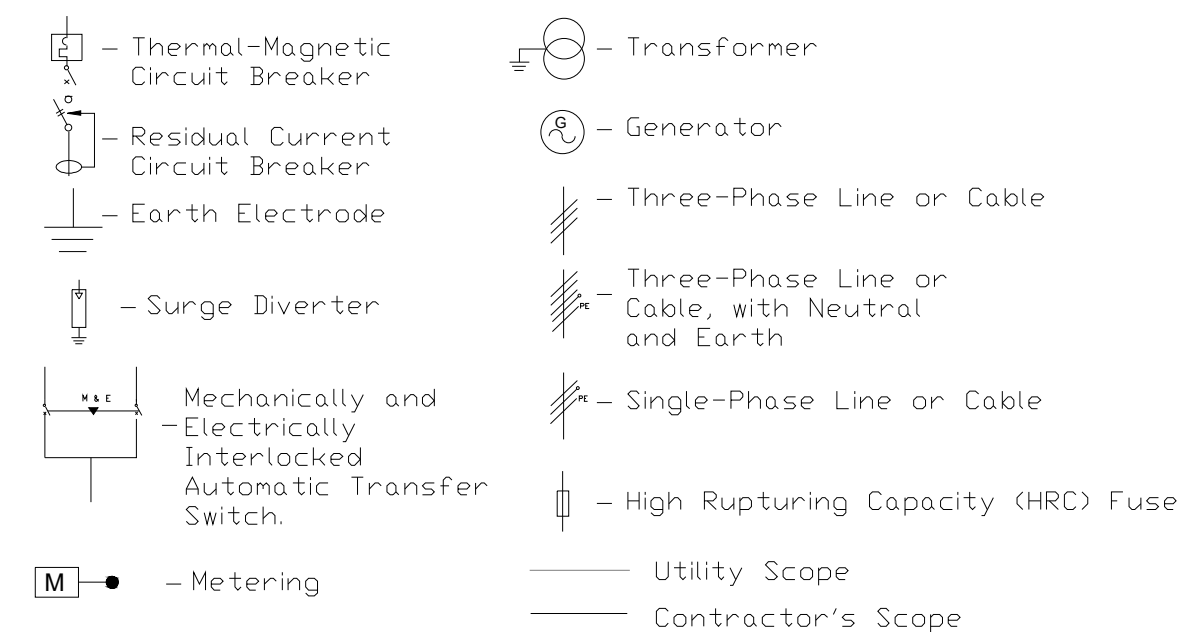

Section II

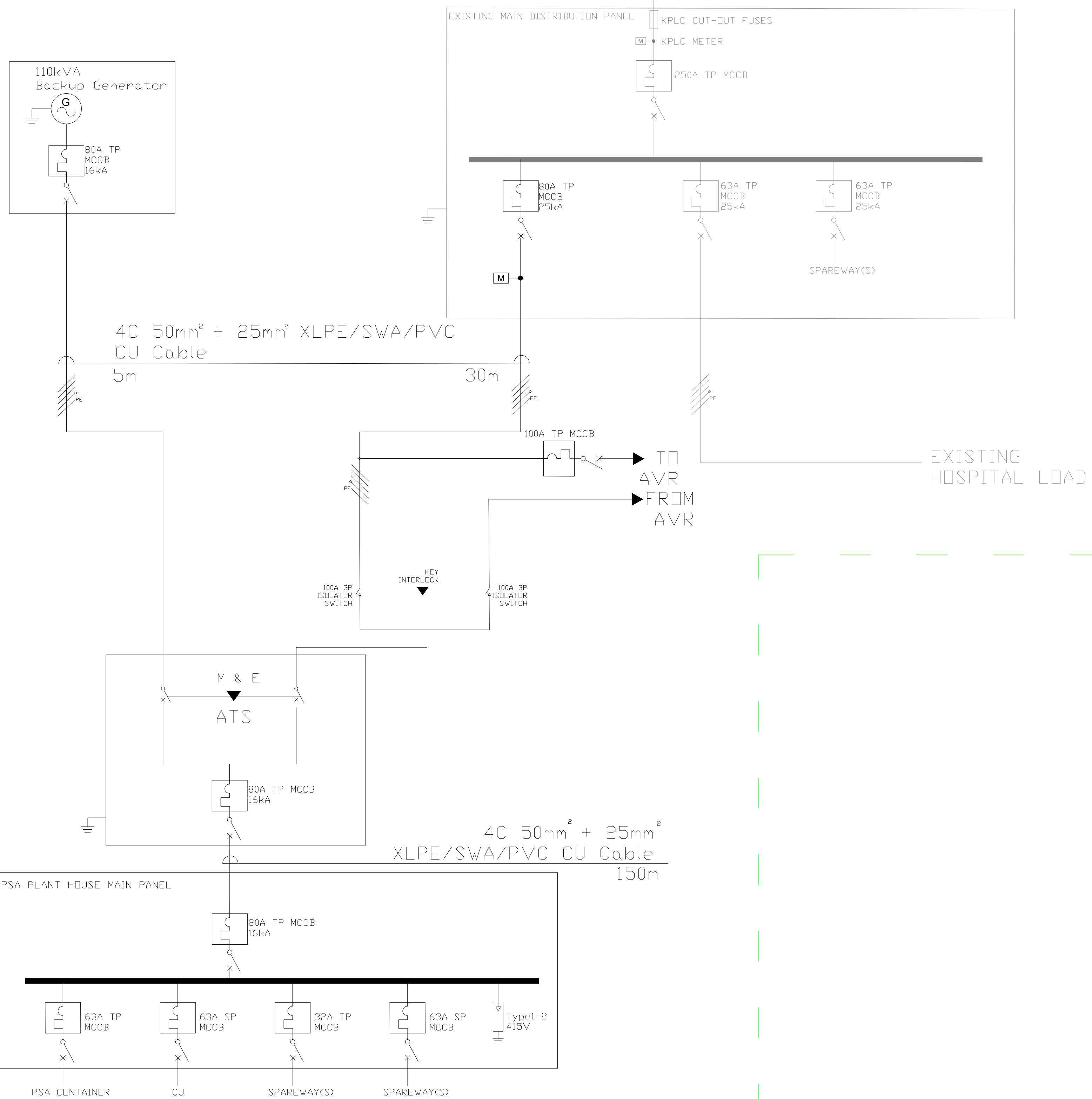

- NOTES:**
- Method of cable installation (1) is Armoured Cable buried underground in 600mm Deep trench.
 - PSA Plant load to primarily comprise a 30kW motor with Star-Delta Starter.
 - Cable lengths are approximate. Exact lengths to be determined on site.

KEY PLAN	
The Global Fund	
OWNER	
Lokori PSA plant	
PROJECT	
SINGLE LINE DIAGRAM	
DRAWING TITLE	
SCALE	DATE 5/7/2024
JOB NUMBER	
DRAWN	CHECKED
Current Package	
E200	
DRAWING NUMBER	